

# Bettis RPE-Series Pneumatic Actuator

Dependable Performance For The Toughest Environments



## Bettis RPE-Series

The RPE-Series is the heavy duty rack & pinion actuator from Bettis. Its rugged industrial design offers a tough “workhorse” range of valve actuators due to a unique set of features.

These features combine to provide a reliable actuator that:

- Improves valve automation to ensure your plant uptime and prevent unplanned downtime
- Makes your installation and maintenance simple and easy due to the standardized customer interfaces
- Allows you to apply the actuator indoors and outdoors, at extreme temperatures, harsh duty and corrosive atmospheres



## The Right Size of Actuator

Spring-return actuator can be equipped with up to 6 different spring sets per actuator size. This allows you to select and configure the most economical actuator size for your application.

## The robust and “work-horse” performance actuator for any harsh environment

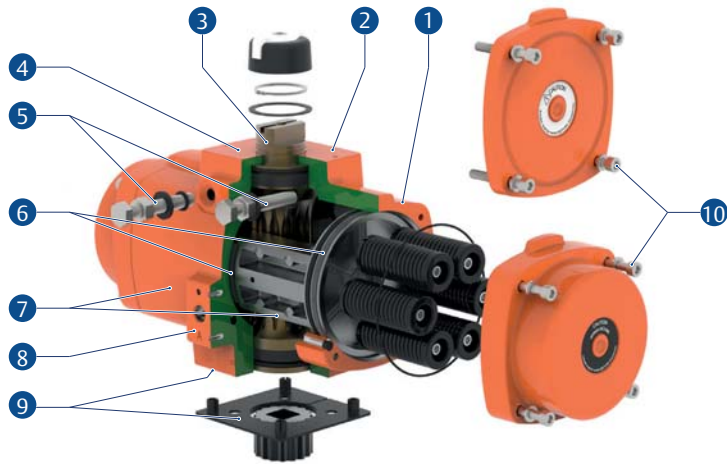

1. Heavy duty body castings provide maximum protection in the harsh environment of process plant locations
2. Polyurethane powder coating provides excellent corrosion resistance on housing and end caps
3. One piece blow-out proof, pressure balanced, pinion allows safe in-field re-configuration from Fail-Close to Fail-Open. The use of aerospace type alloy 7075 T6, provides the best combination of corrosion resistance, high strength and a lightweight construction as well as providing protection against galvanic corrosion
4. VDI/VDE 3845 (NAMUR) top accessory interface
5. Precision dual stroke adjustment provides accurate and intuitive end of stroke adjustment for the Open and Closed valve position
6. Low maintenance bearings for pistons and pinion
7. Accurately designed and machined components assure a perfect fit and long cycle life
8. VDI/VDE 3845 (NAMUR) solenoid interface
9. Dual ISO 5211 mounting patterns allow low-profile direct mounting to valves
10. Stainless steel or Deltatone® coated fasteners

## General Specifications

<b>Torque Range:</b>	<b>Double-Acting</b> 119 to 39498 lbf.in (13.4 to 4449 Nm)	
	<b>Spring-Return</b> 20 to 21188 lbf.in (2 to 2394 Nm; spring end torque)	
<b>Rotation:</b>	Factory set at 90°	
<b>Temperature Range:</b>	-4°F to 175°F (-20°C to 80°C)	
<b>Finish:</b>	<b>Body and end caps:</b> Cast aluminium, anodized and polyurethane powder coated	<b>Pinion:</b> High grade aluminium, hard anodized
	<b>Pistons:</b> Chromated	<b>Fasteners:</b> Stainless steel or Deltatone® coated
<b>Lubrication:</b>	Lubricated for life	
<b>Pressure Range:</b>	2.9 to 120 psig (0.2 to 8.3 barg)	
<b>Pressure Media:</b>	Air, dry or lubricated and inert gases	

## Advanced Design leads to Application Flexibility



### Advanced design techniques

Betts RPE-Series is the result of 40-years of production and design refinement following stringent engineering standards to perform under the toughest, heavy duty applications



**Modular Construction** allows the maximum flexibility across a wide range of applications. In addition, new spring design allow for different air pressures to fit choice of valve

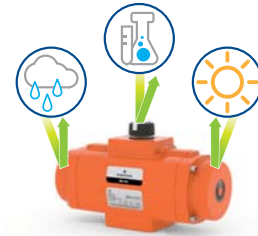

**Maximum corrosion protection** in every Betts RPE is achieved by using anodized body and end cap, stainless steel or Deltatone® coated external steel parts and a polyurethane powder coat. It is tested to pass a 1500 hours salt spray to the ASTM B117 standard to assure a corrosion free long service life

## Ease of Use from Installation to Configuration to Maintenance

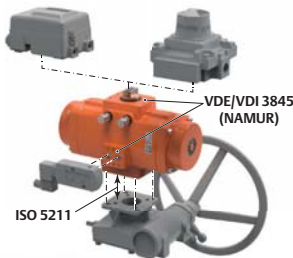

**Compliance to the relevant interface standards** ensures standardization of the valve mounting, solenoid mounting and top mounted switch box or positioner mounting



**Dual Stroke Adjustment** provides precise intuitive end of stroke adjustment for the Open and Closed valve position



### Low Maintenance Bearings

The actuator is lubricated for life. Together with the high performance synthetic bearings, the actuator provides long working life with low maintenance requirements

## Safety, Performance and Global Compliance



**Functional and personal safety** is your plant's number one priority. The spring cartridge design provides maximum personnel safety during maintenance and ensures that "Fail Safe" actuators will always do just that

Quality	ISO9001:2008	✓
Valve Flange	ISO 5211	✓
Solenoid	VDI/VDE3845	✓
Top Accessories	VDI/VDE3845	✓
Explosive Areas	ATEX 2014/34/EU	✓
Pressure Safety	PED 2014/68/EU	✓
Mechanical Safety	MD 2006/42/EC	✓
Hazardous Substances	ROHS 2011/65/EU	✓

Betts RPE pneumatic actuators are manufactured to meet **worldwide quality and safety standards**

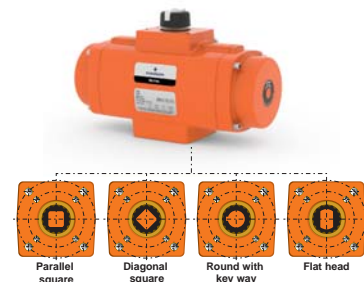

Drive inserts and dual drilling patterns on the valve flange **make direct mounting flexible**, no matter if the valve stem is; square, flat head, or round with key way



Distributed by | Distribuido por :



**ANYTHING**  
**≈ FLOWS ≈**

[INFO@ANYTHINGFLOWS.COM](mailto:INFO@ANYTHINGFLOWS.COM)

[WWW.ANYTHINGFLOWS.COM](http://WWW.ANYTHINGFLOWS.COM)

**Flow Control , our passion ®**

**Life Flows on ™**



**SCAN ME**