

G01 through G10 Spring-Return Pneumatic Actuators with M11 Hydraulic Override



Table of Contents

Section 1: Introduction

1.1	General Service Information	1
1.2	Definitions	1
1.3	General Safety Information	2
1.4	Bettis Reference Materials	2
1.5	Service Support Items	3
1.6	Lubrication and Fluid Requirements.....	3
1.7	General Tool Information	3
1.8	Actuator Storage.....	4
1.9	Actuator Installation	4
1.10	Actuator Start-up	4
1.11	Actuator Operation	5

Section 2: Actuator Disassembly

2.1	General Disassembly	6
2.2	Pneumatic Power Module Disassembly	6
2.3	Drive Module Disassembly	9
2.4	G01 Through G5 M11 Hydraulic Override Cylinder Disassembly	11
2.5	G7 Through G10 M11 Hydraulic Override Cylinder Disassembly	12

Section 3: Actuator Reassembly

3.1	General Reassembly	13
3.2	Drive Module Reassembly	13
3.3	Pneumatic Power Module Reassembly	18
3.4	G2 and G3 Early Model Pneumatic Power Module Reassembly.....	21
3.5	G01 through G5 M11 Hydraulic Override Cylinder Reassembly.....	23
3.6	G7 through G10 M11 Hydraulic Override Cylinder Reassembly.....	24
3.7	Actuator Testing	25

Section 4: Field Conversions

4.1	Fail Mode Reversal (CW to CCW, or CCW to CW)	27
4.2	Converting Double-Acting Actuator To Spring-Return With Override Cylinder Assembly.....	27

Section 5: Module Removal and Installation

5.1	M11 Override Cylinder Removal	28
5.2	M11 Override Cylinder Installation	29
5.3	Spring Module Removal	30
5.4	Spring Module Installation	32
5.5	Pneumatic Power Module Removal	34
5.6	Pneumatic Power Module Installation	35
5.7	Power Swivel Removal	36
5.8	Power Swivel Module Installation	37

Section 6: Actuator Support Information

6.1 M11 Hydraulic Override System Fluid Volume 38
6.2 Module Weights by Item Number and Actuator Housing Size 38
6.3 G01 Tool Style and Wrench Size 39
6.4 G2 Tool Style and Wrench Size..... 40
6.5 G3 Tool Style and Wrench Size..... 40
6.6 G4 Tool Style and Wrench Size..... 41
6.7 G5 Tool Style and Wrench Size..... 41
6.8 G7 Tool Style and Wrench Size..... 42
6.9 G8 Tool Style and Wrench Size..... 42
6.10 G10 Tool Style and Wrench Size 43

Section 7: Troubleshooting

7.1 Fault Insertion 44
7.2 Operational Test..... 45

Section 8: Removal and Decommissioning

8.1 Removal and Decommissioning 46

Section 9: Document Revision47

Appendix A: List of Tables48

Appendix B: List of Drawings49

Section 1: Introduction

1.1 General Service Information

- 1.1.1 This service procedure is offered as a guide to enable general maintenance to be performed on Bettis™ G01XXX-SR, G2XXX SR, G3XXX SR, G4XXX SR, G5XXX SR, G7XXX SR, G8XXX SR, and G10XXX SR Spring-Return Series Single Pneumatic Power Module Actuators with M11 or M11 S Hydraulic Override Module.
- 1.1.2 Normal recommended service interval for this actuator series is five years.

NOTE:

Storage time is counted as part of the service interval.

- 1.1.3 This procedure is applicable with the understanding that all electrical power and pneumatic pressure has been removed from the actuator.
- 1.1.4 Remove all piping and mounted accessories that will interfere with the module(s) that are to be worked on.
- 1.1.5 This procedure should only be implemented by a technically competent technician who should take care to observe good workmanship practices.
- 1.1.6 Numbers in parentheses, () indicate the bubble number (reference number) used on the Bettis assembly drawing and Actuator Parts List.
- 1.1.7 This procedure is written using the stop screw side of the housing (1-10) as a reference and this side will be considered the front side of the actuator. The housing cover (1-20) will be the top of the actuator.
- 1.1.8 Actuator module weights are listed in Section 6 Table 12.
- 1.1.9 When removing seals from seal grooves, use a commercial seal removing tool or a small screwdriver with sharp corners rounded off.
- 1.1.10 Use a non-hardening thread sealant on all pipe threads.

⚠ CAUTION: FOLLOW MANUFACTURER'S INSTRUCTIONS

Apply the thread sealant per the manufacturer's instructions.

- 1.1.11 Bettis recommends that disassembly of the actuator components should be done in a clean area on a workbench.

1.2 Definitions

⚠ WARNING

If not observed, user incurs a high risk of severe damage to actuator and/or fatal injury to personnel.

⚠ CAUTION

If not observed, user may incur damage to actuator and/or injury to personnel.

NOTE:

Advisory and information comments provided to assist maintenance personnel to carry out maintenance procedures.

NOTE:

This product is only intended for use in large-scale fixed installations excluded from the scope of Directive 2011/65/EU on the restriction of the use of certain hazardous substances in electrical and electronic equipment (RoHS 2).

1.3 General Safety Information

Products supplied by Bettis, in its “as shipped” condition, are intrinsically safe if the instructions contained within this Service Instruction are strictly adhered to and executed by well trained, equipped, prepared and competent personnel.

⚠ WARNING: READ WARNING SIGNS

For the protection of personnel working on Bettis actuators, this procedure should be reviewed and implemented for safe disassembly and reassembly. Close attention should be noted to the WARNINGS, CAUTIONS and NOTES contained in this procedure.

⚠ WARNING: FOLLOW PLANT SAFETY PROCEDURES

This procedure should not supersede or replace any customer’s plant safety or work procedures. If a conflict arises between this procedure and the customer’s procedures the differences should be resolved in writing between an authorized customer’s representative and an authorized Bettis representative.

1.4 Bettis Reference Materials

- 1.4.1 Assembly Drawing for G2-SR-M11 through G5-SR-M11 model actuators with one Pneumatic Power Module and one Spring Module with M11 Hydraulic Override Module use part number 121410.
- 1.4.2 Assembly Drawing for G7-SR-M11 through G10-SR-M11 model actuators with one Pneumatic Power Module and one Spring Module with M11 Hydraulic Override Module use part number 121411.
- 1.4.3 M11 Manual Hydraulic Override System operating instructions part number 126858 with M11 Assembly Drawing part number 126567.
- 1.4.4 M11-S Manual Hydraulic Override System operating instructions part number 121960 with M11 S Assembly Drawing part number 121107.

1.5 Service Support Items

- 1.5.1 Bettis module service kits.
- 1.5.2 For rod extension retainer nut tool part number, refer to the following table.

NOTE:

These tools are required only when extension rod assembly (1-50) or (9-50) is removed or when a new extension rod assembly is installed.

Table 1. G-Series Models

Actuator Model	Bettis Part Number	Actuator Model	Bettis Part Number
G01	None required	G5/G7	117369
G2	123616	G8/G10	117368
G3/G4	117370		

- 1.5.3 Commercial leak testing solution.
- 1.5.4 Non-hardening thread sealant.

1.6 Lubrication and Fluid Requirements

NOTE:

Lubricants and Fluids, other than listed in step 1.6.1 and 1.6.2 should not be used without prior written approval of Bettis Product Engineering.

- 1.6.1 All temperature services (-50°F to +350°F)/(-45.5°C to 176.6°C) use Bettis ESL 5 lubricant. ESL 5 lubricant is contained in the Bettis module service kit in tubes or cans and they are marked ESL 4, 5 and 10 lubricant.
- 1.6.2 M11 Manual Hydraulic Override System Fluid Requirements: Standard and high temperature service (-20°F to +350°F) use Dexron II or Shell Tellus T-32 Automatic Transmission Fluid. For low temperature service (-50°F to 150°F) use Univis J13 or HVI 13 Hydraulic Fluid.

1.7 General Tool Information

- 1.7.1 Tools: All tools/Hexagons are American Standard inch. Large adjustable wrench, two (2) large screwdrivers, Allen wrench set, set of open/box end wrenches, rubber or leather mallet, torque wrench (up to 1200 foot pounds / 1627 N-m), breaker bar, small drift punch and a drive socket set. For recommended tool and wrench sizes refer to Section 6, Tables 6.3 through 6.10.

1.8 Actuator Storage

For applications where the actuator is not placed into immediate service, it is recommended that the actuator be cycled with regulated clean/dry pneumatic pressure at least once per month. Indoor storage, if available, is recommended for all actuators. Care should be taken to plug all open ports on actuator and controls to keep out foreign particles and moisture. Actuators should not be stored in an atmosphere that is harmful to resilient seals. Contact factory for extended storage period.

1.9 Actuator Installation

- 1.9.1 Since there are many valve and actuator combinations, it is not practical to include detailed instructions for each type. Mountings are designed to be as simple as possible to keep the guess work out of the installation.
- 1.9.2 Actuators that are shipped from the factory with the travel stops adjusted for approximately ninety degree rotation. Generally, it is necessary to make slight travel stop adjustments once the actuator is installed onto the valve. Refer to the valve manufacturer's recommendations for specific requirements. When the valve has internal stops, the actuator should be adjusted at the same points.

NOTE:

The actual "stopping" should be done by the actuator. If the valve does not have internal stops, adjust the actuator to the full open position. Using this as a reference point, rotate the valve closed and adjust to the valve manufacturer's specifications for total rotation.

- 1.9.3 Good instrument practices are also recommended. Clean/dry regulated pneumatic pressure is essential for long service life and satisfactory operation. It should be noted that new pneumatic lines often have scale and other debris in them and these lines should be purged of all foreign material.

NOTE:

Scale and debris can damage control valves, solenoids, and seals.

1.10 Actuator Start-up

- 1.10.1 Prestart-up checks
 - 1. Inspect to ensure the unit has been mounted onto valve properly. Gear flange mounting bolts, stem key, set screw(s) are installed and secured.
 - 2. No tubing damaged or accessories dislodged during the shipping or the installation.
 - 3. Indicated position confirms valve position.
 - 4. All switching valves in normal operating position as per SCHEMATIC / INSTRUCTIONS

- 1.10.2 Check Connections
 1. Pneumatic / hydraulic components connected as per schematic enclosed or in service manual supplied.
 2. Pneumatic supply connected to the identified ports.
 3. Electrical connection terminals are secured.
 4. Wiring as per enclosed diagram or service manual supplied.
- 1.10.3 When actuator is first placed into service, it should be cycled with regulated pneumatic pressure. This is necessary because the seals have been stationary, causing them to take a "set". Therefore, the actuator should be operated through several cycles to exercise the seals so as to achieve a service ready condition.
- 1.10.4 The actuator speed of operation is determined by a number of factors includes:
 1. Power supply line length
 2. Power supply line size
 3. Power supply line pressure
 4. Control valve and fitting orifice size
 5. Torque requirements of the valve
 6. Size of the actuator
 7. Setting of speed controls
 8. Hydraulic manual override (where available)
- 1.10.5 Due to the interaction of these variables, it is difficult to specify a "normal" operating time. Faster operating time may be obtained by using one or more of the following:
 1. Larger supply lines
 2. Larger control valve
 3. Higher supply pressure *
 4. Quick exhaust valves

— * Not to exceed maximum operating pressure of actuator or control components
- 1.10.6 Slower operating time may be obtained by using flow control valves to meter the exhaust. Excessive exhaust flow metering may cause erratic operation.

1.11 Actuator Operation

- 1.11.1 Controlled Operation: Controlled operation is accomplished by pressurizing and/or depressurizing the appropriate cylinder inlet(s) of a double-acting. Do not exceed pressures indicated on actuator nameplate.
- 1.11.2 Manual Operation: All pressure must be vented or equalized on both sides of the pneumatic piston prior to manual operation.

Section 2: Actuator Disassembly

2.1 General Disassembly

⚠ WARNING: DANGEROUS GAS AND/OR LIQUIDS

It is possible, that the actuator may contain a dangerous gas and/or liquids. Ensure that all proper measures have been taken to prevent exposure or release of these types of contaminants before commencing any work.

- 2.1.1 Section 2 - Actuator Disassembly is written to either completely disassemble the entire actuator or can be used to disassemble individual modules as needed (pneumatic power module or drive module).

⚠ WARNING: DO NOT REMOVE COMPRESSED MODULE

Do not remove spring module while spring is compressed.

- 2.1.2 When the spring module is to be removed it should be removed from the drive module prior to the pneumatic power module removal or disassembly.
- 2.1.3 The pneumatic power module can be disassembled while still attached to the drive module or the pneumatic power module can be removed from the drive module and disassembled separate to the actuator (refer to Section 5 - Module Removal and Installation).
- 2.1.4 To ensure correct reassembly; that is, with pneumatic power module or spring module on same end of drive module as was, mark or tag right (or left) and mark mating surfaces.
- 2.1.5 For spring module removal and installation refer to Section 5 steps 5.3 and 5.4.

NOTE:

Use a means of capturing the hydraulic fluid that will be lost during the removal or disassembly of the override power module. Use a bucket, tub, and large container, etc.

2.2 Pneumatic Power Module Disassembly

NOTE:

Review Section 2 steps 2.1.1 through 2.1.5 General Disassembly before proceeding with Pneumatic Power Module Disassembly.

⚠ WARNING: REMOVE ALL OPERATING PRESSURE

If not already removed disconnect all operating pressure from actuator power cylinders.

⚠ WARNING: SPRINGS IN EXTENDED POSITION

The spring cartridge must be checked to verify that the spring(s) are in their extended position before the pneumatic power module is disassembled from the drive module (refer to Section 5.3 steps 5.3.7 through 5.3.9).

- 2.2.1 Mark and record location of the ports on outer end cap (3-80) and inner end cap (3-10).
- 2.2.2 If actuator is equipped with a power module mounted extended stop (ES) then rotate the ES until clear of the piston rod (3-40).
- 2.2.3 Remove breather assembly (12) from outer end cap (3-80).
- 2.2.4 Refer to assembly drawing sheet 2 Detail "E". Remove two socket cap screws (3-130), with lockwasher (3-140), from outer end cap (3-80).
- 2.2.5 Remove two tie bar hex nuts (3-90) from outboard side of outer end cap (3-80).
- 2.2.6 The fit between cylinder (3-70) and outer end cap (3-80) is very tight. Break end cap free by tapping with a breaker bar on lip provided on the end cap. Remove outer end cap (3-80) from cylinder (3-70).

⚠ CAUTION: DO NOT DAMAGE O-RING GROOVE

Do not damage O-ring groove when removing end cap from cylinder.

NOTE:

When removing cylinder (3-70) off of piston (3-30), tilt the cylinder 15 to 30 degrees with respect to actuator centerline.

- 2.2.7 Remove cylinder (3-70) from inner end cap (3-10).

⚠ CAUTION: DO NOT USE PIPE WRENCH

Do not use pipe wrench to remove tie bars.

- 2.2.8 TIE BAR REMOVAL:

- 2.2.8.1 Remove G01, G2 and G3 tie bars (3-20) as follows:

NOTE:

G01, G2 and G3 models have flats on outboard end of tie bars (3-20) for wrench placement.

- 2.2.8.1.1 Unscrew tie bars (3-20) from inner end cap (3-10). Pull the tie bars out of the inner end cap far enough to expose the O-ring seals (4-80).
- 2.2.8.1.2 Remove O-ring seals (4-80) from the inboard end of tie bars (3-20).
- 2.2.8.1.3 Remove tie bars (3-20) by pulling the tie bars out and through piston (3-30).

2.2.8.2 Remove G4 through G10 tie bars (3-20) as follows:

NOTE:

1. G4 models have flats on outboard end of tie bars (3-20) for wrench placement.
 2. G5 through G10 models have a female square on the out board end of tie bars (3-20) for wrench placement.
-

2.2.8.2.1 Unscrew and remove tie bars (3-20) from inner end cap (3-10) and piston (3-30).

2.2.9 Remove piston as follows: (On early G2 and G3 models equipped with outboard and inboard tie bar nuts skip this step and go to step 2.2.10).

2.2.9.1 Refer to assembly drawing page 2 of 2 Detail "D". Remove two split ring halves (3-50) and one retainer ring (3-60) from outboard side of piston (3-30).

NOTE:

Piston (3-30) acts as the retainer for inboard split ring halves (3-50). When removing the piston be careful to not lose inboard split ring halves (3-50).

2.2.9.2 Remove piston (3-30) and two split ring halves (3-50) from piston rod (3-40).

NOTE:

Steps 2.2.10 is used only on early G2 and G3 models equipped with outboard and inboard tie bar nuts.

2.2.10 Remove early model G2 and G3 pistons as follows:

2.2.10.1 Refer to assembly drawing page 2 of 2 Detail "D". Remove two split ring halves (3-50) and one retainer ring (3-60) from inboard side of piston (3-30).

NOTE:

Piston (3-30) acts as the retainer for outboard split ring halves (3-50).

2.2.10.2 Slide piston (3-30) toward the inner end cap (3-10) until the outboard split ring halves are exposed enough for removal. Remove outboard split ring halves from piston rod (3-40).

2.2.10.3 Remove piston (3-30) and two split ring halves (3-50) from piston rod (3-40).

2.2.11 Remove O-ring seal (4-70) from piston rod (3-40).

2.2.12 Remove hex cap screws (3-100) with lockwashers (3-110) from housing (1-10).

2.2.13 Remove inner end cap (3-10) off of piston rod (3-40).

NOTE:

On early model G2 and G3 actuators remove two hex nuts (3-90) from housing (1-10). These two nuts will be loose after tie bars (3-20) are removed in step 2.2.8.1 and will be located in the area where the piston rod passes through the housing (1-10).

NOTE:

The piston rod (3-40) removal as outlined in step 2.2.14 is only required when the piston rod is being replaced or when the drive module is to be disassembled.

2.2.14 Unscrew and remove piston rod (3-40) from drive module.

2.3 Drive Module Disassembly

NOTE:

Review Section 2 steps 2.1.1 through 2.1.5 General Disassembly before proceeding with Drive Module Disassembly.

- 2.3.1 If not already removed remove piston rod (3-40) from drive module.
 - 2.3.2 Mark stop screws (1-180) left and right. The setting of stop screws (1-180) should be checked and setting recorded before stop screws are loosened or removed.
-

NOTE:

Stop screws will be removed later in this procedure.

NOTE:

For steps 2.3.3 through 2.3.10 refer to assembly drawing sheet 2 Section A-A and Detail "F".

- 2.3.3 Before removing position indicator (1-220), record or mark its position. Remove position indicator (1-220).
-

NOTE:

Step 2.3.4 is used only on G01, G2 and G3 drive modules. Drive modules G4 through G10 will skip step 2.3.4 and continue with step 2.3.5.

- 2.3.4 Remove one vent check assembly (13) from top of housing cover (1-20).
- 2.3.5 Unscrew and remove hex cap screws (1-160) with lockwashers (1-170) from yoke cover (1-150).
- 2.3.6 Remove yoke cover (1-150) from housing cover (1-20).
- 2.3.7 Mark and record the orientation of the position indicator assembly (1-140) in relation to the top of yoke (1-70).
- 2.3.8 Remove position indicator assembly (1-140) from top of yoke (1-70).

- 2.3.9 Remove spring pin (1-100) from top of yoke (1-70).
- 2.3.10 Remove hex cap screws (1-110), with lockwashers (1-115) from housing cover (1-20).

NOTE:

Steps 2.3.11 and 2.3.12 are used only on G7, G8 and G10 drive modules. Drive modules G01, G2, G3, G4 and G5 will skip steps 2.3.11 and 2.3.12 and continue with step 2.3.13.

- 2.3.11 Remove hex cap screws (1-120), with lockwashers (1-115), from housing cover (1-20).
- 2.3.12 Using hex cap screws (1-110), install into holes vacated by hex cap screws (1-120). Use these hex cap screws to jack the housing cover up for removal. Alternately, rotate the hex cap screws clockwise until housing cover (1-20) is clear of housing (1-10).

NOTE:

G01, G2, G3 and G4 model housing cover will have cast tabs for placing prying tools to aid in cover removal.

- 2.3.13 Remove housing cover (1-20) from housing (1-10).

NOTE:

Groove pins (1-130) will remain in housing cover (1-20) when housing cover is removed from housing (1-10). Groove pins (1-130) should not be removed from housing cover (1-20) unless they are damaged and require new replacements.

- 2.3.14 Refer to assembly drawing page 2 of 2 Detail "B". Remove guide bar (1-90) from housing (1-10).
- 2.3.15 Remove top yoke pin thrust bearing (2-10) from top of yoke pin (1-80).
- 2.3.16 Rotate the arms of yoke (1-70) to the center position of housing (1-10).
- 2.3.17 Remove yoke (1-70) with yoke pin (1-80), guide block (1-30), two yoke/guide block bushings (2-30) by lifting yoke up and out of the housing (1-10).
- 2.3.18 Remove bottom yoke pin thrust bearing (2-10) from inside bottom of housing (1-10).
- 2.3.19 Remove yoke pin (1-80) by inserting 3/8"-16 UNC screw into top of the yoke pin and pull straight up and out.
- 2.3.20 Remove guide block (1-30) from between the arms of yoke (1-70).
- 2.3.21 Remove yoke/guide block bushing (2-30) from the top of guide block (1-30).
- 2.3.22 Remove yoke/guide block bushing (2-30) from the top of the lower yoke arm of yoke (1-70).

NOTE:

G01 model actuators skip steps 2.3.23 through 2.3.25 and continue disassembly at step 2.3.26.

- 2.3.23 Refer to assembly drawing page 2 of 2 Detail "B". Use Bettis tool part numbers 117368 (G8/G10), 117369 (G5/G7), 117370 (G3/G4) or 123616 (G2) and remove retention retainer nut assemblies (1-60) and (9-60) from guide block (1-30).
- 2.3.24 Remove rod extension assemblies (1-50) and (9-50) from guide block (1-30).

NOTE:

Spherical washers (1-40) and (9-40) will be removed from guide block (1-30) when the extension rod assemblies are removed.

- 2.3.25 Remove the remaining spherical washers (1-40) and (9-40) from guide block (1-30).
- 2.3.26 Unscrew and remove two stop screw nuts (1-190) from stop screws (1-180).
- 2.3.27 Unscrew and remove two stop screws (1-180) from front of housing (1-10).
- 2.3.28 Housing (1-10) vent check assembly removal as follows:
 - 2.3.28.1 G01, G2 and G3 housing (1-10) unscrew and remove one vent check assembly (13) from the front of housing (1-10).
 - 2.3.28.2 G4 through G10 housing (1-10) unscrew and remove two vent check assemblies (13) from the front of housing (1-10).
- 2.3.29 The following items do not need to be removed from their assembled locations unless being replaced by new items: Two guide bar bearings, two yoke bearings (2-40), yoke pin bearing, yoke pin thrust bearing (2-10) and spring pin (1-100).

2.4 G01 Through G5 M11 Hydraulic Override Cylinder Disassembly

NOTE:

For M11 hydraulic override cylinder removal from spring cartridge refer to Section 5 step 5.1.

- 2.4.1 Unscrew hydraulic ram cover (7-10) from hydraulic override end cap (7-70).
- 2.4.2 Remove hydraulic ram (7-20) from hydraulic ram cover (7-10).

2.5 G7 Through G10 M11 Hydraulic Override Cylinder Disassembly

NOTE:

For M11 hydraulic override cylinder removal from spring cartridge refer to Section 5 step 5.1.

- 2.5.1 Unscrew and remove hex cap screws (7-80) with lockwashers (7-90) from outer end cap (7-70).
- 2.5.2 Remove outer end cap (7-70) from hydraulic cylinder assembly (7-10).
- 2.5.3 Remove piston rod (7-20) from hydraulic cylinder assembly (7-10).
- 2.5.4 Refer to assembly drawing sheet 1 Detail "G". Remove two split ring halves (7-30) and one retainer ring (7-40) from one side of piston (7-50).
- 2.5.5 Refer to assembly drawing sheet 1 Detail "G". Remove two split ring halves (7-30) and one retainer ring (7-40) from the other side of piston (7-50).
- 2.5.6 Remove piston (7-50) from piston rod (7-20).
- 2.5.7 Remove vent tube (7-60) from the hydraulic cylinder assembly.
- 2.5.8 Pipe plug (7-110) does not require removal for routine service.
- 2.5.9 Pipe plug (7-120) does not require removal for routine service.

Section 3: Actuator Reassembly

3.1 General Reassembly

⚠ CAUTION: CHECK SHELF LIFE OF SEALS

Only new seals, which are still within the seal's expectant shelf life, should be installed into the actuator being refurbished.

- 3.1.1 Remove and discard all old seals and gaskets.
- 3.1.2 All parts should be cleaned to remove all dirt and other foreign material prior to inspection.
- 3.1.3 All parts should be thoroughly inspected for excessive wear, stress cracking, galling and pitting. Attention should be directed to threads, sealing surfaces and areas that will be subjected to sliding or rotating motion. Sealing surfaces of the cylinder, tie bars and piston rod must be free of deep scratches, pitting, corrosion and blistering or flaking coating.

⚠ CAUTION: INSPECT PARTS BEFORE USE

Actuator parts that reflect any of the above listed characteristics should be replaced with new parts.

- 3.1.4 Before installation coat all moving parts with a complete film of lubricant. Coat all seals with a complete film of lubricant, before installing into seal grooves.

NOTE:

The parts and seals used in the actuator will be assembled using lubricant as identified in Section 1 step 1.6.1.

- 3.1.5 For spring module installation refer to Section 5 step 5.4.

3.2 Drive Module Reassembly

NOTE:

Review section 3.1 General Reassembly before proceeding with Drive Module Reassembly.

NOTE:

Refer to assembly drawing page 2 of 2 Detail "B" for section drawing of guide block.

- 3.2.1 If guide bar bearings are being replaced install new bearings into guide block (1-30).

NOTE:

The guide bar bearing must be press fit into guide block guide bar bore with the seam located 45 ± 5 degrees of the top or bottom centerline as shown in section A-A.

NOTE:

G01 model actuators skip steps 3.2.2 through 3.2.13 and continue reassembly at step 3.2.14.

3.2.2 Lubricate guide block (1-30), two spherical washers (1-40), and one extension rod assembly (1-50).

3.2.3 Install one spherical washer (1-40) into the side of guide block (1-30).

NOTE:

The spherical side of washer (1-40) will be facing to the outside of guide block (1-30).

3.2.4 Install second spherical washer (1-40) over threaded end of extension rod assembly (1-50).

NOTE:

The spherical side of the washer will go on the extension rod assembly facing the head of the extension rod assembly.

3.2.5 Install extension rod assembly (1-50) into guide block (1-30) and up against the first spherical washer (1-40).

3.2.6 Install extension retainer nut (1-60) over extension rod assembly (1-50) and screw into guide block (1-30).

3.2.7 Tighten extension retainer nut assembly (1-60) until extension rod assembly (1-50) cannot move. Back off the extension retainer nut assembly (1-60) just enough to allow for extension rod assembly (1-50) to move freely.

NOTE:

Steps 3.2.8 through 3.2.13 are to be completed when the actuator is equipped with a spring module. If the actuator is double-acting then skip steps 3.2.8 through 3.2.13 and continue actuator reassembly starting with step 3.2.14.

3.2.8 Lubricate guide block (1-30), two spherical washers (9-40) and one extension rod assembly (9-50).

3.2.9 Install one spherical washer (9-40) into the side of guide block (1-30).

NOTE:

The spherical side of washer (9-40) will be facing to the outside of guide block (1-30).

3.2.10 Install second spherical washer (9-40) over threaded end of extension rod assembly (9-50).

NOTE:

The spherical side of the washer will go on the extension rod assembly facing the head of the extension rod assembly.

- 3.2.11 Install extension rod assembly (9-50) into guide block (1-30) and up against the first spherical washer (9-40).
 - 3.2.12 Install extension retainer nut (9-60) over extension rod assembly (9-50) and screw into guide block (1-30).
 - 3.2.13 Tighten extension retainer nut assembly (9-60) until extension rod assembly (9-50) cannot move. Back off the extension retainer nut assembly (9-60) just enough to allow for extension rod assembly (9-50) to move freely.
-

NOTE:

Consult Houston, Texas Bettis Service Coordinator for "yoke bearing, yoke pin bearing or yoke/guide block bushing installation information".

- 3.2.14 If the two yoke bearings (2-40) are being replaced, install new bearing into housing cover (1-20) and housing (1-10).
-

NOTE:

The yoke bearing (2-40) must be press fit into housing (1-10) and housing cover (1-20). Install the yoke bearings with the bearing seam located 45 ± 5 degrees from the yoke arm slot when yoke (1-70) is rotated to its full clockwise position.

- 3.2.15 If the two yoke pin thrust bearings (2-10) are being replaced install new bearing into housing cover (1-20) and housing (1-10).
 - 3.2.16 Lubricate two yoke/guide block bushings (2-30) and install onto top and bottom sides of guide block (1-30).
-

NOTE:

The guide block (1-30) should be already pre-assembled with extension rod assembly and associated parts assembled in the guide block.

- 3.2.17 Install guide block (1-30), with yoke/guide block bushings (2-30), between arms of yoke (1-70).
- 3.2.18 Install O-ring seal (2-50) into inner diameter O-ring groove in the bottom of housing (1-10).
- 3.2.19 Coat the bearing surfaces of the yoke (1-70) with lubricant and install into housing (1-10).
- 3.2.20 Align hole in guide block (1-30) with the matching holes in the two yoke/guide block bushings (2-30) and the slots in the arms of yoke (1-70).

NOTE:

The yoke pin can be held in place by installing a screw into the .375-16UNC tapped hole in the upper end of yoke pin (1-80).

- 3.2.21 Install yoke pin (1-80) by inserting into the upper yoke arm, upper yoke/guide block bushing, guide block, lower yoke/guide block bushing, lower yoke arm and resting on lower yoke pin thrust bearing (2-10).
 - 3.2.22 Install guide bar (1-90) into either side of housing (1-10) by inserting through the housing, through guide block and then insert the guide bar into the other side of housing (1-10).
 - 3.2.23 Refer to assembly drawing page 2 of 2 Section A-A. Install spring pin (1-100) into the top of yoke (1-70).
 - 3.2.24 Install position indicator assembly (1-140) onto the top of yoke (1-70) and over spring pin (1-100).
-

NOTE:

Refer to Section 2 step 2.3.7 for correct installation position.

- 3.2.25 Install O-ring (2-50) into housing cover (1-20).
 - 3.2.26 Install housing cover O-ring (2-60) into housing cover (1-20).
 - 3.2.27 Install the housing cover (1-20), being careful not to damage O-ring seals (2-50) and (2-60).
 - 3.2.28 Place lockwashers (1-115) onto hex cap screws (1-110).
-

NOTE:

On G7 through G10 model actuators apply thread adhesive, Loctite 242, to threads of hex cap screws (1-110). Reference assembly drawing note number 9.

- 3.2.29 Install hex cap screws (1-110) with lockwashers (1-115) through housing cover (1-20) and into housing (1-10).
-

NOTE:

Leave hex cap screws (1-110) finger tight - do not tighten.

- 3.2.30 **NOTE:** Do this step only if groove pins (1-130) have been pulled or if the pins are being replaced. Drive groove pins (1-130) through housing cover (1-20) and into housing (1-10). The groove pins should be flush with the cover.

- 3.2.31 Torque tighten hex cap screws (1-110) until a final lubricated torque, as listed in Table 2, has been achieved.

Table 2. Housing Cover Screw Quantity and Torque

Model	Qty	TORQUE ($\pm 5\%$)		Model	Qty	TORQUE ($\pm 5\%$)	
		Lbf-ft.	N-m			Lbf-ft.	N-m
G01	4	40	54	G5	8	100	136
G2	6	40	54	G7	8	100	136
G3	8	40	54	G8	12	100	136
G4	8	40	54	G10	16	100	136

NOTE:

Complete step 3.2.32 on G5, through G10 model actuators. For G01 through G4 model actuators skip step 3.2.32 and proceed to step 3.2.33.

- 3.2.32 On G5 through G10 models;
3.2.32.1 Place lockwashers (1-115) onto hex cap screws (1-120).

NOTE:

Hex cap screws (1-120) are only used as "hole" fillers and to protect threads from environment.

- 3.2.32.2 Install and tighten hex cap screws (1-120) with lockwashers (1-115).
3.2.33 Install thrust bearing (2-110) onto position indicator (1-140).
3.2.34 Install O-ring seal (2-100) onto position indicator (1-140).
3.2.35 Install upper bearing (2-120) into yoke cover (1-150).
3.2.36 Install rod wiper (2-80) into yoke cover (1-150).
3.2.37 Install O-ring seal (2-70) into yoke cover (1-150).
3.2.38 Install yoke cover (1-150) onto housing cover (1-20) and over position indicator assembly (1-140).

NOTE:

During yoke cover installation be careful not to damage O-ring seal (2-70) and rod wiper (2-80).

- 3.2.39 Place lockwashers (1-170) onto hex cap screws (1-160).
3.2.40 Install and tighten hex cap screws (1-160) with lockwashers through yoke cover (1-150) and into housing cover (1-20).
3.2.41 Vent check assembly installation as follows:
3.2.41.1 G01, G2 and G3 housing (1-10) using pipe sealant install one vent check assembly (13) into the front of housing (1-10).
3.2.41.2 G2 and G3 housing (1-10) using pipe sealant install one vent check assembly (13) into the top area of housing cover (1-20).

- 3.2.41.3 G4 through G10 housing (1-10) using pipe sealant install two vent check assemblies (13) into the front of housing (1-10).
- 3.2.42 NOTE: Refer to Section 2 step 2.3.3 for correct position indicator placement. Install position indicator (1-220) over the exposed shaft of position indicator assembly (1-140).
- 3.2.43 Install stop screw nuts (1-190) onto stop screws (1-180).
- 3.2.44 Install O-ring (2-90) onto stop screws (1-180).
- 3.2.45 Install two stop screws (1-180) into two stop screw holes on the front of housing (1-10).
- 3.2.46 Adjust both stop screws (1-180) back to settings recorded earlier in Section 2 at step 2.3.2.
- 3.2.47 Tighten both stop screw nuts (1-190) securely.

3.3 Pneumatic Power Module Reassembly

NOTES:

1. For early model G2 and G3 actuators with double nuts on the power module use section 3.4 for reassembly.
2. Refer to Section 2 step 2.1.4 for the correct installation location for piston rod (3-40).
3. THE ACTUATOR MUST BE IN THE APPROPRIATE OVERTRAVEL POSITION. Confirm over travel position by observing the guide block (1-30) is against the inner wall of housing (1-10).

- 3.3.1 Lubricate piston rod (3-40) and insert through the side of housing (1-10).
 - 3.3.1.1 G2 thru G10 screw piston rod (3-40) onto extension rod assembly (1-50).
 - 3.3.1.2 G01 only screw piston rod (3-40) onto guide block (1-30).
- 3.3.2 Torque tighten piston rod (3-40) to the lubricated torque as listed in Table 3.

Table 3. Piston Rod Torque Information

Housing Model	TORQUE (±5%)		Housing Model	TORQUE (±5%)	
	Lbf-ft.	N-m		Lbf-ft.	N-m
G01	90	122	G5	240	325
G2	90	122	G7	240	325
G3	90	122	G8	240	325
G4	240	325	G10	240	325

- 3.3.3 Refer to assembly drawing page 2 of 2 Detail "C". Install one rod wiper (4-10) into inner end cap (3-10).
- 3.3.4 Install one rod bushing (4-20) into inner end cap (3-10).
- 3.3.5 Coat one Polypak seal (4-30) with lubricant and install, lip first, into inner end cap (3-10).

⚠ CAUTION: POLYPAK SEAL FACING PISTON SIDE

Install the Polypak seal with energizer ring facing piston side of inner end cap (3-10).

- 3.3.6 Install one O-ring seal (4-90) into seal groove located on the inboard face of inner end cap (3-10).
- 3.3.7 Install inner end cap (3-10) on to housing (1-10).

NOTE:

The pressure inlet port should be positioned in the same position as recorded in section 2.2 step 2.2.1.

- 3.3.8 Place lockwashers (3-110) onto hex cap screws (3-100).
- 3.3.9 Install hex cap screws (3-100), with lockwashers, through housing (1-10) and into inner end cap (3-10).
- 3.3.10 Refer to assembly drawing page 2 of 2 Detail "D". Install one O-ring seal (4-70) into the seal groove in piston rod (3-40).
- 3.3.11 Apply lubricant to two sets of rod T-seal components (4-50).

NOTE:

The T-seal is composed of one rubber seal and two split skive-cut back-up rings.

- 3.3.11.1 Install two sets of rod T-seals (4-50) into the internal diameter seal grooves of piston (3-30).
- 3.3.11.2 Install a back-up ring on each side of the T-seal.
- 3.3.11.3 When installing the back-up rings, do not align the skive-cuts.
- 3.3.11.4 If the back-up rings are too long and the rings overlap beyond the skive-cuts, then the rings must be trimmed with a razor sharp instrument.
- 3.3.12 Install two split ring halves (3-50) into the inner most groove in piston rod (3-40) and retain by installing the recessed area of piston (3-30) onto the piston rod and over the two split ring halves (3-50).
- 3.3.13 Install two split ring halves (3-50) into the piston rod, in front of the piston installed in the previous step, and retain with retainer ring (3-60).
- 3.3.14 Install one O-ring seal (4-40) onto the outer diameter seal groove of inner end cap (3-10).
- 3.3.15 Coat one D-ring seal (4-60) with lubricant and install into the piston external seal groove.

NOTE:

The flat side of the D-ring seal goes down into the seal groove.

- 3.3.16 Coat two tie bars (3-20) with lubricant and install by carefully pushing tie bars through piston (3-30) and rod T-seal (4-50).
- 3.3.17 Screw tie bars (3-20) into inner end cap (3-10) and tighten until the threads bottom out.
- 3.3.18 Refer to assembly drawing page 2 of 2 Detail "E". Coat two O-ring seals (4-80) with lubricant and install into outer end cap (3-80).

- 3.3.19 Apply lubricant to one O-ring seal (4-40) and install into the outer diameter O-ring groove of outer end cap (3-80).
- 3.3.20 Apply lubricant to the bore of cylinder (3-70).
- 3.3.21 Install lubricated cylinder (3-70) over piston (3-30) and onto inner end cap (3-10). When installing the cylinder over the piston seal tilt cylinder 15 to 30 degrees to piston rod.

⚠ CAUTION: CAREFULLY INSTALL CYLINDER

If needed, when installing the cylinder, hammer on the end of the cylinder only with a non-metallic object.

- 3.3.22 Install outer end cap (3-80) over tie bars (3-20) and into cylinder (3-70).

NOTE:

The pressure inlet port should be positioned in the same position as recorded in section 2.2 step 2.2.1.

- 3.3.23 Install tie bar nuts (3-90) onto tie bars (3-20). Torque tighten tie bar nuts, alternately in 100 foot pound / N-m increments, until a final lubricated torque, as listed in Table 4, has been achieved.

Table 4. Tie Bar Nuts

Housing Model	TORQUE (±5%)		Housing Model	TORQUE (±5%)	
	Lbf-ft.	N-m		Lbf-ft.	N-m
G01	120	163	G5	400	542
G2	120	163	G7	500	678
G3	150	203	G8	500	678
G4	150	203	G10	1200	1627

- 3.3.24 Install lockwashers (3-140) onto socket cap screws (3-130).
- 3.3.25 Install and tighten socket cap screws (3-130), with lockwashers (3-140), into outer end cap (3-80).
- 3.3.26 If removed, using pipe dope, install pipe plug (3-120) into outer end cap (3-80).
- 3.3.27 Apply sufficient pneumatic pressure to outer end cap (3-80) pressure inlet port to move the piston to its full inboard position(next to inner end cap).
- 3.3.28 Remove pneumatic pressure from outer end cap (3-80).
- 3.3.29 Install breather assembly (12) in outer end cap (3-80).

NOTE:

Individual actuators may not have reducer bushing (14) depending on port and breather size.

3.4 G2 and G3 Early Model Pneumatic Power Module Reassembly

NOTES:

1. Early G2 and G3 pneumatic power modules were equipped with tie bars that had nuts on both ends of the tie bars (3-20) – double nuts.
2. Refer to Section 2 step 2.1.4 for the correct installation location for piston rod (3-40).
3. THE ACTUATOR MUST BE IN THE APPROPRIATE OVERTRAVEL POSITION. Confirm over-travel position by observing the guide block (1-30) is against the inner wall of housing (1-10).

-
- 3.4.1 Refer to assembly drawing page 2 of 2 Detail "C". Install one rod wiper (4-10) into inner end cap (3-10).
 - 3.4.2 Install one rod bushing (4-20) into inner end cap (3-10).
 - 3.4.3 Coat one Polypak seal (4-30) with lubricant and install, lip first, into inner end cap (3-10).

⚠ CAUTION: INSTALL POLYPAK SEAL CORRECTLY

Install the Polypak seal with energizer ring facing outboard side of inner end cap (3-10).

-
- 3.4.4 Install piston rod (3-40) through inner end cap (3-10).

NOTE:

The piston rod end with retainer grooves to be on the outboard side of inner end cap (3-10).

-
- 3.4.5 Apply lubricant to two sets of rod T-seal components (4-50).

NOTE:

The T-seal is composed of one rubber seal and two split skive-cut back-up rings.

-
- 3.4.5.1 Install two sets of rod T-seals (4-50) into the internal diameter seal grooves of piston (3-30).
 - 3.4.5.2 Install a back-up ring on each side of the T-seal.
 - 3.4.5.3 When installing the back-up rings, do not align the skive-cuts.
 - 3.4.5.4 If the back-up rings are too long and the rings overlap beyond the skive-cuts, then the rings must be trimmed with a razor sharp instrument.
 - 3.4.6 Coat one D-ring seal (4-60) with lubricant and install into the piston external seal groove.

NOTE:

The flat side of the D-ring seal goes down into the seal groove.

- 3.4.7 Install piston (3-30) onto piston rod (3-40).

NOTE:

The cast rib side of the piston is to be facing away from the outboard side of inner end cap (3-10) or position piston (3-30) on the piston rod so that the retainer grooves are on the out board side of the piston.

- 3.4.8 Refer to assembly drawing page 2 of 2 Detail "D". Install O-ring seal (4-70) into the seal groove in the outboard end of piston rod (3-40).
- 3.4.9 Install two split ring halves (3-50) into the outer most groove in piston rod (3-40) and retain by installing the recessed area of piston (3-30) over the two split halves (3-50).
- 3.4.10 Install two split ring halves (3-50) into the piston rod, in back of the piston and retain with retainer ring (3-60).
- 3.4.11 Coat two tie bars (3-20) with lubricant and install by carefully pushing tie bars through piston (3-30) and rod T-seal (4-50).
- 3.4.12 Install two tie bar O-ring seals (4-80) onto the inboard end of tie bars (3-20) and into the O-ring grooves provided.
- 3.4.13 Insert the tie bars through inner end cap (3-10) and screw hex nuts (3-90) onto inboard end of the tie bars.

NOTE:

Screw the tie bars through the hex nuts (3-90) until one complete thread is exposed.

- 3.4.14 Refer to assembly drawing page 2 of 2 Detail "E". Install two tie bar O-ring seals (4-80) onto the outboard end of tie bars (3-20) and into the O-ring grooves provided.
- 3.4.15 Apply lubricant to one O-ring seal (4-40) and install into the outer diameter O-ring groove of outer end cap (3-80).
- 3.4.16 Apply lubricant to the bore of cylinder (3-70).
- 3.4.17 Install lubricated cylinder (3-70) over piston (3-30) and onto inner end cap (3-10). When installing the cylinder over the piston seal tilt cylinder 15 to 30 degrees to piston rod.

⚠ CAUTION: CAREFULLY INSTALL CYLINDER

If needed, when installing the cylinder, hammer on the end of the cylinder only with a non metallic object.

- 3.4.18 Install outer end cap (3-80) over tie bars (3-20) and into cylinder (3-70).

NOTE:

The pressure inlet port should be positioned in the same position as recorded in section 2.2 step 2.2.1.

- 3.4.19 Install tie bar nuts (3-90) onto tie bars (3-20). Torque tighten tie bar nuts, alternately in 100 foot-pound increments, until a final lubricated torque, as listed in the following table, has been achieved.

Table 5. G2 Tie Bar Nuts

Housing Model	TORQUE (±5%)		Housing Model	TORQUE (±5%)	
	Lbf-ft.	N-m		Lbf-ft.	N-m
G2	120	163	G3	150	203

- 3.4.20 Install lockwashers (3-140) onto socket cap screws (3-130).
 3.4.21 Install and tighten socket cap screws (3-130), with lockwashers (3-140), into outer end cap (3-80).
 3.4.22 Install pneumatic power module per Section 5 steps 5.4.

3.5 G01 through G5 M11 Hydraulic Override Cylinder Reassembly

NOTE:

Review Section 3.1 General Reassembly before proceeding with G01 through G5 M11 Hydraulic Override Cylinder Reassembly.

- 3.5.1 Install ram bushing (8-20) into hydraulic ram cover (7-10).
 3.5.2 Install Polypak seal (8-30) into hydraulic ram cover (7-10).

NOTE:

The lip of Polypak seal (8-30) are to face toward the hydraulic override end cap when installed in the hydraulic ram cover.

- 3.5.3 Install rod wiper (8-10) into hydraulic ram cover (7-10).
 3.5.4 Install hydraulic ram (7-20) into hydraulic ram cover (7-10).

NOTE:

When installing the hydraulic ram (7-20) push it through the hydraulic ram cover until the ram is at least flush with the outboard ram cover.

- 3.5.5 Install O-ring seal (8-35) into inner diameter seal groove located at the outboard end of the threads in the hydraulic override end cap (7-70).
- 3.5.6 Install hydraulic ram cover (7-10) into the hydraulic override end cap (7-70) by screwing the ram cover into the end cap until the ram cover bottoms out into the end cap.

NOTE:

For M11 hydraulic override cylinder installations refer to Section 5 step 5.2.

3.6 G7 through G10 M11 Hydraulic Override Cylinder Reassembly

NOTE:

Review Section 3 step 3.1 General Reassembly before proceeding with G7 through G10 M11 Hydraulic Override Cylinder Reassembly.

- 3.6.1 Install Polypak seal (8-30) into hydraulic cylinder assembly (7-10).

NOTE:

The lip of Polypak seal (8-30) will face toward the hydraulic override end cap when installed in the hydraulic cylinder assembly.

- 3.6.2 Install rod bushing (8-20) into hydraulic cylinder assembly (7-10).
- 3.6.3 Install rod wiper (8-10) into hydraulic cylinder assembly (7-10).
- 3.6.4 Install two split ring halves (7-30) into the inner most groove in piston rod (7-20) and retain by installing retainer ring (7-40) onto the split ring halves.
- 3.6.5 Apply hydraulic fluid to O-ring seal (8-50) and install it into the seal groove located between the two split ring grooves on the piston rod (7-20).
- 3.6.6 Install the piston (7-50) onto the piston rod (7-20) and up against the split rings install in step 3.5.4.
- 3.6.7 Install two split ring halves (7-30) into the outboard groove in piston rod (7-20) and retain by installing retainer ring (7-40) onto the split ring halves.
- 3.6.8 Install Polypak seal (8-60) into outer diameter seal groove of piston (7-50).

NOTE:

The lip of Polypak seal (8-60) will face toward the hydraulic override outer end cap (7-70) when installed in the hydraulic cylinder assembly.

- 3.6.9 Install piston bearing (8-40) into outer diameter bearing groove of piston (7-50).
- 3.6.10 Install O-ring seal (8-80) into inner diameter seal groove located in the piston (7-50).
- 3.6.11 Use pipe dope on the threads install pipe plug (7-110) into the vent tube hole in the inboard end of the hydraulic cylinder assembly (7-10).
- 3.6.12 Install vent tube (7-60) into the hydraulic cylinder assembly inboard end.

- 3.6.13 Install the assembled piston rod (7-20) with piston (7-50) into the open end of the hydraulic cylinder assembly and install the piston over the vent tube (7-60).
- 3.6.14 Install O-ring seal (8-90) into the vent tube port located in the outer end cap (7-70).
- 3.6.15 Install O-ring seal (8-70) into the O-ring groove located on the inner diameter of the hydraulic cylinder assembly flange opening.
- 3.6.16 Install the outer end cap (7-70) assembled piston rod (7-20) with piston (7-50) onto the open end of the hydraulic cylinder assembly and over the vent tube (7-60).
- 3.6.17 Install lockwashers (7-90) onto hex cap screws (7-80).
- 3.6.18 Install and tighten hex cap screws (7-80), with lockwashers (7-90) through outer end cap (7-70) and into hydraulic cylinder assembly.

NOTE:

For M11 hydraulic override cylinder installations refer to Section 5 step 5.2.

3.7 Actuator Testing

- 3.7.1 Leakage Test - All areas where leakage to atmosphere may occur are to be checked, using a commercial leak testing solution.

⚠ CAUTION: DO NOT EXCEED MAXIMUM PRESSURE

Pressure applied to the actuator is not to exceed the maximum operating pressure rating listed on the actuator name tag. Test the actuator using a properly adjusted self relieving regulator, with gauge.

- 3.7.2 Cycle the actuator five times at the nominal operating pressure (NOP) as listed on the actuator's name tag or the customer's normal actuator supply pressure. If excessive leakage across the pistons is noted, generally a bubble which breaks three seconds or less after starting to form, cycle the actuator five times as this will allow the seals to seek their proper service condition.

NOTE:

If excessive leakage across the piston remains, the actuator must be disassembled and the cause of leakage must be determined and corrected.

- 3.7.3 Apply NOP pressure to the pressure port in inner end cap (3-10) and allow the actuator to stabilize.
- 3.7.4 Apply a commercial leak testing solution to the following areas:
 - 3.7.4.1 Joint between inner end cap (3-10) and cylinder (3-70). This checks cylinder to inner end cap O-ring seal.
 - 3.7.4.2 The port hole in the outer end cap (3-80). This checks the piston D-seal to cylinder (3-70), O-ring seal (4-70), and rod T-seal (4-50).
 - 3.7.4.3 The vent check port hole in housing. This checks Polypak seal (4-30) that seals piston rod (3-40) to inner end cap (3-10).
 - 3.7.4.4 Remove pressure from the pressure inlet port.

- 3.7.5 If an actuator was disassembled and repaired, the above leakage test must be performed again.
- 3.7.6 Shell Pressure Test – Optional pressure test could be performed on PED certified actuator by applying pressure to both sides of the piston simultaneously for a period of two (2) minutes. If any leakage occurs across a static seal, the unit must be disassembled and the cause of leakage determined and corrected.

⚠ WARNING: PED PRESSURE TESTING

The actuators main pressure bearing parts will be tested in controlled conditions in accordance with the requirement of PED by pressuring both sides of the piston to avoid damage and over torquing of the actuator components. If further future testing in the field is necessary, Emerson should be contacted for guidance.

Section 4: Field Conversions

4.1 Fail Mode Reversal (CW to CCW, or CCW to CW)

- 4.1.1 Remove spring module per Section 5.3.
- 4.1.2 Remove pneumatic power module per Section 5.5.
- 4.1.3 Reinstall the spring module onto the opposite end of housing (1-10) as it was previously located per Section 5.4.
- 4.1.4 Reinstall the override cylinder assembly into spring module per Section 5.2.

4.2 Converting Double-Acting Actuator To Spring-Return With Override Cylinder Assembly

- 4.2.1 Remove Blind End Cap per steps 4.2.1.1 and 4.2.1.2.
 - 4.2.1.1 Remove hex cap screws (5-20), with spring lockwashers (5-30), from blind end cap (5-10).
 - 4.2.1.2 Remove blind end cap (5-10) from end of housing (1-10).
- 4.2.2 If pneumatic power module needs to be relocated due to fail mode requirements (fail counter-clockwise) use Section 5.5 for removal and Section 5.6 for installation.
- 4.2.3 Install Powr Swivl module per Section 5.8.
- 4.2.4 Install the spring module onto the end of housing (1-10) per Section 5.4.
- 4.2.5 Install the override cylinder assembly into spring module per Section 5.2.

Section 5: Module Removal and Installation

5.1 M11 Override Cylinder Removal

- 5.1.1 Shut off and exhaust the operating media from both sides of the actuator's power cylinder.
- 5.1.2 Place the M11 pump control knob (20-320) in the auto position.

NOTE:

Control knob (20-320) is located in front and at the bottom of the M11 pump manifold (20-10).

NOTE:

Using a means of capturing the hydraulic fluid that will be lost during the following steps. Use a bucket, tub, and large container, etc.

- 5.1.3 Remove all the piping from the M11 override cylinder end cap (7-70).
- 5.1.4 M11 Hydraulic override cylinder removal: For models G01 through G5 use step 5.1.5 and for G7 through G10 use step 5.1.6.

⚠ WARNING: DO NOT STAND IN FRONT OF CYLINDER

Confirm that the M11 pump control knob is in the auto position prior to completing step 5.1.5. Do not stand directly in front of the M11 override cylinder when completing step 5.1.5 - Stand to one side or the other.

- 5.1.5 G01 through G5 M11 override cylinder removal.
 - 5.1.5.1 Unscrew and remove hex cap screws (7-80) with lockwashers (7-90) from override cylinder end cap (7-70).
 - 5.1.5.2 Remove override cylinder assembly from spring cartridge assembly (5-10).
- 5.1.6 G7 through G10 M11 override cylinder removal.

⚠ CAUTION: DO NOT REMOVE HEX CAP SCREWS

Do not remove hex cap screws (7-80) from M11 override cylinder at this time. If hex cap screws (7-80) are removed at this time it is possible that hydraulic fluid will be dumped inside the spring cartridge.

- 5.1.6.1 Unscrew and remove hex cap screws (7-100) with lockwashers (7-90) from override cylinder end cap (7-70).

NOTE:

To identify hex cap screws (7-100) from hex cap screws (7-80), hex cap screws (7-100) will be located to the left and right of SR cartridge top dead center and will then be counted as every other hex cap screw. To verify correct hex cap screws check the following table for screw length.

Table 6. Hex Cap Screw Length

Actuator Model	Item 7-80 Length		Item 7-100 Length	
	Inches	mm	Inches	mm
G7	2	50.8	2.75	69.85
G8	3	76.2	4.5	114.3
G10	3.5	88.9	5.0	127

5.1.6.2 Remove override cylinder assembly from spring cartridge assembly (5-10).

5.2 M11 Override Cylinder Installation

- 5.2.1 Install O-ring seal (6-10) into the O-ring groove in the outboard end of spring cartridge assembly (5-10).
- 5.2.2 M11 hydraulic override cylinder installation: For models G01 through G5 use step 5.2.3 and for G7 through G10 use step 5.2.4.
- 5.2.3 G01 through G5 M11 override cylinder installation.
 - 5.2.3.1 Insert M11 hydraulic override cylinder assembly through spring cartridge outer end.
 - 5.2.3.2 Install lockwashers (7-90) on to hex cap screws (7-80).
 - 5.2.3.3 Install hex cap screws (7-80) with lockwashers (7-90) through hydraulic override end cap (7-70) and into outer end of spring cartridge (5-10).
- 5.2.4 G7 through G10 M11 override cylinder installation.
 - 5.2.4.1 Insert M11 hydraulic override cylinder assembly into spring cartridge outer end.
 - 5.2.4.2 Install lockwashers (7-90) on to eight hex cap screws (7-100).
 - 5.2.4.3 Install hex cap screws (7-100) with lockwashers (7-90) through hydraulic override end cap (7-70) and into outer end of spring cartridge (5-10).
- 5.2.5 Torque tighten hex cap screws (7-100) and (7-80), alternately until a final lubricated torque, as listed in the following table, has been achieved.

Table 7. M11 Override Cylinder End Cap to SR Cartridge Screw Torque

Housing Model	TORQUE (±5%)		Housing Model	TORQUE (±5%)	
	Lbf-ft.	N-m		Lbf-ft.	N-m
G01	16	21.68	G5	40	54.2
G2	16	21.68	G7	80	108.4
G3	16	21.68	G8	130	176.15
G4	40	54.2	G10	190	257.45

- 5.2.6 Using pipe dope on threads reinstall all piping between hydraulic override cylinder assembly and the M11 pump.

5.2.7 FLUID FILLING INSTRUCTIONS FOR M11 AND M11-S HYDRAULIC OVERRIDE SYSTEMS:

5.2.7.1 To fluid fill M11 Manual Hydraulic Override System refer to instructions part number 126858.

5.2.7.2 To fluid fill M11-S Manual Hydraulic Override System refer to instructions part number 121960.

5.3 Spring Module Removal

⚠ WARNING: CHECK SPRING CARTRIDGE POSITIONING

The spring cartridge must be checked to verify that the spring(s) are in their extended position before the spring cartridge is removed from the actuator.

NOTES:

1. When the spring module is to be removed it should be removed from the drive module prior to the pneumatic power module removal or disassembly.
2. Review Section 2.1 General Disassembly before proceeding with spring module disassembly.
3. The setting of stop screws (1-180) should be checked and setting recorded before stop screws are loosened or removed.

5.3.1 Shut off and exhaust the operating media from both sides of the actuator's power cylinder.

5.3.2 The M11 override cylinder must be removed prior to spring module removal: Proceed to section 5.1 and complete all steps 5.1.1 through 5.1.6 and then continue with step 5.3.3.

5.3.3 Apply pneumatic pressure to inner end cap (2-40) port "A" to compress the spring enough to move the yoke off the stop screw on the spring module side of the drive module.

5.3.4 Loosen the stop screw nut (1-190) located on the stop screw that is closest to or next to spring module.

5.3.5 Unscrew stop screw (1-180) that is closest to or next to spring module (unscrew or back out until the load is removed from the stop screw).

5.3.6 Remove pneumatic pressure from pressure inlet port of inner end cap (3-10).

⚠ CAUTION: USE HEAVY DUTY SUPPORT EQUIPMENT

Due to the weight and size of spring cartridge assembly (5-10), heavy duty support equipment will be required when removing spring cartridge assembly from the actuator housing. Refer to Section 6 for spring cartridge module weights.

- 5.3.7 The spring cartridge "pre-load" must be removed before spring cartridge assembly (5-10) is removed from housing (1-10). Refer to steps 5.3.4 through 5.3.6 for spring cartridge "pre-load" removal.
- 5.3.8 Remove breather assembly (12) from outer end cap (3-80) port "B".

⚠ CAUTION: DO NOT EXCEED MAXIMUM PRESSURE

The maximum pressure to be applied in step 5.3.9 is 25 PSIG.

- 5.3.9 Apply pneumatic pressure, not to exceed the maximum as indicated in the above "CAUTION", to the pressure inlet port "B" of outer end cap (3-80) to move the spring cartridge tension rod hex nut out of its cast hex seat.

NOTE:

If pneumatic pressure is not available to apply to the pressure inlet port "B" located in outer end cap (3-80) then remove pipe plug (3-120) or if equipped with an extended stop (ES) remove the ES. Using a long rod go through the outer end cap pipe plug or ES vacant port hole and push on the piston rod so as to move the spring cartridge tension rod hex nut out of its cast hex seat.

- 5.3.10 Unscrew the spring cartridge tension rod from the drive module. The tension rod can be rotated for removal by going through the open end of spring cartridge assembly with a square male drive extension.
- 5.3.11 Remove hex cap screws (5-20) with lockwashers (5-30) from housing (1-10).
- 5.3.12 Remove spring cartridge assembly (5-10) from actuator housing (1-10).

⚠ WARNING: DO NOT CUT SPRING CARTRIDGE ASSY

Under no circumstances should the spring cartridge assembly (5-10) be cut apart, as the spring is pre-loaded and the spring cartridge is a weld assembly.

5.4 Spring Module Installation

⚠ CAUTION: USE HEAVY DUTY SUPPORT EQUIPMENT

Due to the weight and size of spring module, heavy duty support equipment will be required when installing spring cartridge module to the actuator housing. For the approximate weight of the spring cartridge refer to Section 6.

⚠ WARNING: VERIFY OVERTRAVEL POSITION

Actuator must be in the appropriate overtravel position (see detail "A" on warning tag attached to spring module access hole cover or to Bettis drawing part number 123650). Confirm overtravel position by observing the guide block (1-30) is against the inner wall of housing (1-10).

NOTE:

The setting of stop screws (1-180) should be checked and setting recorded before stop screws are loosened or removed.

- 5.4.1 On stop screw (1-180), that is located on the same side of the housing as spring cartridge (5-10), loosen stop screw nut (1-190).
- 5.4.2 Unscrew or back out stop screw (1-180) to achieve over-travel as illustrated in detail "A" on warning tag attached to spring module cover plate or to Bettis drawing part number 123650.
- 5.4.3 Install O-ring seal (6-20) into the O-ring groove in the inboard end of spring cartridge assembly (5-10).
- 5.4.4 Using lifting equipment move spring module up to housing (1-10) and align spring cartridge tension rod with extension rod assembly (9-50).

⚠ WARNING: COMPLETE STEP 5.4.5 TO AVOID INJURY

Complete step 5.4.5 to avoid severe injury to personnel or incur major damage to the actuator.

- 5.4.5 SPRING CARTRIDGE TENSION ROD TO ROD EXTENSION INSTALLATION AS FOLLOWS:
 - 5.4.5.1 Using a male square drive extension, go through the open end of spring module (5-10) and rotate the tension rod nut until initial thread engagement is achieved.

NOTE:

Confirm initial thread engagement of rod extension (9-50) to tension rod.

5.4.5.2 After confirming initial thread engagement rotate tension rod into extension rod assembly (9-50) per the following table:

⚠ WARNING: ROTATE TENSION ROD PROPERLY

After initial thread engagement the tension rod must be rotated clockwise the minimum number of turns listed in Table 8.

Table 8. Minimum Turns

ACTUATOR MODEL	TORQUE UNITS	G01	G2	G3	G4	G5	G7	G8	G10
MINIMUM NO TURNS	N/A	N/A	10	10	10	13	14	20	25

⚠ WARNING: DO NOT CROSS-THREAD

When screwing piston rod into extension rod assembly (9-50) make certain that the tension rod and extension rod assembly threads do not cross-thread.

5.4.6 Torque tighten the spring cartridge tension rod as listed in the following table.

Table 9. Spring Cartridge Tension Rod Torque

Housing Model	TORQUE (±5%)		Housing Model	TORQUE (±5%)	
	Lbf-ft.	N-m		Lbf-ft.	N-m
G01	50	68	G5	240	325
G2	90	122	G7	240	325
G3	90	122	G8	240	325
G4	240	325	G10	240	325

- 5.4.7 Install lock washers (5-30) onto hex cap screws (5-20).
- 5.4.8 Install hex cap screws (5-20) with lockwashers (5-30) through housing (1-10) and into spring cartridge assembly (5-10) and tighten.
- 5.4.9 Install O-ring seal (6-10) into the O-ring groove in the outboard end of spring cartridge assembly (5-10).
- 5.4.10 M11 Hydraulic override cylinder installation: For models G2 through G5 use step 5.4.11 and for G7 through G10 use step 5.4.12.
- 5.4.11 G2 through G5 M11 override cylinder installation.
 - 5.4.11.1 Insert M11 hydraulic override cylinder assembly into spring cartridge outer end.
 - 5.4.11.2 Install lockwashers (7-90) on to eight hex cap screws (7-80).
 - 5.4.11.3 Install eight hex cap screws (7-80) with lockwashers (7-90) through end cap (7-70) and into outer end of spring cartridge (5-10).
- 5.4.12 G7 through G10 M11 override cylinder installation.
 - 5.4.12.1 Insert M11 hydraulic override cylinder assembly into spring cartridge outer end.
 - 5.4.12.2 Install lockwashers (7-80) on to eight hex cap screws (7-100).

- 5.4.12.3 Install eight hex cap screws (7-100) with lockwashers (7-90) through end cap (7-70) and into outer end of spring cartridge (5-10).
- 5.4.13 Torque tighten hex cap screws (7-100) and (7-80), alternately until a final lubricated torque, as listed in the following table, has been achieved.

Table 10. M11 Override Cylinder End Cap to SR Cartridge Screw Torque

Housing Model	TORQUE (±5%)		Housing Model	TORQUE (±5%)	
	Lbf-ft.	N-m		Lbf-ft.	N-m
G01	16	21.68	G5	40	54.2
G2	16	21.68	G7	80	108.4
G3	16	21.68	G8	130	176.15
G4	40	54.2	G10	190	257.45

- 5.4.14 Using pipe dope on threads reinstall all piping between hydraulic override cylinder assembly and the M11 pump.
- 5.4.15 FLUID FILLING INSTRUCTIONS FOR M11 AND M11-S HYDRAULIC OVERRIDE SYSTEMS:
 - 5.4.15.1 To fluid fill M11 Manual Hydraulic Override System refer to instructions part number 126858.
 - 5.4.15.2 To fluid fill M11-S Manual Hydraulic Override System refer to instructions part number 121960.
- 5.4.16 If removed install stop screw nuts (1-190) onto stop screws (1-180).
- 5.4.17 If removed install O-ring (2-90) onto stop screws (1-180).
- 5.4.18 If removed install two stop screws (1-180) into two stop screw holes on the front of housing (1-10).
- 5.4.19 Adjust both stop screws (1-180) back to settings recorded earlier in Section 5.
- 5.4.20 Tighten both stop screw nuts (1-190) securely.

5.5 Pneumatic Power Module Removal

⚠ CAUTION: USE HEAVY DUTY SUPPORT EQUIPMENT

Due to the weight and size of power module, heavy duty support equipment will be required when removing power module from the actuator housing. Refer to Section 6 for Pneumatic Power Module Weights.

- 5.5.1 Remove pipe plug (3-120) from outer end cap (3-80).
- 5.5.2 Remove hex cap screws (3-100) with lockwashers (3-110) from housing (1-10).
- 5.5.3 Using a male square drive extension, go through outer end cap (3-80) and unscrew piston rod (3-40) from extension rod assembly (1-50).

NOTE:

When removing power module from housing (1-10) be careful not to loose O-ring seal (4-90).

- 5.5.4 Remove power module from actuator housing (1-10).

5.6 Pneumatic Power Module Installation

NOTE:

Reinstall the power module onto the opposite side of housing (1-10) as it was previously located.

- 5.6.1 Check to verify that O-ring seal (4-90) is properly seated in its seal groove located on the housing side of inner end cap (3-10).
-

NOTE:

G2 and G3 models confirm that the two inboard hex nuts (3-90) flats are aligned to fit into the slot located in the end of housing (1-10).

- 5.6.2 Using lifting equipment move the power module up to housing (1-10) and align piston rod (3-40) with extension rod assembly (1-50).
- 5.6.3 Using a male square drive extension, go through outer end cap (3-80) and screw piston rod (3-40) into extension rod assembly (1-50).

⚠ CAUTION: DO NOT CROSS-THREAD PISTON RODS

When screwing piston rod into extension rod assembly (1-50) make certain that the piston rod and extension rod assembly threads do not cross-thread.

- 5.6.4 Torque tighten piston rod (3-40) as follows:
- 5.6.4.1 G2 and G3 torque to 90 foot pounds lubricated.
 - 5.6.4.2 G4 and G10 torque to 240 foot pounds lubricated.
- 5.6.5 Install lock washers (3-110) onto hex cap screws (3-100).
- 5.6.6 Install and tighten hex cap screws (3-100) with lockwashers (3-110) through housing (1-10) and screw into inner end cap (3-10).
- 5.6.7 Using pipe dope, install pipe plug (3-120) into outer end cap (3-80).

5.7 Powr Swivl Removal

- 5.7.1 Push the guide block to the side of housing (1-10) that will expose the extension rod assembly (1-50).

NOTE:

The guide block can be moved by inserting a long non metallic rod through the hole where the blind end cap was removed and pushing on the guide block.

- 5.7.2 Refer to assembly drawing sheet 2 Detail "B". Use Bettis tool part number as listed in chart in section 1 step 1.5.2 to remove retainer nut assembly (1-60) from the guide block (1-30).

⚠ CAUTION: CAREFULLY HANDLE SPHERICAL WASHERS

When removing rod extension assembly from guide block be careful not to drop one of the spherical washers inside the housing.

- 5.7.3 Remove rod extension assembly (1-50) from guide block (1-30).

NOTE:

One spherical washer (1-40) will be removed from guide block (1-30) when extension rod assembly is removed.

- 5.7.4 Remove the remaining spherical washer (1-40) from guide block (1-30).

5.8 Powr Swivl Module Installation

⚠ WARNING: VERIFY OVERTRAVEL POSITION

The actuator must be in the appropriate overtravel position. Confirm overtravel position by observing the guide block (1-30) is against the inner wall of housing (1-10).

- 5.8.1 Push the guide block to the required side of the housing (1-10).

NOTE:

The guide block can be moved by inserting a long rod through either end of the housing and pushing on the guide block.

- 5.8.2 Lubricate two spherical washers (1-40), and one extension rod assembly (1-50).
5.8.3 Install one spherical washer (1-40) into the side of guide block (1-30).

NOTE:

The spherical side of washer (1-40) will be facing to the outside of guide block (1-30).

- 5.8.4 Install second spherical washer (1-40) over threaded end of extension rod assembly (1-50).

NOTE:

The spherical side of the washer will go on the extension rod assembly facing the head of the extension rod assembly.

- 5.8.5 Install extension rod assembly (1-50) into right of guide block (1-30) and up against the first spherical washer (1-40).
5.8.6 Install extension retainer nut assembly (1-60) over extension rod assembly (1-50) and screw into guide block (1-30).
5.8.7 Tighten extension retainer nut assembly (1-60) until extension rod assembly (1-50) cannot move. Back off the extension retainer nut assembly (1-60) just enough to allow for extension rod assembly (1-50) to move freely.

Section 6: Actuator Support Information

6.1 M11 Hydraulic Override System Fluid Volume

Table 11. M11 Hydraulic Override System Fluid Volume

ACTUATOR SIZE		G01	G2	G3	G4	G5	G7	G8	G10
APPROX VOLUME FLUID FOR M11 SYSTEM	Quarts	1.6	1.8	2.0	3.6	10.2	9.7	15.9	27.0
	Liters	1.8	1.7	1.9	3.4	9.6	9.1	15.1	25.6

6.2 Module Weights by Item Number and Actuator Housing Size

Table 12. Module Weight by Item Number and Actuator Housing Size

ITEM NO.		G01 WT.	G2 WT.	G3 WT.	G4 WT.	G5 WT.	G7 WT.	G8 WT.	G10 WT.	MODULE DESCRIPTION
1	Lbs.	83	110	162	280	545	1025	1495	2550	Drive Module
	Kg	38	50	73	127	247	465	678	1157	
3	Lbs.	69	N/A	N/A	N/A	N/A	N/A	N/A	N/A	8" Dia. Power
	Kg	31	N/A	N/A	N/A	N/A	N/A	N/A	N/A	
3	Lbs.	68	80	N/A	N/A	N/A	N/A	N/A	N/A	9" Dia. Power
	Kg	30.5	36	N/A	N/A	N/A	N/A	N/A	N/A	
3	Lbs.	75	73.5	88	N/A	N/A	N/A	N/A	N/A	10" Dia. Power
	Kg	34	33	40	N/A	N/A	N/A	N/A	N/A	
3	Lbs.	86	86	104	130	N/A	N/A	N/A	N/A	12" Dia. Power
	Kg	39	39	47	59	N/A	N/A	N/A	N/A	
3	Lbs.	96	96	114	145	N/A	N/A	N/A	N/A	14" Dia. Power
	Kg	44	44	51	66	N/A	N/A	N/A	N/A	
3	Lbs.	N/A	135	145	168	295	N/A	N/A	N/A	16" Dia. Power
	Kg	N/A	61	66	76	134	N/A	N/A	N/A	
3	Lbs.	N/A	N/A	235	260	305	585	N/A	N/A	20" Dia. Power
	Kg	N/A	N/A	107	118	138	265	N/A	N/A	
3	Lbs.	N/A	N/A	N/A	340	410	735	911	N/A	24" Dia. Power
	Kg	N/A	N/A	N/A	154	186	334	413	N/A	
3	Lbs.	N/A	N/A	N/A	505	590	810	1225	1120	28" Dia. Power
	Kg	N/A	N/A	N/A	229	268	367	556	508	
3	Lbs.	N/A	N/A	N/A	N/A	977	1100	1260	1440	32" Dia. Power
	Kg	N/A	N/A	N/A	N/A	443	499	572	653	
3	Lbs.	N/A	N/A	N/A	N/A	1243	1400	1525	1755	36" Dia. Power
	Kg	N/A	N/A	N/A	N/A	564	653	692	796	
3	Lbs.	N/A	N/A	N/A	N/A	N/A	N/A	1975	2205	40" Dia. Power
	Kg	N/A	N/A	N/A	N/A	N/A	N/A	896	1000	
3	Lbs.	N/A	N/A	N/A	N/A	N/A	N/A	N/A	N/A	44" Dia. Power
	Kg	N/A	N/A	N/A	N/A	N/A	N/A	N/A	N/A	

Table 12 (continued).....

ITEM NO.		G01 WT.	G2 WT.	G3 WT.	G4 WT.	G5 WT.	G7 WT.	G8 WT.	G10 WT.	MODULE DESCRIPTION
3	Lbs.	N/A	N/A	N/A	N/A	N/A	N/A	N/A	N/A	48" Dia. Power
	Kg	N/A	N/A	N/A	N/A	N/A	N/A	N/A	N/A	
3	Lbs.	N/A	N/A	N/A	N/A	N/A	N/A	N/A	N/A	52" Dia. Power
	Kg	N/A	N/A	N/A	N/A	N/A	N/A	N/A	N/A	
5	Lbs.	160	225	320	564	975	2740	3545	4975	SR1 Spring
	Kg	73	102	145	256	442	1243	1608	2257	
5	Lbs.	158	215	310	549	980	2630	2345	4515	SR2 Spring
	Kg	72	98	141	249	445	1193	1064	2048	
5	Lbs.	153	215	295	534	925	2410	3085	4095	SR3 Spring
	Kg	153	98	295	534	925	2410	3085	4095	
5	Lbs.	144	200	280	474	860	2210	N/A	3735	SR4 Spring
	Kg	65	91	127	215	390	1002	N/A	1694	
5	Lbs.	N/A	200	N/A	N/A	N/A	N/A	N/A	N/A	SRA5 Spring
	Kg	N/A	91	N/A	N/A	N/A	N/A	N/A	N/A	
5	Lbs.	N/A	180	N/A	N/A	N/A	N/A	N/A	N/A	SRA6 Spring
	Kg	N/A	82	N/A	N/A	N/A	N/A	N/A	N/A	
7	Lbs.	18	34	47	82	100	181	270	530	M11 SR Override Cylinder
	Kg	8.2	15.3	21.2	36.9	45	81.45	1275	239	
2	Lbs.	35	35	35	45	50	35	45	50	M11 SR Pump / Reservoir
	Kg	14.5	14.5	14.5	20.4	22.7	14.5	20.4	22.7	

6.3 G01 Tool Style and Wrench Size

Table 13. G01 Tool Style and Wrench Size

ITEM NO.	WRENCH SIZE	ITEM QTY	LOCATION OR DESCRIPTION	RECOMMENDED TOOL STYLE
1-110	9/16"	4	Hex Cap Screws	Socket
1-160	1/2"	4	Hex Cap Screws	Socket
1-180	3/8" Sq.	2	Stop Screws	Open End or Adjustable
1-190	1-15/16"	2	Hex Jam Nuts	Open End or Adjustable
3-20	3/8"	2	Tie Bar (flats)	Open End or Adjustable
3-40	3/8" Sq.	1	Piston Rod	Male Drive
3-90	1-1/8"	2	Standard Hex Nuts	Socket
3-100	9/16"	4	Hex Cap Screws	Socket
3-120	5/8" Sq.	1	Pipe Plug	Open End or Adjustable
3-130	3/16"	2	Socket Cap Screws	Allen
5-20	9/16"	4	Hex Cap Screws	Socket
7-80	9/16"	4	Hex Cap Screws	Socket
7-110	1/8" Sq.	1	Square Head Pipe Plug	Open End or Adjustable
7-120	9/16" Sq.	1	Square Head Pipe Plug	Square Head Pipe Plug
12	1"	1	Breather Assembly	Socket
13	3/4"	2	Vent Check Assembly	Open End
-	3/8" Sq.	1	Tension rod	Male Drive

6.4 G2 Tool Style and Wrench Size

Table 14. G2 Tool Style and Wrench Size

ITEM NO.	WRENCH SIZE	ITEM QTY	LOCATION OR DESCRIPTION	RECOMMENDED TOOL STYLE
1-110	9/16"	6	Hex Cap Screws	Socket
1-160	9/16"	4	Hex Cap Screws	Socket
1-180	3/8" Sq.	2	Stop Screws	Open End or Adjustable
1-190	1-1/8"	2	Hex Jam Nuts	Open End or Adjustable
3-20	3/8"	2	Tie Bar (flats)	Open End or Adjustable
3-40	3/8" Sq.	1	Piston Rod	Male Drive
3-90	1-1/8"	4	Standard Hex Nuts	Socket
3-100	9/16"	4	Hex Cap Screws	Socket
3-120	5/8" Sq.	1	Pipe Plug	Open End or Adjustable
3-130	3/16"	2	Socket Cap Screws	Allen
5-20	9/16"	6	Hex Cap Screws	Socket
7-80	9/16"	4	Hex Cap Screws	Socket
7-110	1/8" Sq.	1	Square Head Pipe Plug	Open End or Adjustable
7-120	1/2" Sq.	1	Square Head Pipe Plug	Open End or Adjustable
12	1"	1	Breather Assembly	Open End
13	3/4"	2	Vent Check Assembly	Open End
-	3/8" Sq.	1	Tension rod	Male Drive

6.5 G3 Tool Style and Wrench Size

Table 15. G3 Tool Style and Wrench Size

ITEM NO.	WRENCH SIZE	ITEM QTY	LOCATION OR DESCRIPTION	RECOMMENDED TOOL STYLE
1-110	9/16"	8	Hex Cap Screws	Socket
1-160	9/16"	4	Hex Cap Screws	Socket
1-180	1/2" Sq.	2	Stop Screws	Open End or Adjustable
1-190	1-5/16"	2	Hex Jam Nuts	Open End or Adjustable
3-20	1/2"	2	Tie Bar (flats)	Open End or Adjustable
3-40	3/8" Sq.	1	Piston Rod	Male Drive
3-90	1-5/16"	4	Standard Hex Nuts	Socket
3-100	9/16"	6	Hex Cap Screws	Socket
3-120	5/8" Sq.	1	Pipe Plug	Open End or Adjustable
3-130	3/16"	2	Socket Cap Screws	Allen
5-20	9/16"	6	Hex Cap Screws	Socket
7-80	9/16"	6	Hex Cap Screws	Socket
7-110	1/8" Sq.	1	Square Head Pipe Plug	Open End or Adjustable
7-120	1/2" Sq.	1	Square Head Pipe Plug	Open End or Adjustable
12	1"	1	Breather Assembly	Open End
13	3/4"	2	Vent Check Assembly	Open End
-	3/8" Sq.	1	Tension rod	Male Drive

6.6 G4 Tool Style and Wrench Size

Table 16. G4 Tool Style and Wrench Size

ITEM NO.	WRENCH SIZE	ITEM QTY	LOCATION OR DESCRIPTION	RECOMMENDED TOOL STYLE
1-110	9/16"	8	Hex Cap Screws	Socket
1-160	9/16"	4	Hex Cap Screws	Socket
1-180	3/4" Sq.	2	Stop Screws	Open End or Adjustable
1-190	1-13/16"	2	Hex Jam Nuts	Open End or Adjustable
3-20	5/8"	2	Tie Bar (flats)	Open End or Adjustable
3-40	1/2" Sq.	1	Piston Rod	Male Drive
3-90	1-5/8"	2	Standard Hex Nuts	Socket
3-100	3/4"	6	Hex Cap Screws	Socket
3-120	5/8" Sq.	1	Pipe Plug	Open End or Adjustable
3-130	3/16"	2	Socket Cap Screws	Allen
5-20	3/4"	6	Hex Cap Screws	Socket
7-80	3/4"	6	Hex Cap Screws	Socket
7-110	1/8" Sq.	1	Square Head Pipe Plug	Open End or Adjustable
7-120	1/2" Sq.	1	Square Head Pipe Plug	Open End or Adjustable
12	1"	1	Breather Assembly	Open End
13	3/4"	2	Vent Check Assembly	Open End
-	3/4"	1	Tension rod	Male Drive

6.7 G5 Tool Style and Wrench Size

Table 17. G5 Tool Style and Wrench Size

ITEM NO.	WRENCH SIZE	ITEM QTY	LOCATION OR DESCRIPTION	RECOMMENDED TOOL STYLE
1-110	3/4"	8	Hex Cap Screws	Socket
1-120	3/4"	4	Hex Cap Screws	Socket
1-160	9/16"	6	Hex Cap Screws	Socket
1-180	7/8" Sq.	2	Stop Screws	Open End or Adjustable
1-190	2-3/8"	2	Heavy Hex Jam Nuts	Open End or Adjustable
3-20	1/2" Sq.	2	Tie Bar (flats)	Open End or Adjustable
3-40	1/2" Sq.	1	Piston Rod	Male Drive
3-90	2"	2	Standard Hex Nuts	Socket
3-100	3/4"	8	Hex Cap Screws	Socket
3-120	1-1/8" Sq.	1	Pipe Plug	Open End or Adjustable
3-130	3/16"	2	Socket Cap Screws	Allen
5-20	3/4"	8	Hex Cap Screws	Socket
7-80	3/4"	8	Hex Cap Screws	Socket
7-110	1/8" Sq.	1	Square Head Pipe Plug	Open End or Adjustable
7-120	1/2" Sq.	1	Square Head Pipe Plug	Open End or Adjustable
12	1"	1	Breather Assembly	Open End
13	3/4"	2	Vent Check Assembly	Open End
-	3/4"	1	Tension rod	Male Drive

6.8 G7 Tool Style and Wrench Size

Table 18. G7 Tool Style and Wrench Size

ITEM NO.	WRENCH SIZE	ITEM QTY	LOCATION OR DESCRIPTION	RECOMMENDED TOOL STYLE
1-110	3/4"	8	Hex Cap Screws	Socket
1-120	3/4"	4	Hex Cap Screws	Socket
1-160	9/16"	8	Hex Cap Screws	Socket
1-180	1"	2	Stop Screws	Open End or Adjustable
3-20	3/4" Sq.	2	Tie Bar (female square)	Open End or Adjustable
3-40	3/4" Sq.	1	Piston Rod	Male Drive
3-90	2-3/8"	2	Standard Hex Nuts	Socket
3-100	15/16"	8	Hex Cap Screws	Socket
3-120	1-1/8" Sq.	1	Pipe Plug	Open End or Adjustable
3-130	3/16"	2	Socket Cap Screws	Allen
5-20	15/16"	8	Hex Cap Screws	Socket
7-80	15/16"	8	Hex Cap Screws	Socket
7-100	15/16"	8	Hex Cap Screws	Socket
7-110	9/16"	1	Flush Socket Head Pipe Plug	Allen
7-130	9/32" Sq.	1	Square Head Pipe Plug	Open End or Adjustable
12	1"	1	Breather Assembly	Open End
13	3/4"	2	Vent Check Assembly	Open End
-	3/4"	2	Tension rod	Male Drive

6.9 G8 Tool Style and Wrench Size

Table 19. G8 Tool Style and Wrench Size

ITEM NO.	WRENCH SIZE	ITEM QTY	LOCATION OR DESCRIPTION	RECOMMENDED TOOL STYLE
1-110	3/4"	12	Hex Cap Screws	Socket
1-120	3/4"	4	Hex Cap Screws	Socket
1-160	9/16"	8	Hex Cap Screws	Socket
1-180	1-1/4"	2	Stop Screws	Open End or Adjustable
3-20	3/4" Sq.	2	Tie Bar (female square)	Open End or Adjustable
3-40	3/4" Sq.	1	Piston Rod	Male Drive
3-90	2-3/4"	2	Heavy Hex Nuts	Socket
3-100	1-1/8"	8	Hex Cap Screws	Socket
3-120	1-5/16" Sq.	1	Pipe Plug	Open End or Adjustable
3-130	3/16"	2	Socket Cap Screws	Allen
5-20	1-1/8"	8	Hex Cap Screws	Socket
7-80	1-1/8"	8	Hex Cap Screws	Socket
7-100	1-1/8"	8	Hex Cap Screws	Socket
7-110	9/16"	1	Flush Socket Head Pipe Plug	Allen
7-130	9/32" Sq.	1	Square Head Pipe Plug	Open End or Adjustable
12	1"	1	Breather Assembly	Open End
13	3/4"	2	Vent Check Assembly	Open End
-	3/4"	1	Tension rod	Male Drive

6.10 G10 Tool Style and Wrench Size

Table 20. G10 Tool Style and Wrench Size

ITEM NO.	WRENCH SIZE	ITEM QTY	LOCATION OR DESCRIPTION	RECOMMENDED TOOL STYLE
1-110	3/4"	16	Hex Cap Screws	Socket
1-120	3/4"	4	Hex Cap Screws	Socket
1-160	9/16"	8	Hex Cap Screws	Socket
1-180	1-1/2"	2	Stop Screws	Open End or Adjustable
3-20	3/4" Sq.	2	Tie Bar (female square)	Open End or Adjustable
3-40	3/4" Sq.	1	Piston Rod	Male Drive
3-90	3-1/2"	2	Heavy Hex Nuts	Socket
3-100	1-5/16"	8	Hex Cap Screws	Socket
3-120	1-5/16" Sq.	1	Pipe Plug	Open End or Adjustable
3-130	3/16"	2	Socket Cap Screws	Allen
5-20	1-1/8"	8	Hex Cap Screws	Socket
7-80	1-5/16"	8	Hex Cap Screws	Socket
7-100	1-5/16"	8	Hex Cap Screws	Socket
7-110	9/16"	1	Flush Socket Head Pipe Plug	Allen
7-130	9/32" Sq.	1	Square Head Pipe Plug	Open End or Adjustable
12	1"	1	Breather Assembly	Open End
13	3/4"	2	Vent Check Assembly	Open End
-	3/4"	1	Tension rod	Male Drive

Section 7: Troubleshooting

7.1 Fault Insertion

In the unlikely event of a fault developing, the following Fault Location Table is provided to assist the service engineer to perform troubleshooting. This table is designed to cover as wide a range of Emerson Bettis actuators as possible. Reference to equipment not supplied should be ignored.

Table 21. Fault Location Table

SYMPTOM	POTENTIAL CAUSES	REMEDY
Erratic movement	Irregular supply of operating medium	Check operating medium for consistent supply pressure and correct as necessary
	Inadequate lubrication	Dismantle, relubricate and reassemble
	Worn parts	Dismantle. Visually inspect for significant wear. Actuator replacement may be required
	Defective valve	Consult the valve OEM's documentation
Short stroke	Incorrectly set stops (valve and /or actuator)	Check the position of the travel stops and readjust as necessary
	Hardened grease	Dismantle, remove any hard grease, relubricate and reassemble
	Debris left in the cylinder or housing during maintenance	Disassemble cylinder assembly to remove debris. Reassemble cylinder assembly as necessary
	Defective valve	Consult the valve manufacturer's documentation
Apparent lack of torque	Inadequate supply pressure	Ensure supply pressure is above the minimum operating pressure of the actuator and that output torque produced at supply pressure exceeds valve torque demand
	Incorrect speed control settings	Adjust speed controls to increase flow
	Exhaust port blocked	Remove and clean the exhaust port silencers and replace
	Pipe work blocked, crushed or leaking	Examine the pipe work for blockages, crushed pipe or leakage. Clear or replace as necessary
	Defective controls	Examine the controls, refurbish or renew as necessary. Refer to component manufacturer's documentation
	Defective piston seal	Dismantle the cylinder assembly, remove the defective piston seal. Fit new seal and reassemble
	Defective rod seal	Dismantle the cylinder assembly, remove the defective rod seal. Fit new seal and reassemble
	Defective housing seal	Dismantle the housing assembly, remove the defective seal. Fit new seal and reassemble
	High valve torque or valve seized	Consult the valve OEM documentation

7.2 Operational Test

7.2.1 Full Stroke Test

The “Full Stroke Test” (“On-line”) must be performed to satisfy the PFD_{AVG} (average probability of failure on demand) value. The full stroke test frequencies will be defined by the final installer to achieve the defined SIL level.

7.2.1.1 Procedure

7.2.1.1.1 Stroke the actuator/valve assembly two complete open/close cycles with complete closing of the valve.

7.2.1.1.2 Verify the open/close cycles functioned correctly (e.g. check locally, or automatically via Logic solver, the correct movement of the actuator/valve).

Upon successful completion of the above described Full Stroke Test procedure, the “Test Coverage” can be considered 99%.

7.2.2 Partial Stroke Test (when requested)

The “Partial Stroke Test” (“On-line”) can be performed to improve the PFD_{AVG} value and to satisfy PFD_{AVG} (average probability of failure on demand) value. A typical partial stroke value is 15% of the stroke and the recommended test interval is about every one to three months.

7.2.2.1 Procedure

7.2.2.1.1 Operate the actuator/valve assembly for No° 1 open/close cycles 15% of the stroke.

7.2.2.1.2 Verify the partial stroke test functioned correctly (e.g. check locally, or automatically via Logic solver, or via the PST system the correct movement of the actuator/valve was 15% of the stroke).

NOTE:

The above test is only applicable on systems equipped with a partial stroke feature.

Section 8: Removal and Decommissioning

8.1 Removal and Decommissioning

⚠ WARNING: FOLLOW PROPER PROCEDURE

Always follow safe work practices remove and disassemble G-Series actuator.

The below basic procedure should not supersede or replace any customer's plant safety or work procedures. If a conflict arises between this procedure and the customer's procedures, the differences should be resolved in writing between an authorized customer's representative and an authorized Emerson/Bettis representative.

⚠ CAUTION: ISOLATE AND POWER OFF ACTUATOR

Make sure actuator is isolated before removing from valve. Turn OFF the power medium and bleed off all pressure first, including storage tank (if present). Next, bleed off pilot pressure, disconnect: pneumatic pressure supply, pilot tubing and electrical wiring (if equipped).

Before starting the disassembly, a large area should be created around the actuator so to allow any kind of movement.

Separate the parts composing the actuator according to their nature (ex. metallic, and plastic materials, fluids etc.) and send them to differentiated waste collection sites, as provided for by the laws and provisions in force.

- 8.1.1 Drain tanks and remove tubing from actuator. Remove accessories (if equipped) and controls from actuator.
- 8.1.2 Remove all equipment mounted on top of actuator (limit switches, end of stroke valve, and relevant pneumatic/electric connection, etc.)
- 8.1.3 Remove mounting bolts and actuator is ready to be removed from valve. For complete actuator tear down refer to Section 2 of the manual.

Section 9: Document Revision

Table 22. Revision Overview

ECN	DATE	REV		BY *	DATE
Released	Dec. 2001	A		B. Cornelius	Dec. 2001
19110	July 2006	B	UPDATED	C. Ross	July 2006
VAWCO2746	Aug. 2015	C	UPDATED	C. Rico	Aug. 2015

* Signatures on file Bettis, Houston, Texas

Appendix A: List of Tables

Table 1.	G-Series Models	3
Table 2.	Housing Cover Screw Quantity and Torque	17
Table 3.	Piston Rod Torque Information	18
Table 4.	Tie Bar Nuts	20
Table 5.	G2 Tie Bar Nuts	23
Table 6.	Hex Cap Screw Length	29
Table 7.	M11 Override Cylinder End Cap to SR Cartridge Screw Torque	29
Table 8.	Minimum Turns	33
Table 9.	Spring Cartridge Tension Rod Torque	33
Table 10.	M11 Override Cylinder End Cap to SR Cartridge Screw Torque	34
Table 11.	M11 Hydraulic Override System Fluid Volume	38
Table 12.	Module Weight by Item Number and Actuator Housing Size	38
Table 13.	G01 Tool Style and Wrench Size	39
Table 14.	G2 Tool Style and Wrench Size	40
Table 15.	G3 Tool Style and Wrench Size	40
Table 16.	G4 Tool Style and Wrench Size	41
Table 17.	G5 Tool Style and Wrench Size	41
Table 18.	G7 Tool Style and Wrench Size	42
Table 19.	G8 Tool Style and Wrench Size	42
Table 20.	G10 Tool Style and Wrench Size	43
Table 21.	Fault Location Table	44
Table 22.	Revision Overview	47

Appendix B: List of Drawings

B.1 Part No. 121410, G1/2/3/4/5-SRX-H Pneumatic Assembly, Sheet 1 of 2

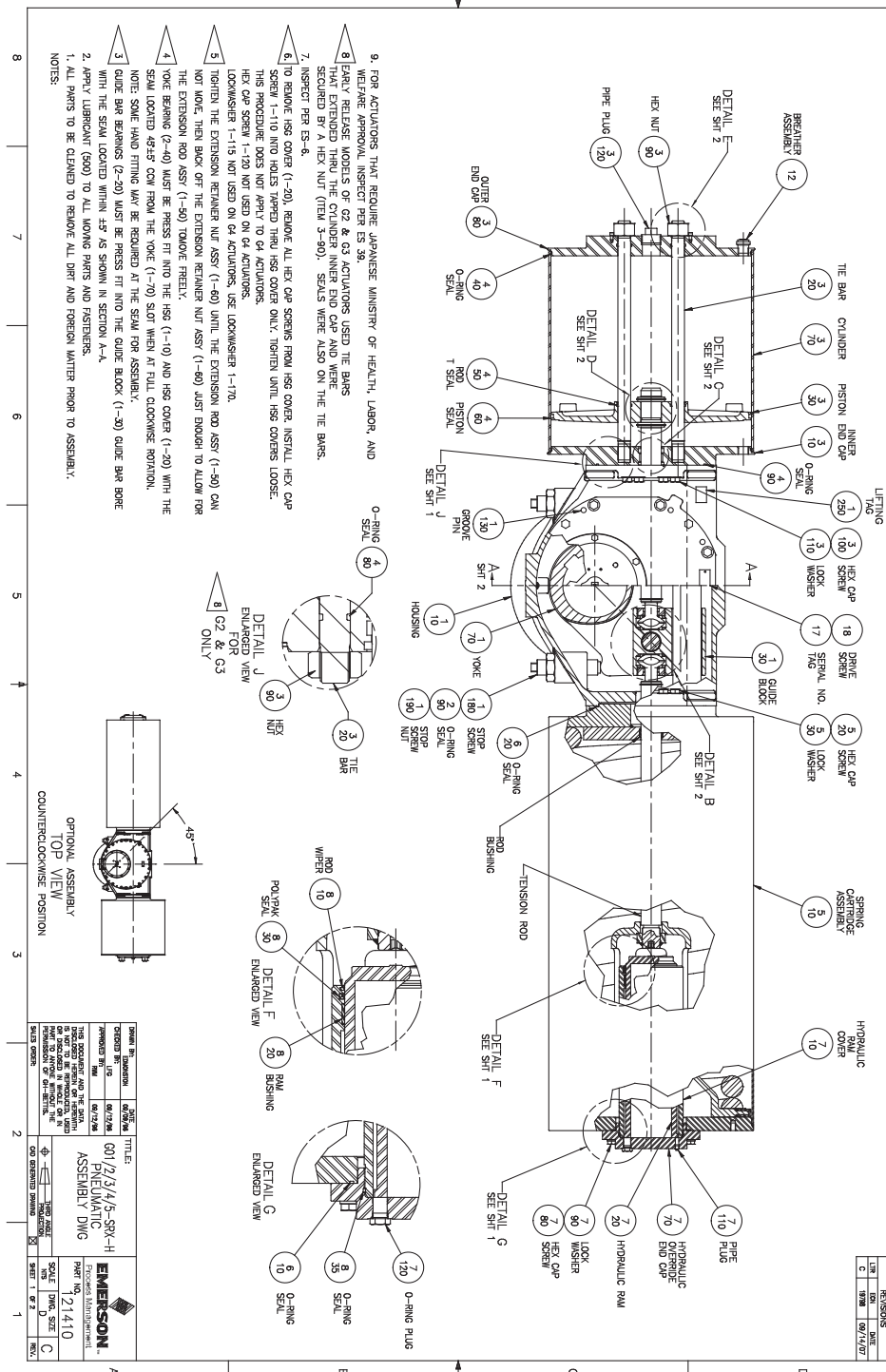

B.4 Part No. 121411, G7/8/10/13-SRX-H Pneumatic Assembly Drawing, Sheet 2 of 2

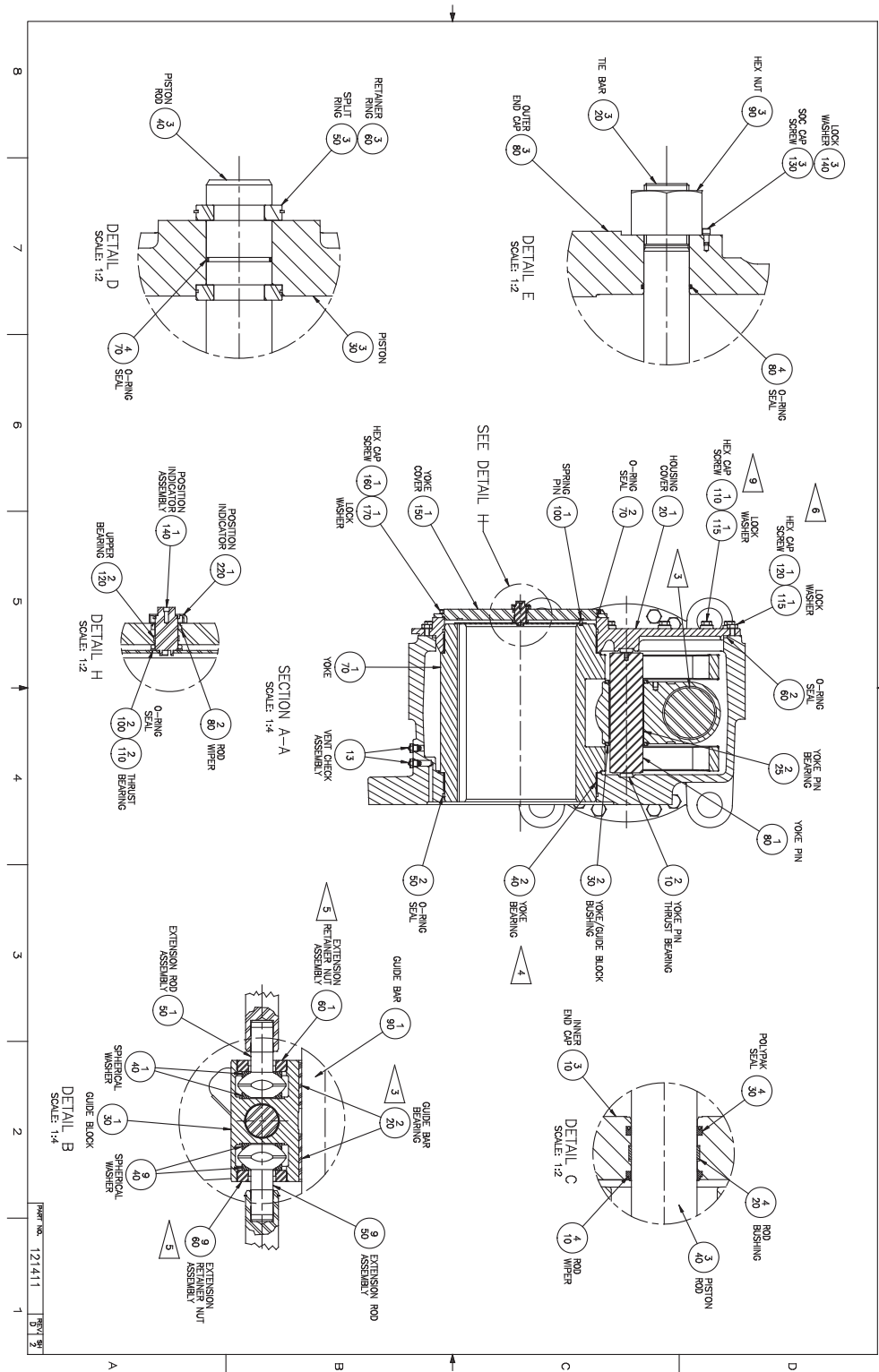

B.5 Part No. 126567, M11 Assembly Drawing, Sheet 1 of 5

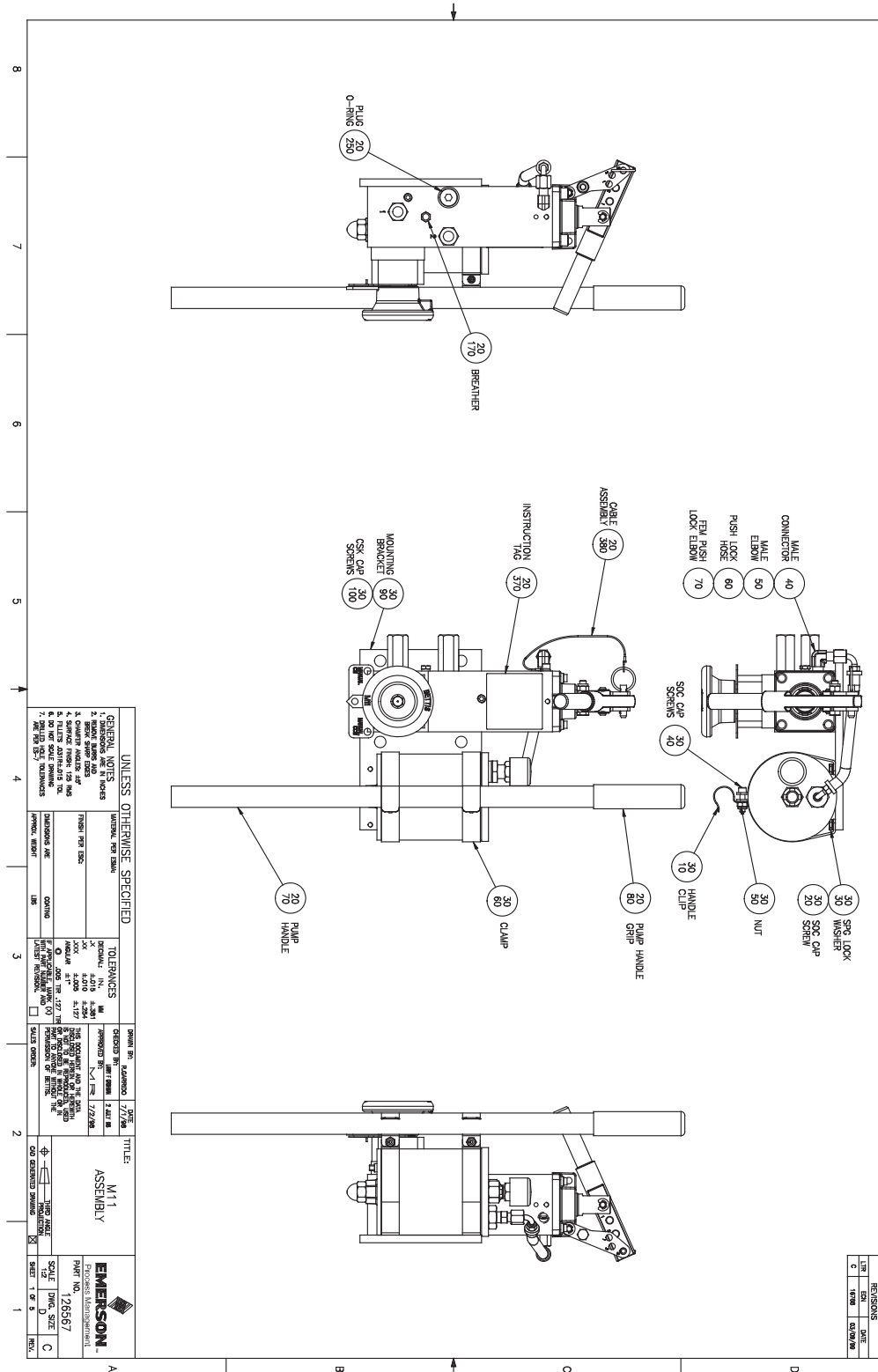

B.6 Part No. 126567, M11 Assembly Drawing, Sheet 2 of 5

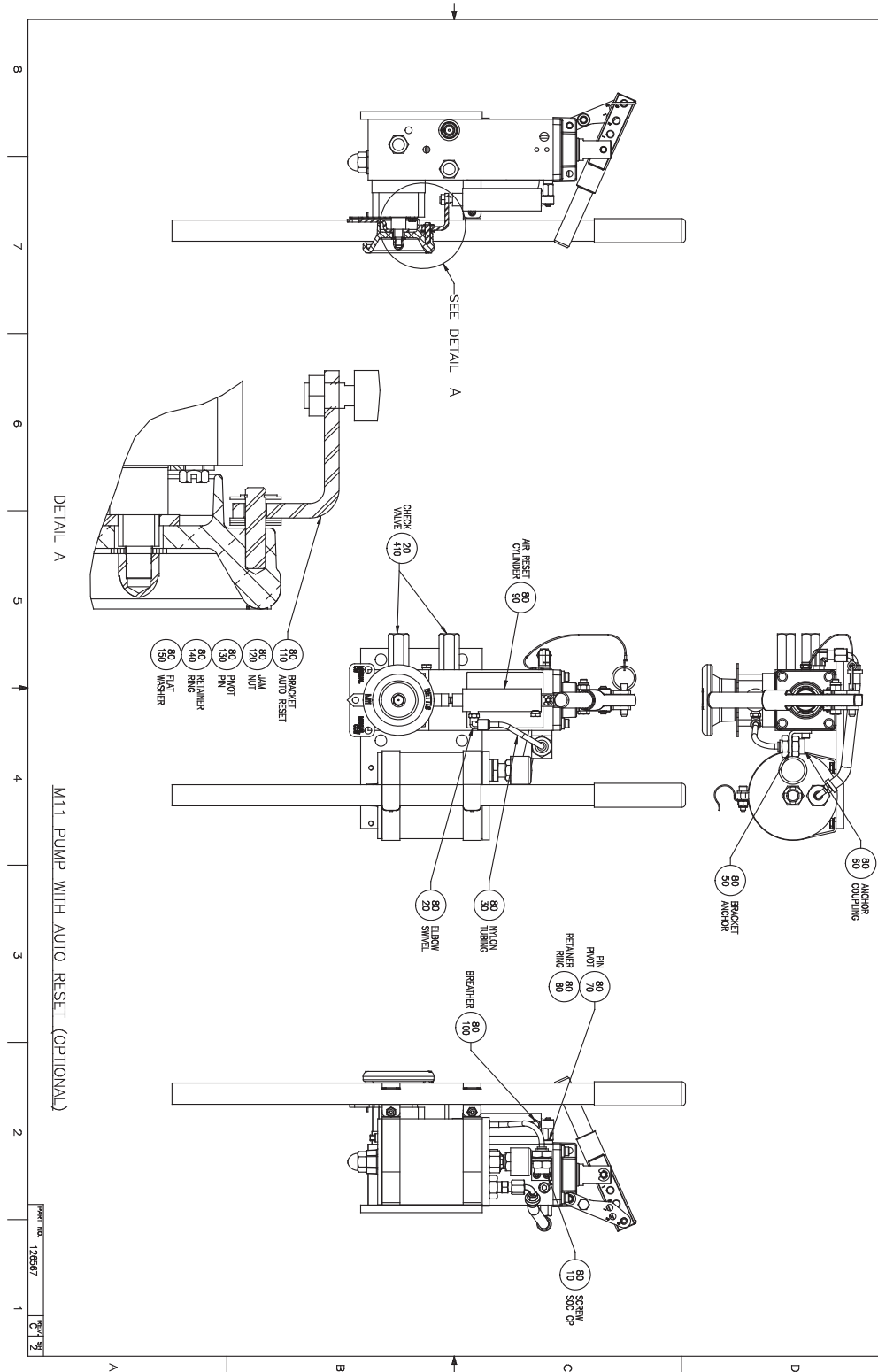

B.8 Part No. 126567, M11 Assembly Drawing, Sheet 4 of 5

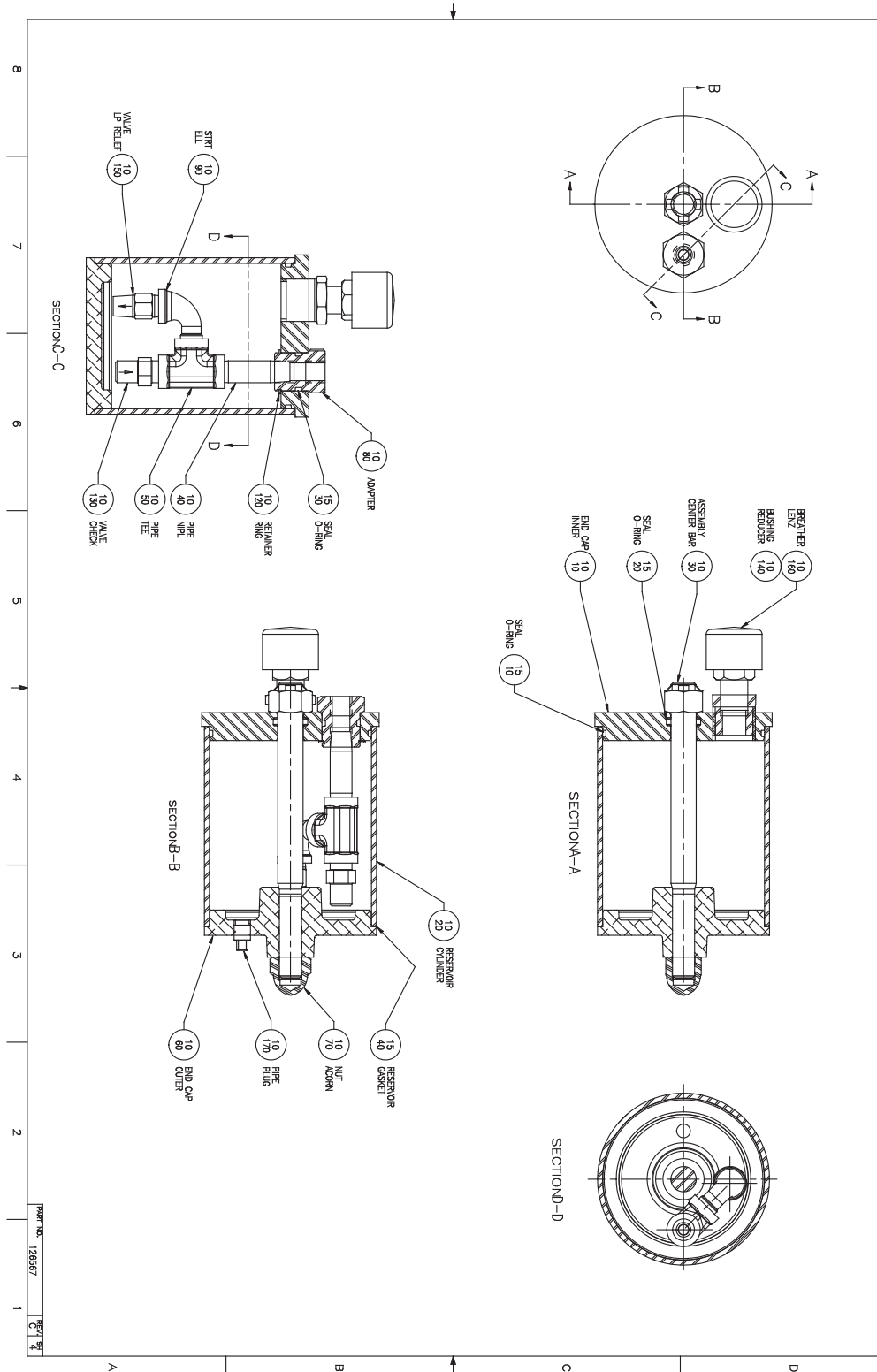

PART NO. 126567

REV. 3



B.9 Part No. 126567, M11 Assembly Drawing, Sheet 5 of 5

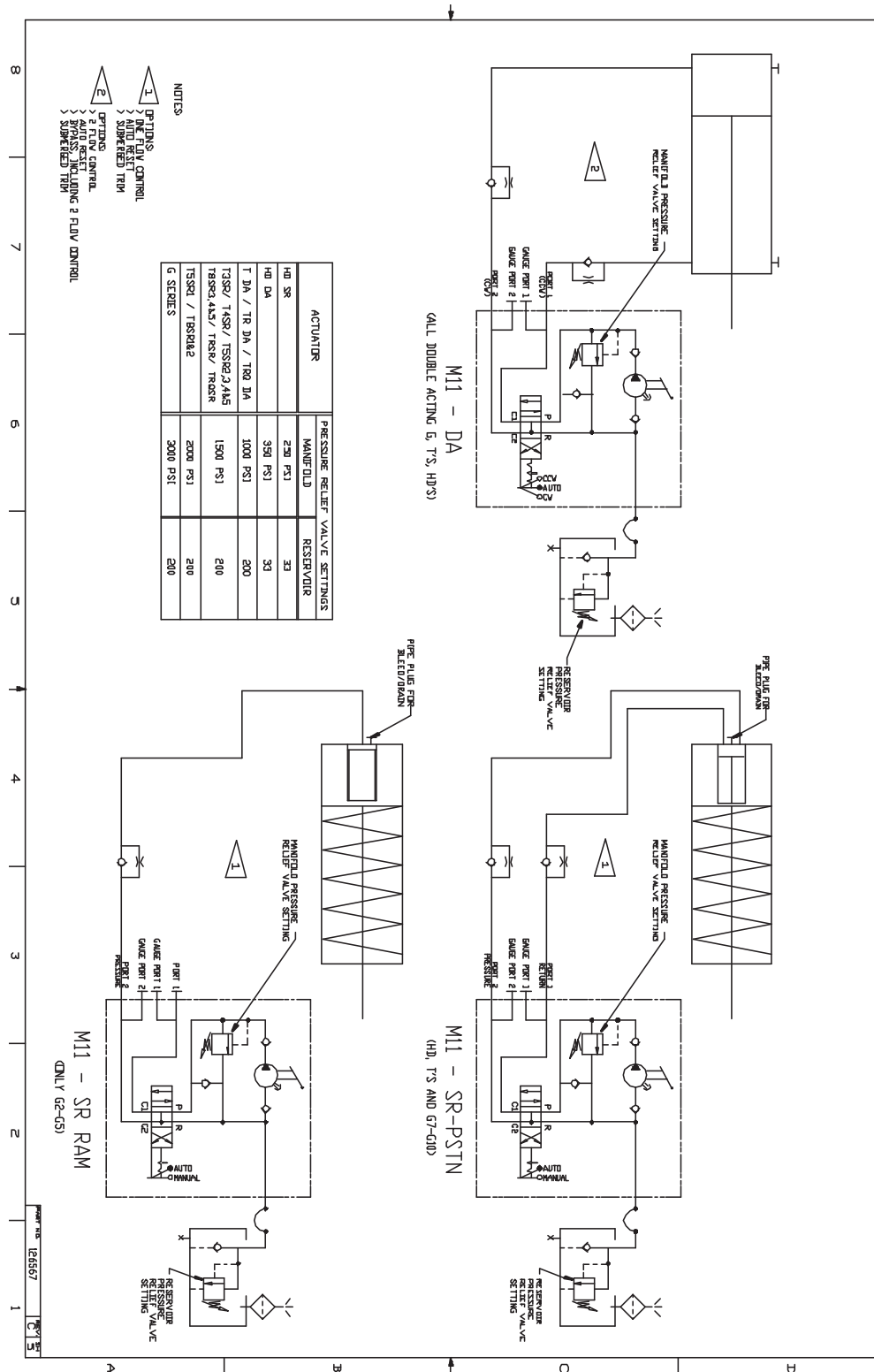

B.11 Part No. 121107, Remote Mount Assembly Drawing, M11S-S G4/G8 for Fire Safe, Sheet 2 of 2

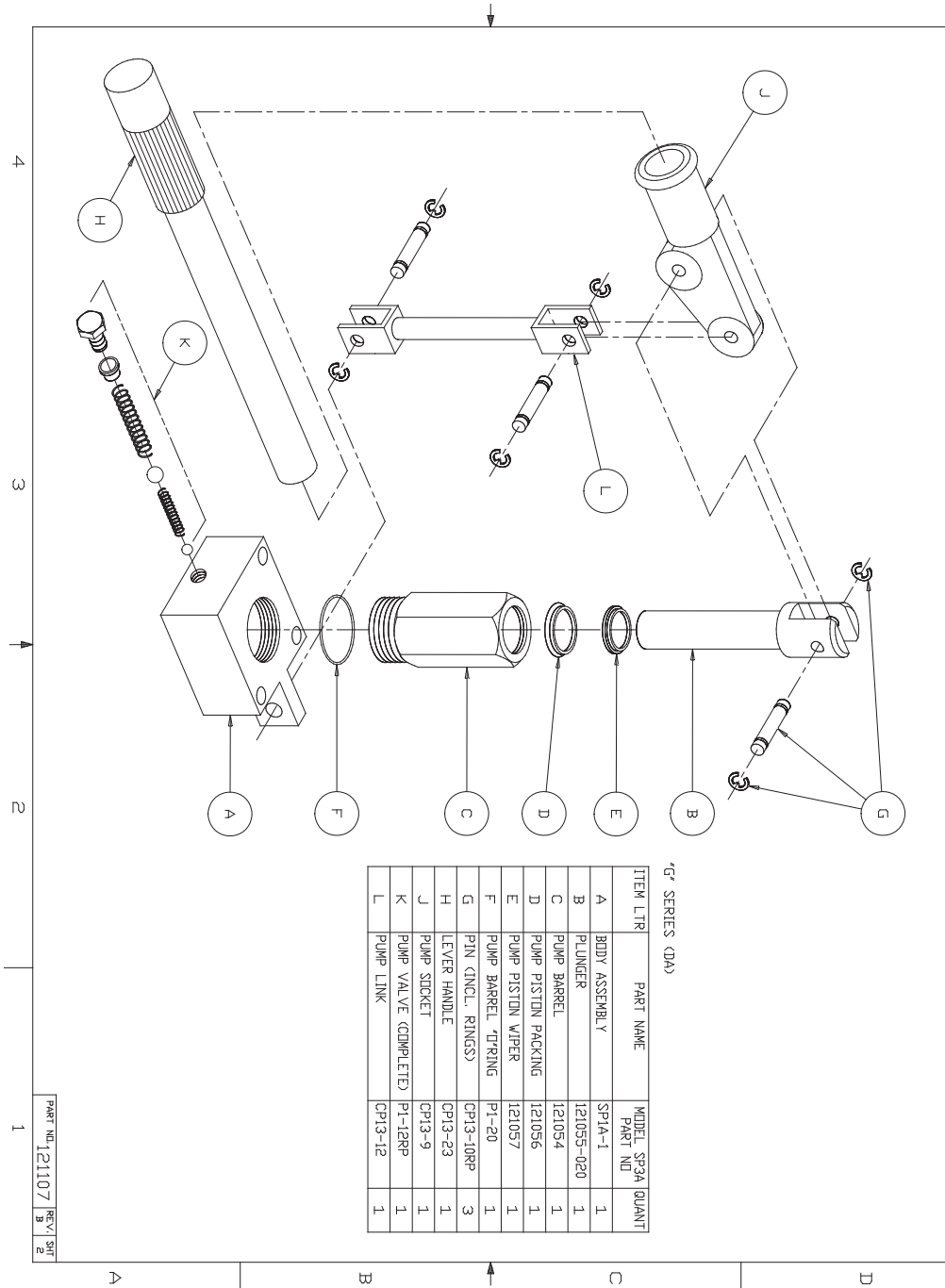

Distributed by | Distribuido por :



ANYTHING
≈ FLOWS ≈

INFO@ANYTHINGFLOWS.COM

WWW.ANYTHINGFLOWS.COM

Flow Control , our passion ®

Life Flows on ™

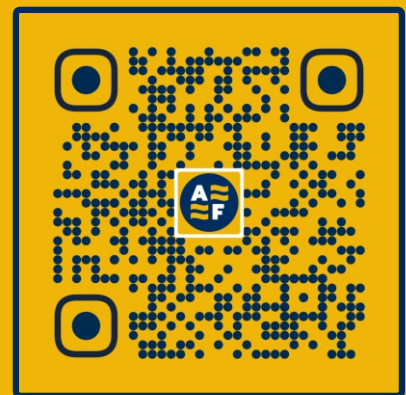

SCAN ME