



## ***Limitorque™ LPS***

Limitorque Pneumatic Scotch Yoke Heavy-Duty Actuator



*Experience In Motion*



## Quality, Dependability and Productivity

*Flowserve Limitorque makes valve control easier in ways as diverse as the applications in which its products are used. LPS pneumatic actuators deliver up to 250 kNm\* (184 000 ft-lb) of precisely controlled torque — safely automating valves for all types of applications, including HIPPS (High-Integrity Pressure Protection Systems).*

Available in a wide range of materials suitable for use in the most demanding conditions, LPS actuators are complemented by a comprehensive range of control systems, including ESD, PST, Line-Break and Quick-Closing options. A suite of standard controls systems is available for short delivery, but the Limitorque engineering team can design custom solutions for the largest and most complex customer requirements.

Today's industry requirements are more rigorous than ever before. Nowhere is this more evident than in the Oil and Gas industry where new requirements are incorporated into project specifications almost every day. Limitorque has addressed these demanding requirements in the design of their latest product, the LPS actuator. This makes the LPS the most technically advanced and market-compliant actuator available anywhere in the world.

The LPS actuator features a 25-year design life depending on service conditions, proper installation, operation and maintenance. In order to achieve this industry-leading design life, in-field maintenance is prescribed to be performed every six years of operation. For high-cycle applications, such as control valve operation, more frequent maintenance of the replaceable wear surfaces, as outlined in EN 15714, may be required.

To complete the automation package, LPS actuators are available with accessories such as lockout modules and gear overrides. Limitorque provides engineering design services for mounting hardware, ensuring that your actuation solution is ready to handle the toughest challenges.



\* For higher torque ranges, consult factory.

## LPS Limitorque Pneumatic Heavy-Duty Scotch Yoke Actuators

LPS actuators provide up to 250 kNm (184 000 ft-lb) of heavy-duty torque. Enhanced performance is achieved by using a superior scotch yoke support design that significantly reduces transverse loads. LPS actuators feature modular construction to minimize repair time and initial cost while maximizing process availability.

### Features

- Spring Return Single Acting (Fail Close CW and Fail Open CCW) and Double Acting (Fail Last / Fail As Is) executions
- True modular design for flexible and easy field conversion from Fail Close CW to Fail Open CCW configuration or vice versa
- Scotch yoke housing design optimized to facilitate field maintenance and to provide extended design life
- Symmetrical and canted scotch yoke types to perfectly fit valve torque requirement
- Fabricated carbon steel scotch yoke housing, pneumatic cylinder and spring can, providing the most rugged actuator available; different materials of construction for polar or offshore applications upon request
- ENP Lined Cylinders with Chrome Plated Piston Rod; Stainless Steel Cylinders, Tie Rods and Spool Pieces available upon request
- Increased maximum valve stem acceptability to allow direct coupling with valves
- Suitable for use in on/off, modulating and control valve application in general service, protective service and safety applications such as ESD or HIPPS
- Full range of accessories: switchboxes, positioners; ESD and PST functionalities; custom control panels; fire protection; quick exhaust and dampers; manual and hydraulic overrides

### Specifications

- Available in standard single-acting spring return and double-acting configurations, in torque ranges up to 250 kNm (184 000 ft-lb); contact factory for larger sizes
- Maximum allowable working pressure (MAWP): 12 barg (174 PSIG)
- Suitable supply medium: instrument air, nitrogen or sweet gas; contact factory for sour gas applications
- -29°C to 100°C (-20°F to 212°F) standard operating temperature range; Low temperature -60°C (-76°F) and high temperature 160°C (320°F) ranges available upon request (polar, cold, arid and tropical temperature requirements in accordance with IEC 60721)
- End mounted adjustable travel stops  $\pm 5^\circ$ , available also in an enclosed protected version upon request

### Key Certifications and Standards Compliance

- Certified according to ATEX 94/9/EC Ex II 2GD c IIC T6
- IP66/IP66M and IP67/IP67M configurations per EN 60529
- SIL 3 certified in accordance with IEC 61508
- Available in compliance with PED 97/23/EC, ASME BPVC Sec. VIII Div. 1, EN 13445-3 Part 2 for Unfired Pressure Vessels
- NEMA4 and NEMA4X per NEMA 250
- Available valve interface in compliance with ISO 5211
- Actuator spring design in compliance with EN 13906
- Corrosion protection in compliance with ISO 12944-2 and EN 15714-3; optionally available up to and including C5-M
- Available in compliance with NACE specification MR0175 for sour gas applications
- Manufactured and tested in compliance with ISO 9001 and EN 15714-3
- Available according to CU TR and GOST-R



**Double Acting with Hydraulic Override**



**Double Acting with Manual Override**



**Single Acting with Hydraulic Override**



**Single Acting with Manual Override**

## Anatomy of Limitorque LPS Actuator

The Limitorque Pneumatic Scotch Yoke (LPS) Heavy-Duty Actuator is designed to meet the industry's most recent and stringent safety and performance standards for oil and gas applications. Heavy-duty design features a robust construction with high-strength materials that deliver maximum force while minimizing localized stresses. With a maximum allowable working pressure of 12 barg (174 psig), the Scotch yoke actuator provides up to 250 kNm (184 000 ft-lb) of precisely controlled torque. The actuator is available in single-acting spring return and double-acting configurations.

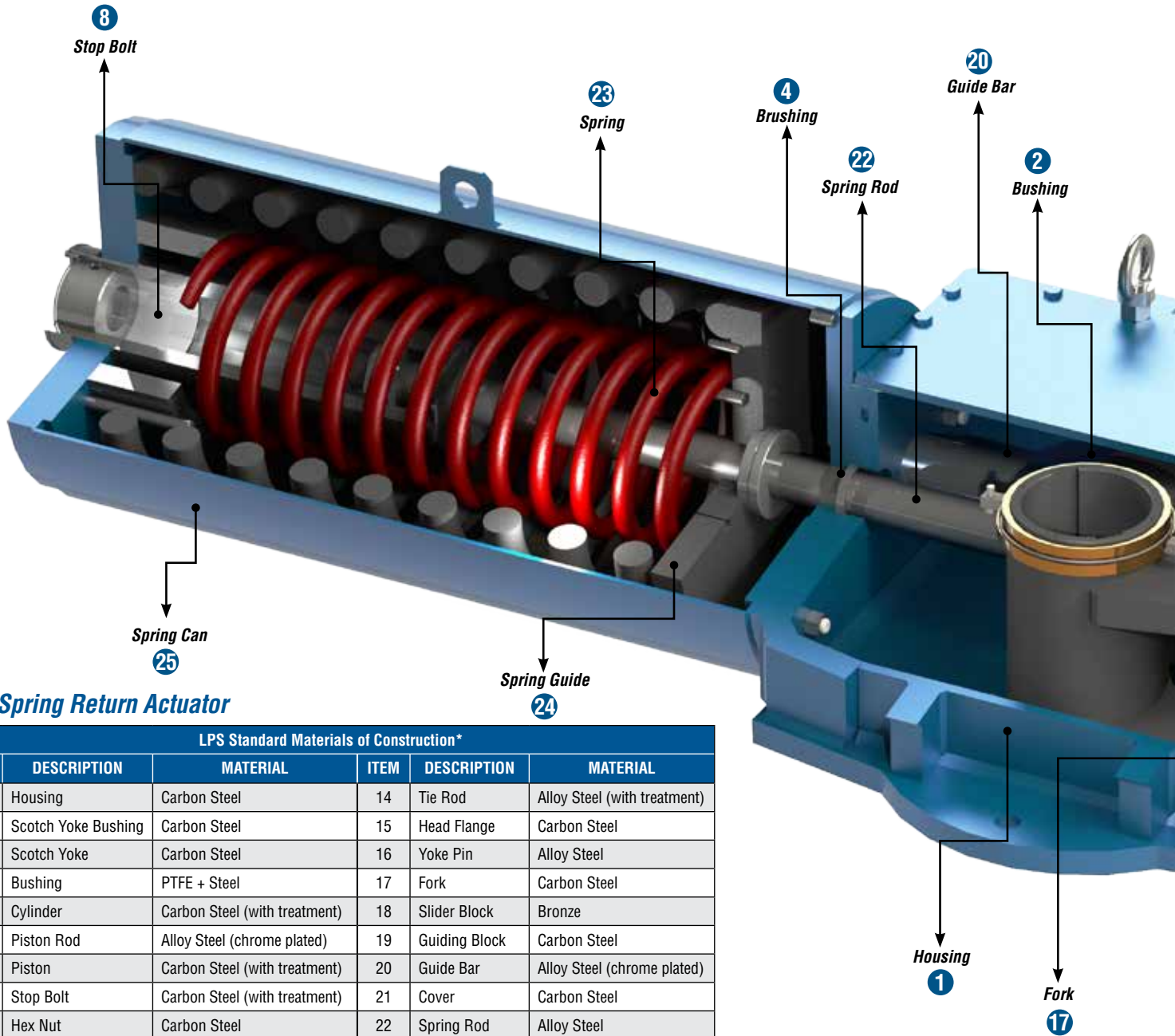

### LPS Spring Return Actuator

LPS Standard Materials of Construction*					
ITEM	DESCRIPTION	MATERIAL	ITEM	DESCRIPTION	MATERIAL
1	Housing	Carbon Steel	14	Tie Rod	Alloy Steel (with treatment)
2	Scotch Yoke Bushing	Carbon Steel	15	Head Flange	Carbon Steel
3	Scotch Yoke	Carbon Steel	16	Yoke Pin	Alloy Steel
4	Bushing	PTFE + Steel	17	Fork	Carbon Steel
5	Cylinder	Carbon Steel (with treatment)	18	Slider Block	Bronze
6	Piston Rod	Alloy Steel (chrome plated)	19	Guiding Block	Carbon Steel
7	Piston	Carbon Steel (with treatment)	20	Guide Bar	Alloy Steel (chrome plated)
8	Stop Bolt	Carbon Steel (with treatment)	21	Cover	Carbon Steel
9	Hex Nut	Carbon Steel	22	Spring Rod	Alloy Steel
10	End Flange	Carbon Steel	23	Spring	Spring Steel
11	Guide Ring	PTFE + Graphite	24	Spring Guide	Carbon Steel
12	O-Ring	NBR	25	Spring Can	Carbon Steel
13	Split Collar	Alloy Steel			

\*Special or different materials available upon request

LPS Double Acting Actuator

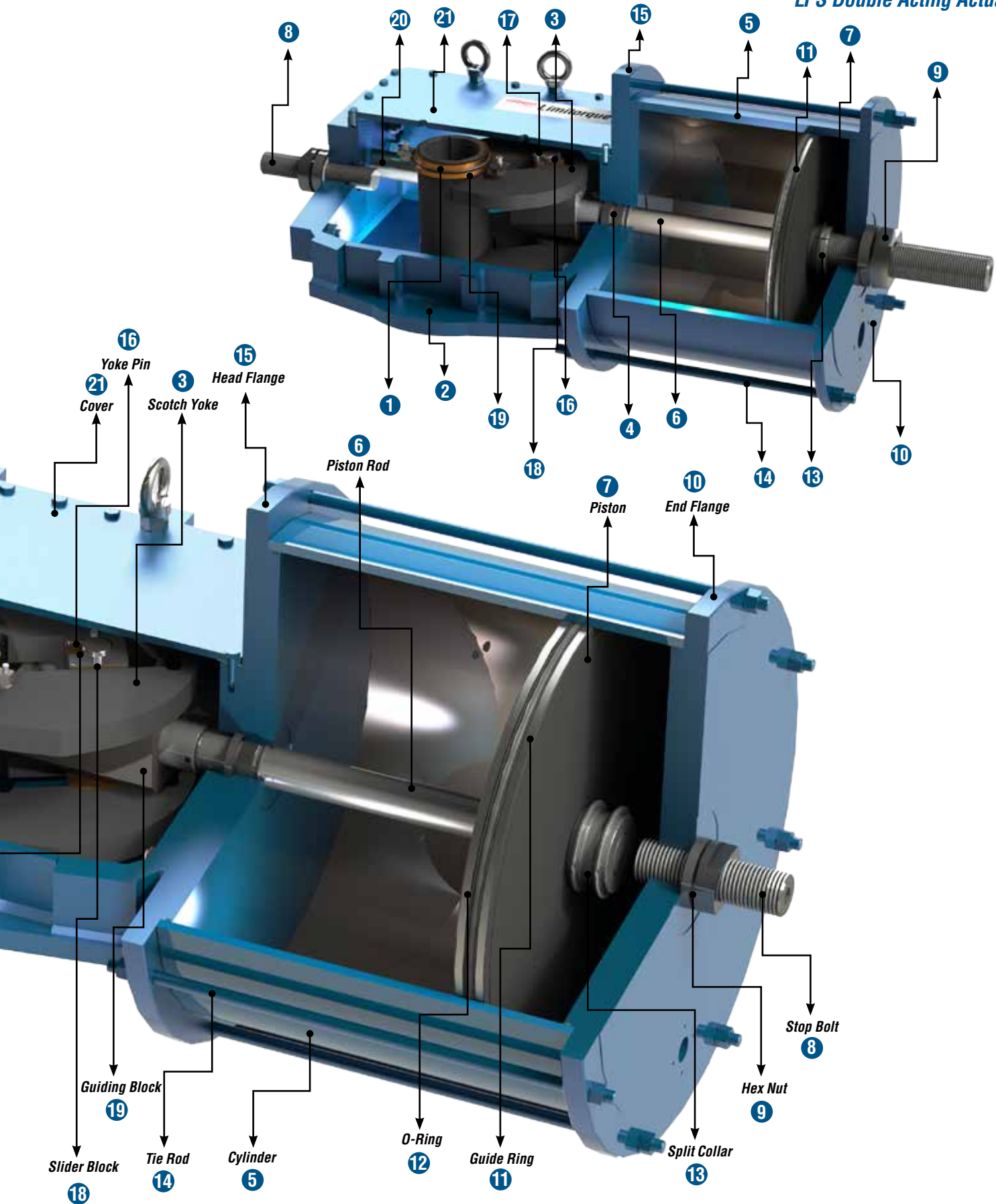

## LPS Actuator Selection Table

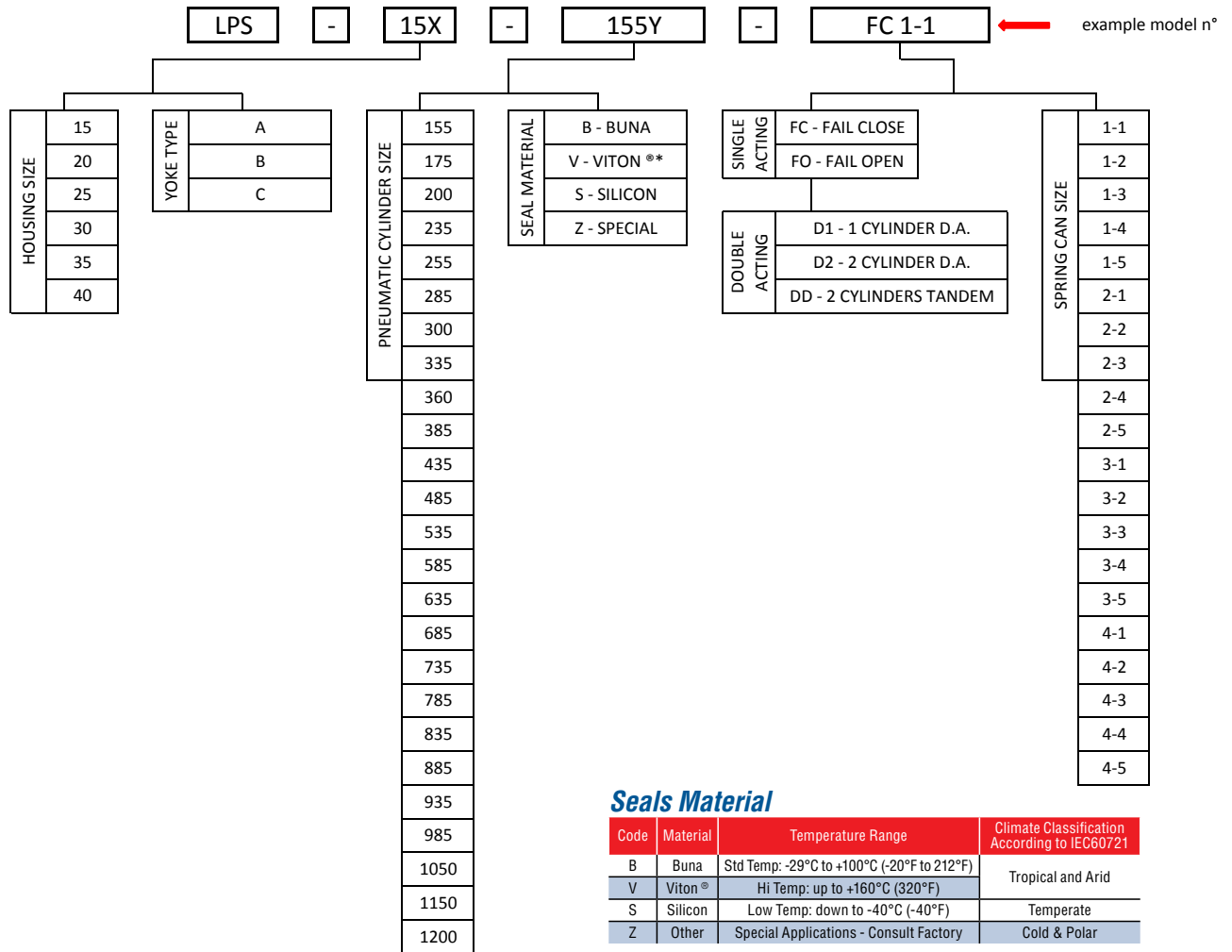

## LPS Torque and Pressure Table

Model	MOT Maximum Operating Torque Nm (ft-lb)	MOP Maximum Operating Pressure barg (PSIG)	MAWP Maximum Allowable Working Pressure barg (PSIG)
LPS-15	5500 (4057)	Variable for every cylinder size. Please refer to Technical Bulletin LFENTB0001.	12 barg (174 psig)*
LPS-20	11 000 (8113)		
LPS-25	19 000 (14 014)		
LPS-30	38 000 (28 027)		
LPS-35	70 000 (51 629)		
LPS-40	140 000 (103 259)		
LPS-45	Consult Factory	Consult Factory	
LPS-50			
LPS-55			
LPS-60			

\*Viton is a registered trademarks of E. I. du Pont de Nemours

## Control System Options

Limatorque offers a selection of standard and custom controls packages for most applications to fill customers' needs for short lead-time, low-cost solutions.

- PST
- ESD
- Quick-closing
- Modulating/CV functionality
- Quick exhaust valve with flow regulator suitable for closed loop assembly, when required
- Cylinder integral quick exhaust valve (double acting fast actuator)
- Pneumatic booster (¼ in, ½ in, 1 in size, AL and 316 SS)
- 3/2 and 5/2 pneumatic piloted valve with manual reset and override (¼ in, ½ in, 1 in size, AL and 316 SS)
- Unidirectional and bidirectional flow regulator valve (¼ in, ½ in, 1 in size, AL and 316 SS)
- Compact fittings to reduce pipe and control dimensions (¼ in, ½ in, 1 in size, AL and 316 SS)

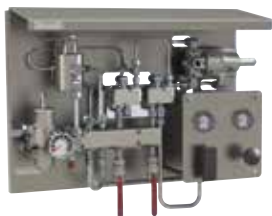

## Flowserve Solutions

In addition to providing actuators and controls designed to meet or exceed all of today's rigorous requirements, Flowserve and Limatorque lead the industry with all of the essential related solutions that our customers need to maintain peak efficiency and productivity.

- Aftermarket Parts and Services
- Business Assessments
- Actuator Inspection, Maintenance and Repair
- Engineering and Technical Services
  - Engineering Support
  - Technical Assessments
  - Equipment Performance Analysis and Upgrades
- Education and Training
  - On-site Training
  - Online Training
- Asset Data Management and Optimization Solutions

## Limatorque Additional Product Range Offering

### Electric Actuators and Controls

- MX — Non-intrusive, electronic multi-turn actuators
- QX — Non-intrusive, electronic quarter-turn actuators
- Master station, controller for redundant networked actuators
- Network controls, Modbus, Profibus DP/PA, Foundation Fieldbus, DeviceNet, HART
- L120 — Electro-mechanical, multi-turn electric actuators with integral and network controls
- SMB — Electro-mechanical, multi-turn electric actuators for nuclear and severe duty service

### Fluid Power Actuators

- Scotch yoke pneumatic actuators — LPS
- Compact Scotch yoke pneumatic actuators — LPC
- Scotch yoke hydraulic actuators — LHS
- Compact Scotch yoke hydraulic actuators — LHC\*
- Linear pneumatic actuators — LPL
- Linear hydraulic actuators — LHL
- Direct gas actuators — LDG\*
- Gas over oil actuators — LGO\*
- Electro-hydraulic actuators — LEH\*
- Standard and customized controls
- Application engineering support

### Gearboxes

- V — Bevel gearboxes for manual or motorized operation
- WG — Worm gearboxes for manual or motorized operation
- SR — Spur gearboxes for manual or motorized operation

## One Flowserve Solution

Flowserve brands for most common control accessories:

- |                       |                       |
|-----------------------|-----------------------|
| • Digital Positioners | • Valve Controllers   |
| – Logix™              | – Automax™            |
| – PMV™                | – Worcester Controls™ |
| • Analog Positioners  | • Limit Switch Boxes  |
| – PMV                 | – Worcester Controls  |
| – Accord™             | – PMV                 |
| • Diagnostic Software | – Automax             |
| – ValveSight™         | – Accord              |

\*Contact Flowserve for product availability and additional information.

Distributed by | Distribuido por :



**ANYTHING**<sup>TM</sup>  
**≈ FLOWS ≈**

[INFO@ANYTHINGFLOWS.COM](mailto:INFO@ANYTHINGFLOWS.COM)

[WWW.ANYTHINGFLOWS.COM](http://WWW.ANYTHINGFLOWS.COM)

**Flow Control , our passion ®**

**Life Flows on <sup>TM</sup>**



**SCAN ME**