

KF Valves

Series P3/M3
Trunnion Mounted
Ball Valves



Continuously Improving
Flow Control

KF Series P3/M3 Trunnion Mounted Ball Valves

Features

- Three-piece body design
- Double block and bleed
- Self relieving seat
- Double piston seat
- Trunnion supported design reduces operating torque
- Antistatic device for grounding of the ball, stem and body
- O-rings plus firesafe stem packing prevent leakage
- Corrosion resistant low friction bearings
- Inconel® seat springs provide upstream and downstream sealing
- Stainless steel sealant injection fittings for emergency stem or seal sealing
- Direct mount topworks pad for actuator or gear operator
- 6" & larger valves are equipped with lifting lugs
- Locking device (lock not included)
- Anti-blowout trunnion stem design

A large trunnion design ensures central positioning under the highest working pressure. Independent floating spring loaded seats provide a tight seal even at low differential pressures. Service and maintenance

is simplified with a bolted body design incorporating double o-rings or a combination of o-rings and gaskets, suitable for buried or above ground installation. See page 3 for complete product offering.



Contents

Assembly Part Number Codes	3
General Design Features	4
Technical Seating Features	5
Applicable Standards	6
Assembly Part Number Butt weld End Pipe Codes and Calculating Pipe Wall Thickness	7
Component Parts	8-10
Dimensional Data	11-15
Weights	16
Topworks & Stem Torque Data	17-18
Engineering Data	19
Optional Accessories and Installation	20

KF Series P3/M3 Part Number Codes

V • Domestic **M** • Global

Base Number • See Chart Below

End Connection & Seat Configuration

Self Relieving Seat Config.		Double Piston Seat Config.	
1 • RF	4 • RF x WE	F • RF	J • RF x WE
2 • RTJ	5 • RTJ x WE	G • RTJ	K • RTJ x WE
3 • WE		H • WE	

Weld End Wall Thickness

99 • No Weld End **XX** • See Weld Chart Page 7

Body / Bolting Material NACE Conformance

NACE III / Cl. III Bolting		NACE II / Cl. II Bolting	
A • CS / B7 (Black)		N • CS / B7M	
B • SS / B7 (Xylan®)		P • SS / B7M (Xylan®)	
C • LTCS / L7 (Black)		Q • SS / L7M (Xylan®)	
D • SS / L7 (Xylan®)		R • CS / B7M Cad	
E • LTCS / B7 (Black)		S • LTCS / L7M	
L • CS / B7 (Xylan®)		T • SS / 660SS	

Trim

2 • 316SS* **6** • CS w/3 mil ENP (Std. on 2" & Larger)

3 • 410SS or CA-15M **7** • LTCS (3 mil ENP)

Seat Insert

A • Devlon® **C** • HT4 (PEEK™)

Seal Material

2 • Viton® A	A • James Walker® Viton®	K • JW Elast-O-Lion® 101
4 • EPDM	F • Elast-O-Lion® 985	N • LT HNBR
5 • Aflas®	G • HNBR (Std.)	

Actuation

3 • Gear Operator **6** • Locking Gear Operator **A** • For Actuator

4 • Locking Handle **9** • Bare Stem

Process Codes

(Last two digits used ONLY when process codes are required).

Example

V 313 - 1 99 A 6 A G 4 XX

(i.e. VXXX-XXXXXXXXXX) - Domestic
(i.e. MXXX-XXXXXXXXXX) - Global

*8" Class 900 and larger 17-4PH SS (MR0175-2002)

Asterisk (*) in lieu of dash (-) in Assembly Part Number indicates customer requires source inspection. (i.e. VXXX * XXXXXXXXXXXX)

Assembly Base Numbers, 2" FP - 36" FP, Class 150, 300, 600, 900, 1500 & 2500

Class	Size (in.)															
	2FP	3RP	3FP	4RP	4FP	6RP	6FP	8RP	8FP	10RP	10FP	12RP	12FP	14RP	14FP	16RP
150	111	112	113	114	115	116	117	118	119	120	121	122	123	124	125	126
300	211	212	213	214	215	216	217	218	219	220	221	222	223	224	225	226
600	311	312	313	314	315	316	317	318	319	320	321	322	323	324	325	326
900	411	412	413	414	415	416	417	418	419	420	421	422	423	424	425	426
1500	511	512	513	514	515	516	517	518	519	520	521	522	523	524	525	526
2500	611	612	613	614	615	616	617	618	619	620	621	622	623	—	—	—

Class	Size (in.)														
	16FP	18FP	20RP	20FP	22FP	24RP	24FP	26FP	28FP	30RP	30FP	32FP	34FP	36RP	36FP
150	127	129	130	131	133	134	135	137	139	140	141	143	145	146	147
300	227	229	230	231	233	234	235	237	239	240	241	243	245	246	247
600	327	329	330	331	333	334	335	337	339	340	341	343	345	346	347
900	427	429	430	431	—	434	435	437	439	440	441	443	445	446	447
1500	527	529	530	531	—	—	535	—	—	—	—	—	—	—	—

KF Series P3/M3 Design Features

1 Anti-Blowout Stem Design

Stem seal integrity is achieved by the use of three o-rings (or two o-rings and a graphite gasket). Upper o-ring (or graphite gasket) can be replaced with the valve in line and under pressure.

2 Lubricant/Emergency Seat Seal

Special sealants may be injected through fittings that are located on the adapter flanges to restore sealing integrity if seat sealing surface is damaged. A second internal check valve provides backup to the fitting.

3 Emergency Sealant Injection System

The sealant injection system located on the bonnet can be utilized in case of emergencies, o-ring damage, or if stem leakage occurs.

4 Double Sealed Envelope Connections

Double o-rings or a combination of an o-ring and firesafe gasket on body/adaptor connections to ensure positive sealing. This makes the P3/M3 suitable for above or below ground service.

5 Heavy Duty Bearings

6" - 12" Class 900, 1500 & 2500
14" - 24" Class 150, 300 & 600

Trunnions are supported by heavy duty teflon® coated steel bearings. Thrust load on the ball is supported by large trunnions mounted within captured trunnion blocks, resulting in low operating torque and seat wear.

6 Antistatic Device

A spring between the trunnion and the ball or between the stem and the gland plate permits electrical continuity between all valve components.

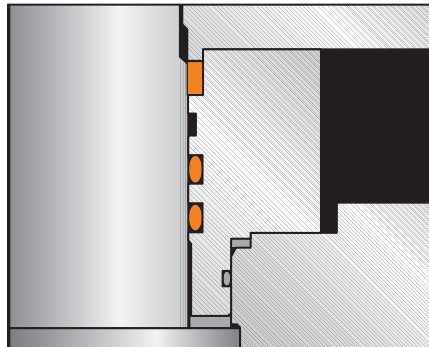

1

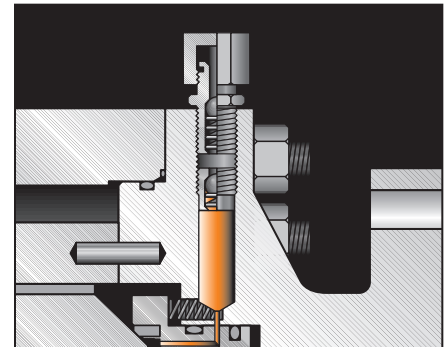

2

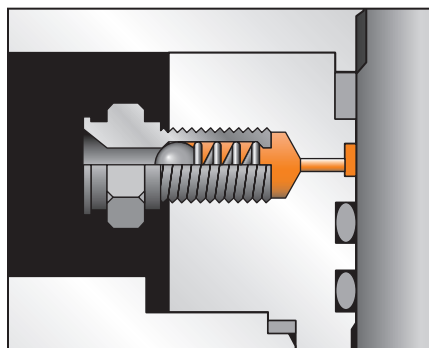

3

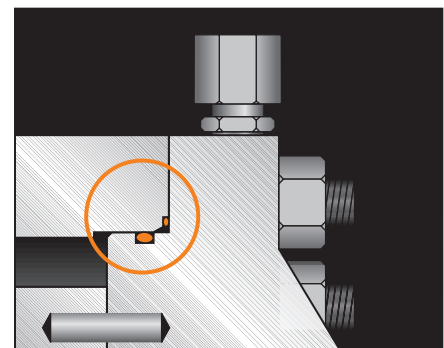

4

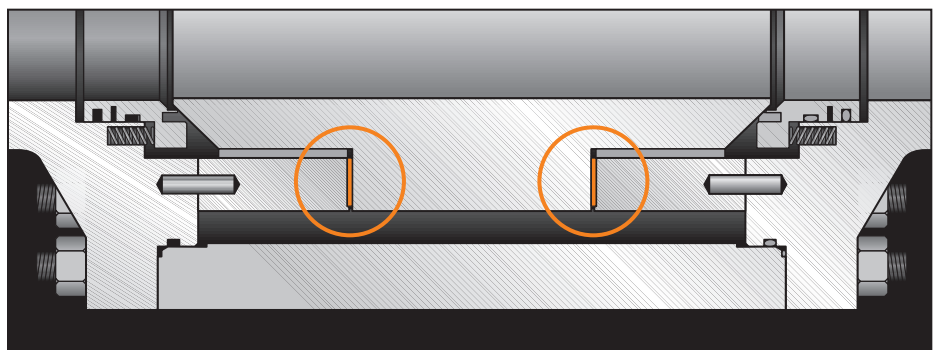

5

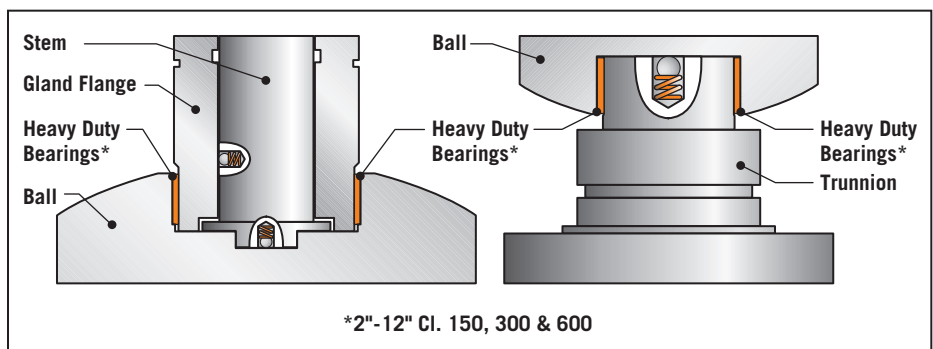

6

KF Series P3/M3 Technical Seating Features

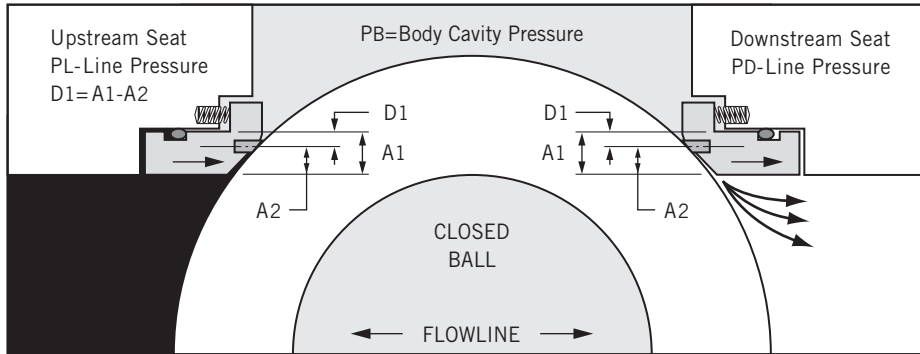

Self Relieving Seat Design

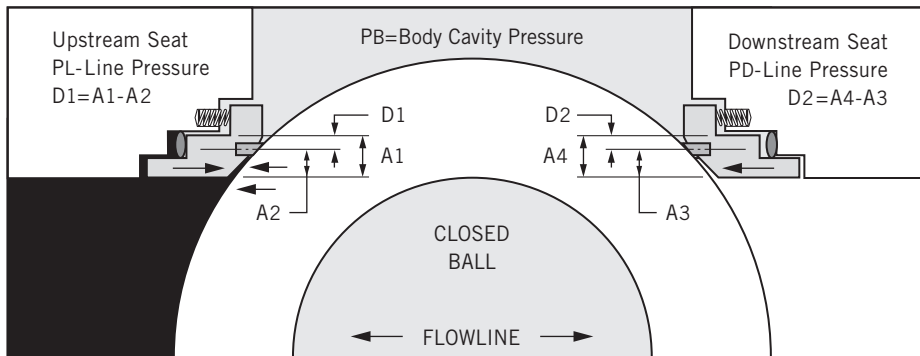

Double Piston Seat Design

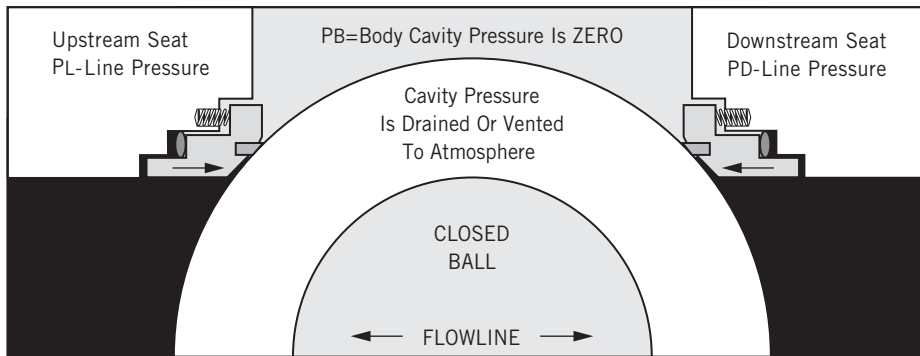

Double Block and Bleed

Double Block and Bleed

The double block and bleed condition is available in all seat design configurations. When the ball is in the closed position the body cavity pressure may be drained down to 'zero' by

opening the bleed valve and draining the fluid by removing the drain plug. Each seat works independently assuring tight shut off seal against ball on the upstream and downstream side.

Self Relieving Seat Design

Upstream Seat

The difference in the area ($D1$) times the line pressure forces the seat against the ball surface. Also the springs behind the seat adds the force to the seat which keeps the seat in contact with the ball surface by providing the tight seal.

Downstream Seat

When the body cavity pressure exceeds the spring pressure, automatic pressure relief will occur by relieving the body cavity pressure past the downstream seat. This eliminates the need for the body relief valve.

Double Piston Seat Design

Upstream Seat

Line pressure acting on the seat area ($A1$) does not equalize against the line pressure acting on the seat area ($A2$). The difference in the area ($D1$) times the line pressure creates a "piston effect" force which pushes the seat against the ball surface resulting in a tight effective seal.

Downstream Seat

When the body cavity pressure is greater than the downstream pressure, the body cavity pressure acts on the seal area ($A4$). The net pressure difference, acting over area ($D2$), pushes the downstream seat tightly against the ball creating a positive seal.

The Ultimate Benefit of Using the "Double Piston Seat" Design

In case of upstream seat leakage, the downstream seat maintains a pressure assisted tight shut off by sealing against the ball surface.

KF Series P3/M3 Applicable Standards

The following list contains the most important applicable standards for ball valves. KF valves may be designed, manufactured and tested in accordance with other international standards on request.

API-American Petroleum Institute

Spec. Q1

Spec. 6D

Specification for pipeline valves.

Std. 607

Fire test for soft seated quarter-turn valves.

Spec. 6FA

Specification for fire testing of valves.

Std. 598

Valve inspection and test.

Std. 605

Large diameter carbon steel flanges.

ASME/ANSI-American National Standard Institute

B 16.5

Steel pipe flanges and flanged fittings.

B 16.10

Face-to-face and end-to-end dimensions of ferrous valves.

B 16.25

Butt welding ends.

B 16.34

Steel valves-flanged and butt welding ends.

B 31.3

Chemical plant and petroleum refinery piping.

B 31.4

Liquid petroleum transportation piping systems.

B 31.8

Gas transmission and distribution piping systems.

ASTM-American Society for Testing Materials

Consult factory for details.

British Standards

BS 1503

Specification for steel forgings for pressure purposes.

BS 1504

Specification for steel castings for pressure purposes.

BS 2080

Face-to-face, center-to-face, end-to-end and center-to-end dimensions of flanged and butt welding end steel valves for the petroleum, petrochemical and allied industries.

ISO-International Organization for Standardization

ISO 9001:2008

Quality systems-Model for quality assurance in design / development, production, installation and servicing.

ISO 5211

Topworks mounting dimensions

ISO 15156

For use in H₂S containing environments in oil and gas production.

MSS-Manufacturers Standardization Society

SP 6

Standard finishes for contact faces of pipe flanges and connecting-end flanges of valves and fittings.

SP 25

Standard marking system for valves, fittings, flanges and unions.

SP 45

Bypass and drain connection standard.

Hydrogen Sulfide (H₂S Environments)

NACE MR0175

ISO 15156

General principles for cracking resistant materials in H₂S containing environments in oil & gas production.

CSA-Canadian Standards Association

CSA Z245.15-2009

Standard for steel valves for intended use in oil or gas pipeline systems.

CSA Z662-07

Oil and gas pipeline systems.



KF Series P3/M3 Buttweld End Pipe Code

Pipe Wall Thickness Codes for Assembly Part Number

Pipe Description	Nominal Pipe Size (in.) / KF Schedule Code													
	2	Code	3	Code	4	Code	6	Code	8	Code	10	Code	12	Code
Outside Dia. (in.)	2.375		3.500		4.500		6.625		8.625		10.750		12.750	
(STD) Standard	—	—	—	—	.237	17	.280	22	.322	28	.365	32	.375	33
Schedule 40	.154	08	.216	14	.237	17	.280	22	.322	28	.365	32	.406	35
XS	.218	15	.300	24	.337	30	.432	36	.500	39	.500	39	.500	39
Schedule 80	.218	15	.300	24	.337	30	.432	36	.500	39	.593	43	.687	48
Schedule 160	.343	31	.438	38	.531	40	.718	49	.906	55	1.125	62	1.312	68
XXS	.436	37	.600	44	.674	47	.864	53	.875	54	1.000	58	1.000	58

Pipe Description	Size (in.) / KF Schedule Code											
	14	Code	16	Code	18	Code	20	Code	22	Code	24	Code
Outside Dia. (in.)	14.000		16.000		18.000		20.000		22.000		24.000	
(STD) Standard	.375	33	.375	33	.375	33	.375	33	.375	33	.375	33
Schedule 40	.438	38	.500	39	.562	42	.593	43	—	—	.687	48
XS	.500	39	.500	39	—	—	—	—	0.500	39	—	—
Schedule 80	.750	50	.843	52	.937	56	1.031	59	1.125	62	1.218	65
Schedule 160	1.406	70	1.593	75	1.781	78	1.968	82	—	—	2.343	85
XXS	—	—	—	—	—	—	—	—	—	—	—	—

Consult factory for other wall thicknesses.

Calculating Pipe Wall Thickness

To find the “pipe wall thickness” for buttweld valves, subtract the inside diameter from the “pipe outside diameter” for the appropriate size, listed to the right. Then divide the outcome by two (2).

Example

For a 4" valve with a 3.826 inside diameter:
 Outside diameter taken from chart at right: 4.500
 Inside diameter given by customer: 3.826

$$\frac{4.500 - 3.826}{2} = .337$$

Once you have determined the “pipe wall thickness”, find that number in the chart above. The two-digit number to the left should then be used in the “pipe wall thickness” digits of the valve assembly part number. In this example that would be 30.

Pipe Outside Diameter (O.D.)

Pipe Size (in.)	Outside Dia. (in., mm)	
	in.	mm
2	2.375	60.33
3	3.500	88.90
4	4.500	114.30
6	6.625	168.28
8	8.625	219.08
10	10.750	273.05
12	12.750	323.85
14	14.000	355.60
16	16.000	406.40
18	18.000	457.20
20	20.000	508.00
24	24.000	609.60

KF Series P3₁/M3₁ Component Parts

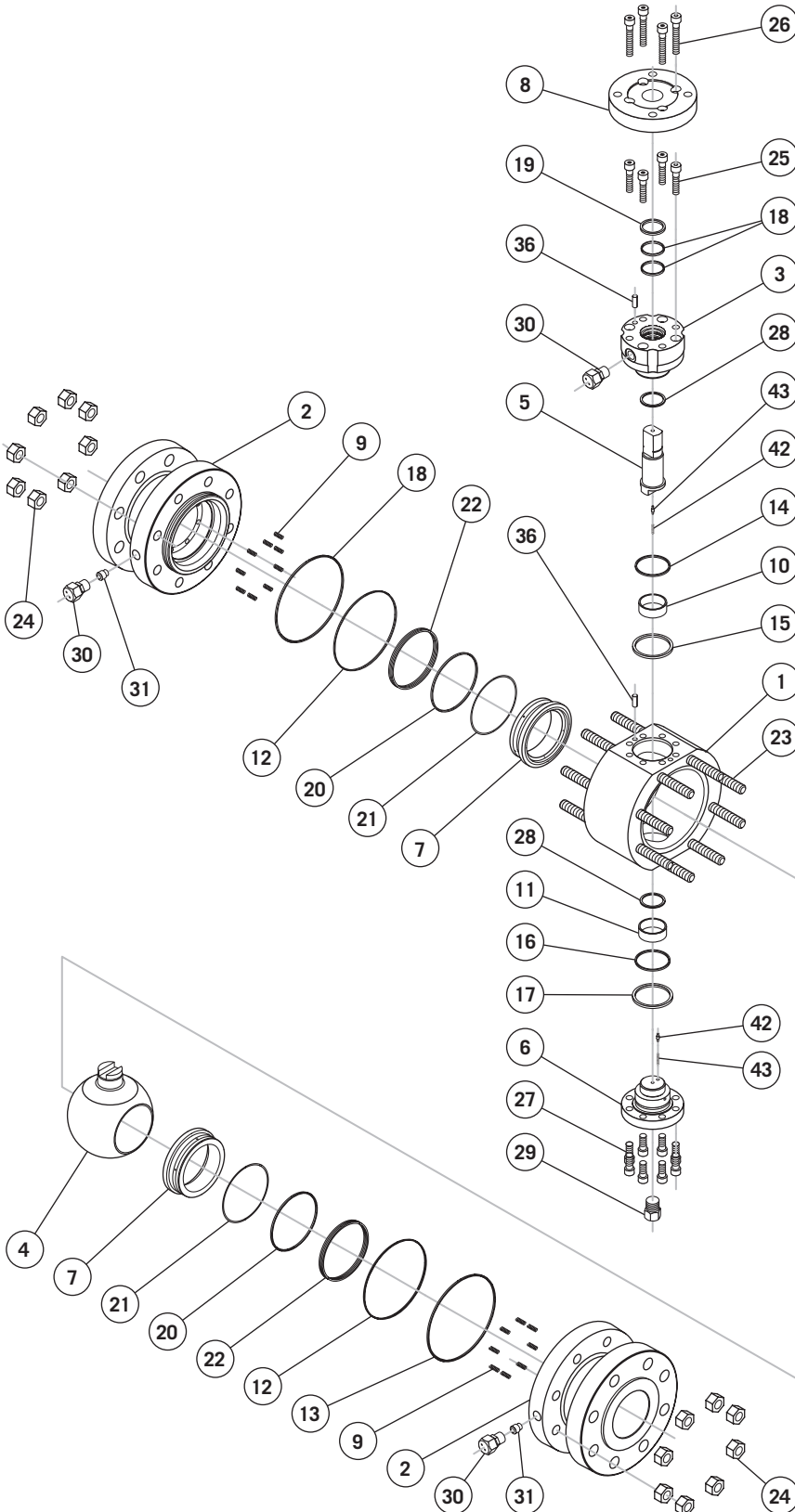

Parts List, 2", 3" & 4", Class 150, 300, 600, 900, 1500 & 2500

Part No.	Description
1	Body
2	Adapter
3	Bonnet
4	Ball
5	Stem
6	Lower Trunnion
7	Seat Assembly
8	Top Cover
9	Seat Springs
10	Stem Bearing
11	Lower Trunnion Bearing
12	Adapter Primary Seal
13	Adapter Sub Seal
14	Bonnet Primary Seal
15	Bonnet Sub Seal
16	Lower Trunnion Primary Seal
17	Lower Trunnion Sub Seal
18	Stem Seal
19	Stem Sub Seal
20	Seat Seal
21	Seat Seal Backup
22	Seat Sub Seal
23	Stud, Body
24	Nut, Body
25	Cap Screw, Bonnet
26	Cap Screw, Top Cover
27	Cap Screw, Lower Trunnion
28	Thrust Bearing
29	Bleed / Drain Valve
30	Injection Fitting
31	Ball Check
36	Alignment Pin, Bonnet
42	Antistatic Pin
43	Antistatic Spring

KF Valves

KF Series P3₂/M3₂ Component Parts

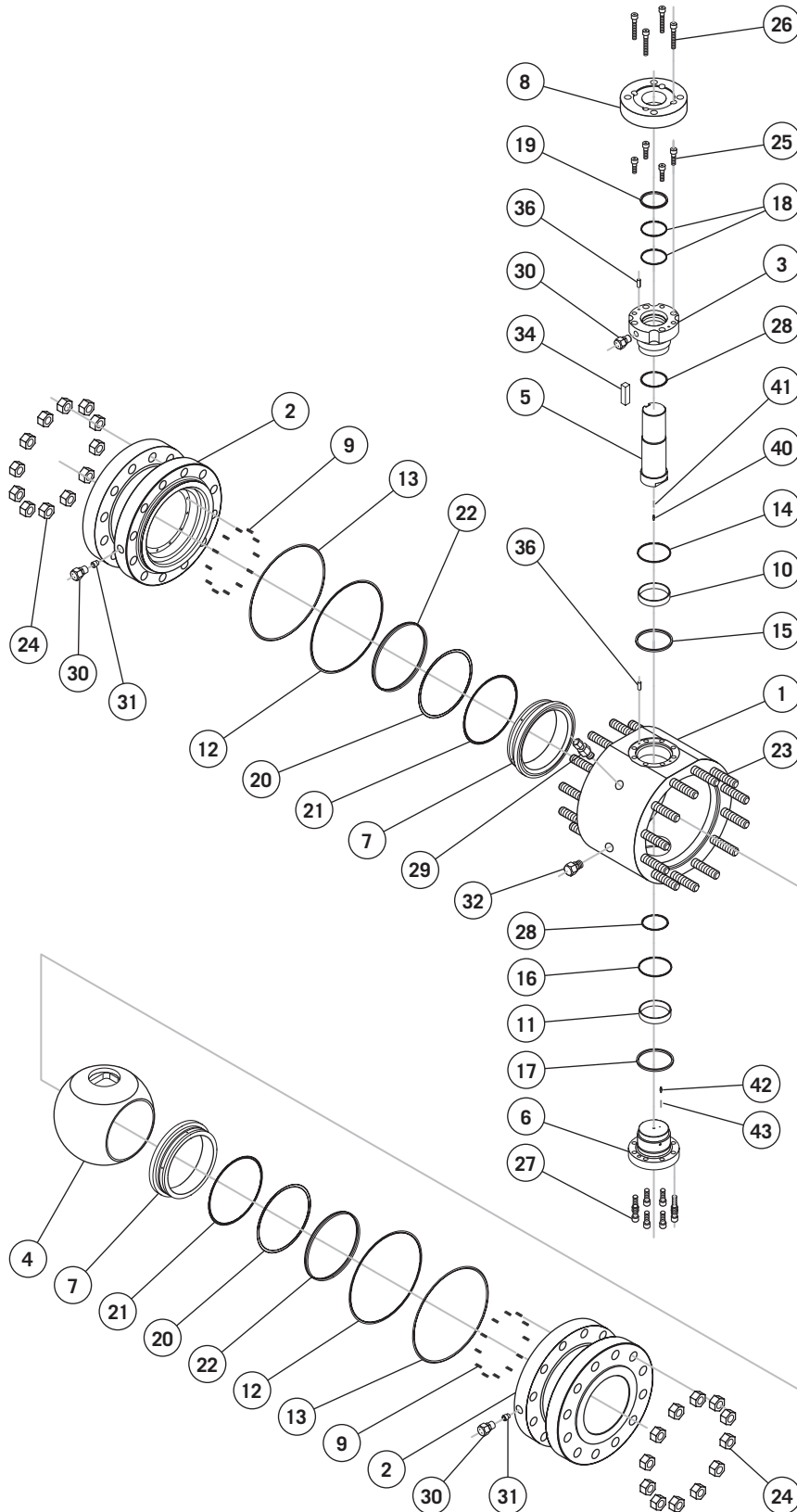

Parts List, 6"-12", Class 150, 300 & 600

Part No.	Description
1	Body
2	Adapter
3	Bonnet
4	Ball
5	Stem
6	Lower Trunnion
7	Seat Assembly
8	Top Cover
9	Seat Springs
10	Stem Bearing
11	Lower Trunnion Bearing
12	Adapter Primary Seal
13	Adapter Sub Seal
14	Bonnet Primary Seal
15	Bonnet Sub Seal
16	Lower Trunnion Primary Seal
17	Lower Trunnion Sub Seal
18	Stem Seal
19	Stem Sub Seal
20	Seat Seal
21	Seat Seal Backup
22	Seat Sub Seal
23	Stud, Body
24	Nut, Body
25	Cap Screw, Bonnet
26	Cap Screw, Top Cover
27	Cap Screw, Lower Trunnion
28	Thrust Bearing
29	Bleed/Drain Valve
30	Injection Fitting
31	Ball Check
32	Drain Plug
34	Key
36	Alignment Pin, Bonnet
42	Antistatic Pin
43	Antistatic Spring

KF Series P3₃/M3₃ Component Parts

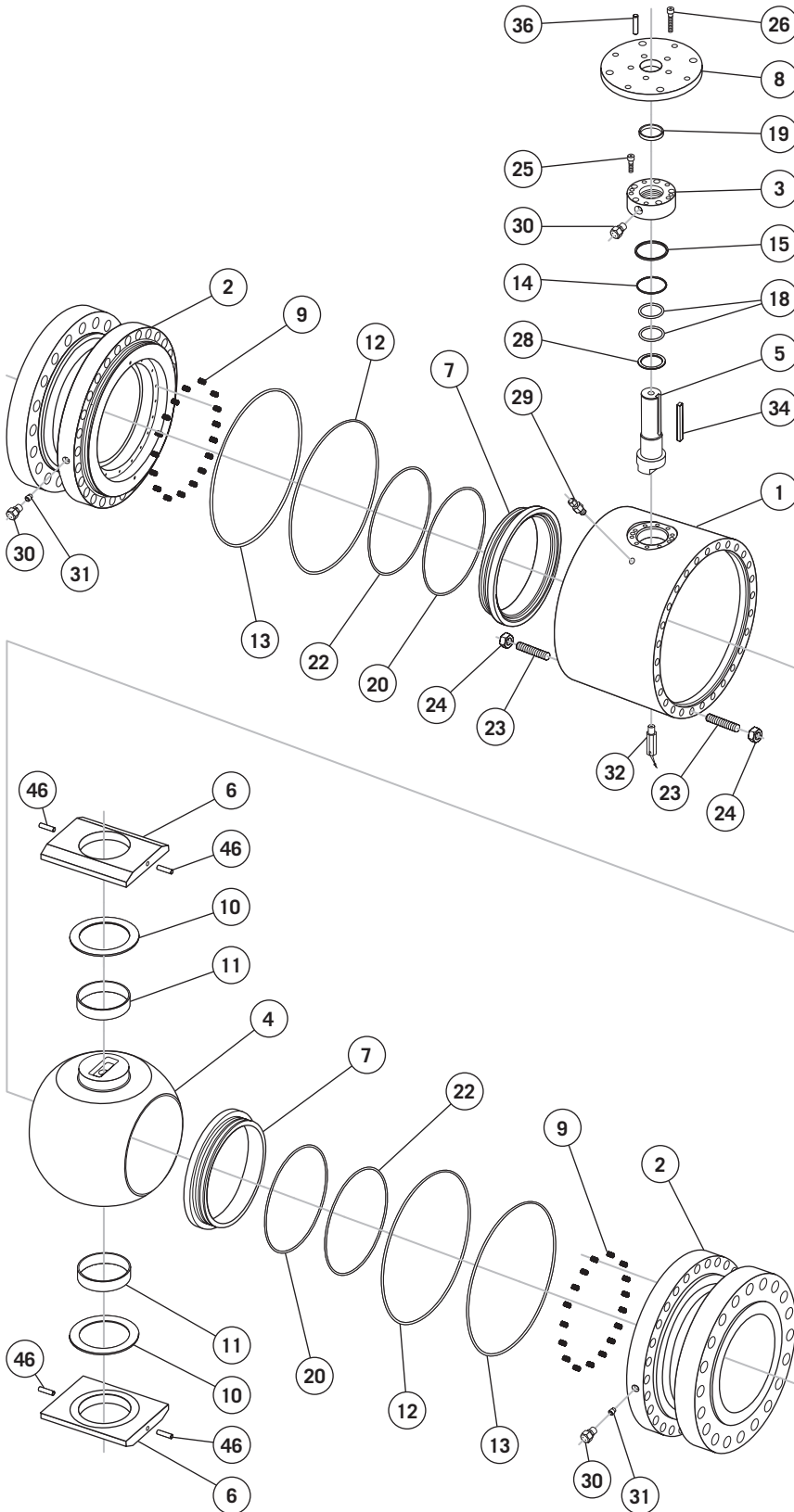

Parts List 6"-12", Class 900, 1500 & 2500 14" & Larger, All Classes

Part No.	Description
1	Body
2	Adapter
3	Bonnet
4	Ball
5	Stem
6	Trunnion Block
7	Seat Assembly
8	Top Cover
9	Seat Springs
10	Stem Bearing
11	Lower Trunnion Bearing
12	Adapter Primary Seal
13	Adapter Sub Seal
14	Bonnet Primary Seal
15	Bonnet Sub Seal
16	Lower Trunnion Primary Seal
17	Lower Trunnion Sub Seal
18	Stem Seal
19	Stem Sub Seal
20	Seat Seal
21	Seat Seal Backup
22	Seat Sub Seal
23	Stud, Body
24	Nut, Body
25	Cap Screw, Bonnet
26	Cap Screw, Top Cover
28	Thrust Bearing
29	Bleed / Drain Valve
30	Injection Fitting
31	Ball Check
32	Drain Plug
34	Key
36	Alignment Pin, Bonnet
46	Trunnion Block Pin

KF Valves

KF Series P3/M3 Dimensional Data

Dimensional Data (in., mm), 2"FP-24"FP, Class 150

Size (in.)	Dimension (in.)											
	A/RF	A/RTJ	A/WE	B	B1	C	D	E	F	G	H	I
2	7.0	7.5	8.5	2.0	2.0	6.0	4.3	4.9	5.9	8.1	—	—
3 x 2	8.0	8.5	11.1	2.0	3.0	7.5	4.3	4.9	5.9	8.1	—	—
3	8.0	8.5	11.1	3.0	3.0	7.5	6.0	5.0	7.2	15.0	—	—
4 x 3	9.0	9.5	12.0	3.0	4.0	9.0	6.0	5.0	7.2	15.0	—	—
4	9.0	9.5	12.0	4.0	4.0	9.0	7.5	6.5	10.4	9.4	9.1	7.9
6 x 4	15.5	16.0	18.0	4.0	6.0	11.0	7.5	6.5	10.4	9.4	9.1	7.9
6	15.5	16.0	18.0	6.0	6.0	11.0	9.1	9.2	12.6	10.6	12.9	15.7
8 x 6	18.0	18.5	20.5	6.0	8.0	13.5	9.1	9.2	12.6	10.6	12.9	15.7
8	18.0	18.5	20.5	8.0	8.0	13.5	11.4	12.7	16.3	13.5	12.6	15.7
10 x 8	21.0	21.5	22.0	8.0	10.0	16.0	11.4	12.7	16.3	13.5	12.6	15.7
10	21.0	21.5	22.0	10.0	10.0	16.0	12.6	14.6	19.7	15.1	14.2	19.7
12 x 10	24.0	24.5	25.0	10.0	12.0	19.0	12.6	14.6	19.7	15.1	14.2	19.7
12	24.0	24.5	25.0	12.0	12.0	19.0	15.1	17.1	23.2	17.6	16.5	23.6
14 x 12	27.0	27.5	30.0	12.0	13.3	21.0	15.1	17.1	23.2	17.6	16.5	23.6
16 x 12	30.0	30.5	33.0	12.0	15.3	23.5	15.1	17.1	23.2	17.6	16.5	23.6
14	27.0	27.5	30.0	13.3	13.3	21.0	15.7	15.3	25.1	18.5	20.4	27.6
16	30.0	30.5	33.0	15.3	15.3	23.5	16.7	17.7	28.0	19.4	18.7	27.6
20 x 16	36.0	36.5	39.0	15.3	19.3	27.5	16.7	17.7	28.0	19.4	18.7	27.6
18	34.0	34.5	36.0	17.2	17.2	25.0	19.1	19.5	31.9	22.3	22.6	27.6
20	36.0	36.5	39.0	19.3	19.3	27.5	21.1	21.4	34.1	24.3	22.6	27.6
24 x 20	42.0	42.5	45.0	19.3	23.3	32.0	21.1	21.4	34.1	24.3	22.6	27.6
24	42.0	42.5	45.0	23.3	23.3	32.0	24.3	23.2	40.4	27.8	23.3	31.5
Dimension (mm)												
2	178	190	216	51	50	152.4	108	124	150	216	—	—
3 x 2	203	216	283	51	76.2	190.5	108	124	150	216	—	—
3	203	216	283	76.2	76.2	190.5	152.5	146	184	381	—	—
4 x 3	229	241	305	76.2	101.6	228.6	152.5	146	184	381	—	—
4	229	241	305	101.6	101.6	228.6	190	164	265	239	230	200
6 x 4	394	406	457	101.6	152.4	279.4	190	164	265	239	230	200
6	394	406	457	152.4	152.4	279.4	230	234.5	319	268.5	327	400
8 x 6	457	470	521	152.4	203.2	342.9	230	234.5	319	268.5	327	400
8	457	470	521	203	203.2	342.9	289	323	415	344	321	400
10 x 8	533	546	559	203	254	406.4	289	323	415	344	321	400
10	533	546	559	254	254	406.4	320	370	500	384	360	500
12 x 10	610	622	635	254	304.8	482.6	320	370	500	384	360	500
12	610	622	635	304.8	304.8	482.6	383.8	435	590	447.7	418	600
14 x 12	686	698	762	304.8	337	533.4	383.8	435	590	447.7	418	600
16 x 12	762	775	838	304.8	387	596.9	383.8	435	590	447.7	418	600
14	686	698	762	337	337	533.4	400	388	638	470	518	700
16	762	775	838	387.4	387	596.9	423	450	710	493	475	700
20 x 16	914	927	991	387.4	489	698.5	423	450	710	493	475	700
18	864	876	914	438	438	635	485	495	810	566	575	700
20	914	927	991	489	489	698.5	537	542.5	865	618	575	700
24 x 20	1067	1080	1143	489	591	812.8	537	542.5	865	618	575	700
24	1067	1080	1143	591	591	812.8	616	590.5	1025	705	592	800

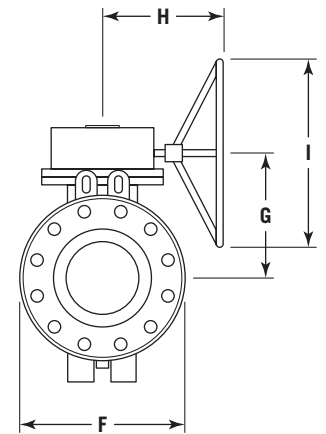
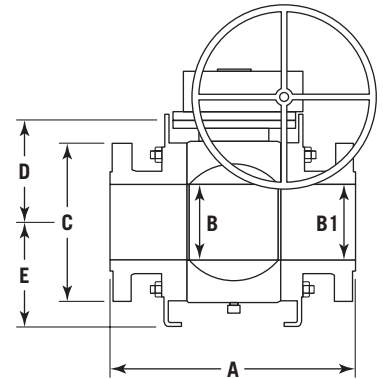

KF Series P3/M3 Dimensional Data

Dimensional Data (in., mm), 2"FP-24"FP, Class 300

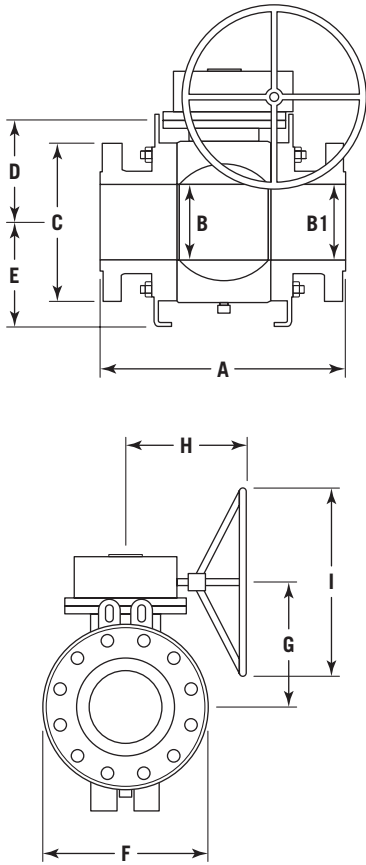

Size (in.)	Dimension (in.)											
	A/RF	A/RTJ	A/WE	B	B1	C	D	E	F	G	H	I
2	8.5	9.1	8.5	2.0	2.0	6.5	4.3	4.9	5.0	8.5	—	—
3 x 2	11.1	11.8	11.1	2.0	3.0	8.3	4.3	4.9	5.0	8.5	—	—
3	11.1	11.8	11.1	3.0	3.0	8.3	6.0	5.8	7.2	15.0	—	—
4 x 3	12.0	12.6	12.0	3.0	4.0	10.0	6.0	5.8	7.2	15.0	—	—
4	12.0	12.6	12.0	4.0	4.0	10.0	7.5	6.5	10.4	9.4	9.1	7.9
6 x 4	15.9	16.5	18.0	4.0	6.0	12.5	7.5	6.5	10.4	9.4	9.1	7.9
6	15.9	16.5	18.0	6.0	6.0	12.5	9.1	9.8	12.6	10.6	12.9	15.7
8 x 6	19.8	20.4	20.5	6.0	8.0	15.0	9.1	9.8	12.6	10.6	12.9	15.7
8	19.8	20.4	20.5	8.0	8.0	15.0	11.4	12.7	16.3	13.5	14.2	19.7
10 x 8	22.4	23.0	22.0	8.0	10.0	17.5	11.4	12.7	16.3	13.5	14.2	19.7
10	22.4	23.0	22.0	10.0	10.0	17.5	12.7	14.7	19.9	15.2	14.2	19.7
12 x 10	25.5	26.1	25.0	10.0	12.0	20.5	12.7	14.7	19.9	15.2	14.2	19.7
12	25.5	26.1	25.0	12.0	12.0	20.5	15.6	18.5	24.2	18.1	16.5	23.6
14 x 12	30.0	30.6	30.0	12.0	13.3	23.0	15.6	18.5	24.2	18.1	16.5	23.6
16 x 12	33.0	33.6	33.0	12.0	15.3	25.5	15.6	18.5	24.2	18.1	16.5	23.6
14	30.0	30.6	30.0	13.3	13.3	23.0	15.7	15.3	25.1	18.5	20.4	23.6
16	33.0	33.6	33.0	15.3	15.3	25.5	16.7	16.6	28.0	19.4	22.6	27.8
20 x 16	39.0	39.8	39.0	15.3	19.3	30.5	16.7	16.6	28.0	19.4	22.6	27.8
18	36.0	36.6	36.0	17.2	17.2	28.0	19.2	19.6	32.3	22.4	22.6	27.6
20	39.0	39.8	39.0	19.3	19.3	30.5	21.2	21.6	34.4	24.7	23.3	31.5
24 x 20	45.0	43.9	45.0	19.3	26.3	36.0	21.2	21.6	34.4	24.7	23.3	31.5
24	45.0	43.9	45.0	23.3	26.3	36.0	24.6	23.4	40.9	29.3	27.3	31.5
	Dimension (mm)											
2	216	232	216	51	50.8	165	108	124	126	216	—	—
3 x 2	283	298	283	51	76.2	210	108	124	126	216	—	—
3	283	298	283	76.2	76.2	210	152.5	146	184	381	—	—
4 x 3	305	321	305	76.2	101.6	254	152.5	146	184	381	—	—
4	305	321	305	101.6	101.6	254	190	164	265	239	230	200
6 x 4	403	419	457	101.6	152.4	318	190	164	265	239	230	200
6	403	419	457	152.4	152.4	318	230	250	319	268.5	327	400
8 x 6	501.6	517	521	152.4	203.2	381	230	250	319	268.5	327	400
8	501.6	517	521	203	203.2	381	289	323	415	344	360	500
10 x 8	568	584	559	203	254	445	289	323	415	344	360	500
10	568	584	559	254	254	445	323	373	505	387	360	500
12 x 10	648	664	635	254	304.8	520.7	323	373	505	387	360	500
12	648	664	635	304.8	304.8	520.7	396.7	470	615	460	418	600
14 x 12	762	778	762	304.8	337	584	396.7	470	615	460	418	600
16 x 12	838	854	838	304.8	387.4	648	396.7	470	615	460	418	600
14	762	778	762	337	337	584	400	388	638	470	518	600
16	738	854	838	387.4	387.4	648	423	422.3	710	493	575	705
20 x 16	991	991	1010	387.4	489	775	423	422.3	710	493	575	705
18	914	914	930	438	438	711	488	498	820	569	575	700
20	991	991	1010	489	489	775	538	549	874	627	592	800
24 x 20	1143	1143	1165	489	591	914	538	549	874	627	592	800
24	1143	1143	1165	591	591	914	624	593.8	1040	744	693	800

KF Series P3/M3 Dimensional Data

Dimensional Data (in., mm), 2"FP-36"FP, Class 600

Size (in.)	Dimension (in.)											
	A/RF	A/RTJ	A/WE	B	B1	C	D	E	F	G	H	I
2	11.5	11.6	11.5	2.0	2.0	6.5	6.1	4.2	6.5	22.8	—	—
3 x 2	14.0	14.1	14.0	2.0	3.0	8.3	6.1	4.2	6.5	22.8	—	—
3	14.0	14.1	14.0	3.0	3.0	8.3	6.7	5.4	9.0	27.6	—	—
4 x 3	17.0	17.1	17.0	3.0	4.0	10.7	6.7	5.4	9.0	27.6	—	—
4	17.0	17.1	17.0	4.1	4.1	10.8	8.0	6.4	10.4	27.8	—	—
6 x 4	22.0	22.1	22.0	4.1	6.0	14.0	8.0	6.4	10.4	27.8	—	—
6	22.0	22.1	22.0	6.0	6.0	14.0	9.1	9.2	12.6	11.2	14.2	19.7
8 x 6	26.0	26.1	26.0	6.0	8.0	16.5	9.1	9.2	12.6	11.2	14.2	19.7
8	26.0	26.1	26.0	8.0	8.0	16.5	11.4	12.4	17.0	13.5	15.0	23.6
10 x 8	31.0	31.1	31.0	8.0	10.0	20.0	11.4	12.4	17.0	13.5	15.0	23.6
10	31.0	31.1	31.0	10.0	10.0	20.0	13.0	15.7	20.4	15.5	16.5	23.6
12 x 10	33.0	33.1	33.0	10.0	12.0	22.0	13.0	15.7	20.4	15.5	16.5	23.6
12	33.0	33.1	33.0	12.0	12.0	22.0	15.9	17.8	24.5	18.7	21.5	27.6
14 x 12	35.0	35.1	35.0	12.0	13.3	23.7	15.9	17.8	24.5	18.7	21.5	27.6
16 x 12	39.0	39.1	39.0	12.0	15.3	27.0	15.9	17.8	24.5	18.7	21.5	27.6
14	35.0	35.1	35.0	13.3	13.3	23.7	15.7	15.3	25.1	18.9	23.1	31.5
16	39.0	39.1	39.0	15.3	15.3	27.0	17.4	17.6	28.9	20.6	22.6	27.6
20 x 16	47.0	47.2	47.0	15.3	19.3	32.1	17.4	17.6	28.9	20.6	22.6	27.6
18	43.0	43.1	43.0	17.2	17.2	29.3	19.6	20.1	33.1	23.1	23.3	31.5
20	47.0	47.2	47.0	19.3	19.3	32.0	22.2	21.3	36.2	27.0	27.3	35.4
22	51.0	51.4	51.0	21.3	21.3	34.3	22.1	22.2	36.8	26.7	29.7	31.5
24 x 20	55.0	55.4	55.0	19.3	23.3	37.0	22.2	21.3	36.2	27.0	27.3	35.4
24	55.0	55.4	55.0	23.3	23.3	37.0	24.6	23.5	41.1	30.8	37.4	27.6
26	57.0	57.5	57.0	25.0	25.0	40.0	25.1	25.1	43.2	29.7	28.6	31.5
30	65.0	65.5	65.0	29.0	29.0	44.5	28.3	31.5	49.4	32.9	28.6	31.5
36	82.0	82.6	82.0	34.5	34.5	51.8	32.9	34.1	58.7	37.4	28.6	35.4
Dimension (mm)												
2	292	295	292	51.0	51.0	165	155.0	106.3	165	580.0	—	—
3 x 2	356	359	356	51.0	76.2	210	155.0	106.3	165	580.0	—	—
3	356	359	356	76.2	76.2	210	170.0	136.3	229	700.0	—	—
4 x 3	432	435	432	76.2	101.6	273	170.0	136.3	229	700.0	—	—
4	432	435	432	103.4	103.3	273.1	197.0	162.3	264	850.0	—	—
6 x 4	559	562	559	103.4	152.4	356	197.0	162.3	264	850.0	—	—
6	559	562	559	152.4	152.4	356	230.0	234.5	319	285.0	360	500
8 x 6	660	664	660	152.4	203.2	419.1	230.0	234.5	319	285.0	360	500
8	660	664	660	203.0	203.2	419.1	290.5	316.0	432	342.5	380	600
10 x 8	787	791	787	203.0	254.0	508	290.5	316.0	432	342.5	380	600
10	787	791	787	254.0	254.0	508	329.0	399.0	518	393.0	418	600
12 x 10	838	841	838	254.0	304.8	559	329.0	399.0	518	393.0	418	600
12	838	841	838	304.8	304.8	558.8	404.7	451.0	622	474.7	545	700
14 x 12	889	892	889	304.8	337.0	603	404.7	451.0	622	474.7	545	700
16 x 12	991	994	991	304.8	387.4	686	404.7	451.0	622	474.7	545	700
14	889	892	889	337.0	337.0	603	400.0	388.5	638	481.0	588	800
16	991	994	991	387.4	387.4	686	443.0	445.8	735	524.0	575	700
20 x 16	1194	1200	1194	387.4	489.0	815	443.0	445.8	735	524.0	575	700
18	1092	1095	1092	438.0	438.0	743	498.0	510.5	840	587.0	592	800
20	1194	1200	1194	489.0	489.0	812.8	565.0	542.0	920	685.0	693	900
22	1295	1305	1295	539.8	539.8	870	561.8	563.0	935	677.2	753	800
24 x 20	1397	1407	1397	489.0	591.0	940	565.0	542.0	920	685.0	693	900
24	1397	1407	1397	591.0	591.0	940	624.5	596.0	1045	781.5	713	700
26	1448	1461	1448	635.0	635.0	1016	638.1	638.6	1097	753.7	726	800
30	1651	1664	1651	736.6	736.6	1130.3	719.2	799.7	1254.8	834.7	753	800
36	2083	2099	2083	876.3	876.3	1314.5	834.6	865.0	1490	950.2	763	900

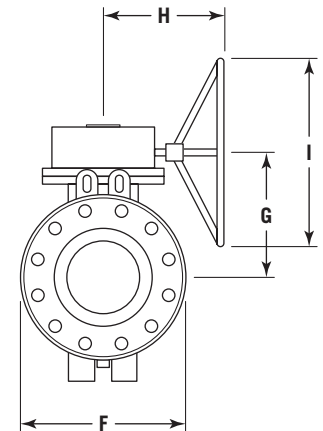
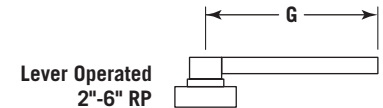
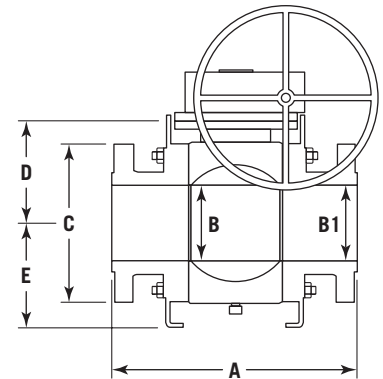

KF Series P3/M3 Dimensional Data

Dimensional Data (in., mm), 2"FP-26"FP, Class 900

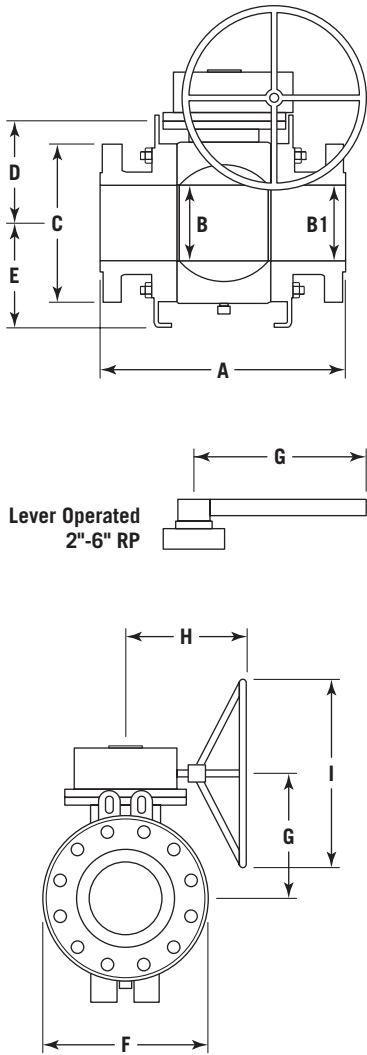

Size (in.)	Dimension (in.)											
	A/RF	A/RTJ	A/WE	B	B1	C	D	E	F	G	H	I
2	14.5	14.6	14.5	2.0	2.0	8.5	5.8	4.6	7.3	22.8	—	—
3 x 2	15.0	15.1	15.0	2.0	3.0	9.5	5.8	4.6	7.3	22.8	—	—
3	15.0	15.1	15.0	3.0	3.0	9.5	7.0	5.7	9.3	27.6	—	—
4 x 3	18.0	18.1	18.0	3.0	4.0	11.5	7.0	5.7	9.3	27.6	—	—
4	18.0	18.1	18.0	4.1	4.1	11.5	8.5	6.9	11.3	33.7	—	—
6 x 4	24.0	24.1	24.0	4.1	6.0	15.0	8.5	6.9	11.3	33.7	—	—
6	24.0	24.1	24.0	6.0	6.0	15.0	10.0	10.0	14.2	12.1	14.8	27.6
8 x 6	29.0	29.1	29.0	6.0	8.0	18.5	10.0	10.0	14.2	12.1	14.8	27.6
8	29.0	29.1	29.0	8.0	8.0	18.5	11.7	12.6	17.3	14.2	21.5	27.7
10 x 8	33.0	33.1	33.0	8.0	10.0	21.5	11.7	12.6	17.3	14.2	21.5	27.7
10	33.0	33.1	33.0	10.0	10.0	21.5	13.5	16.0	20.9	16.2	20.4	23.6
12 x 10	38.0	38.1	38.0	10.0	12.0	24.0	13.5	16.0	20.9	16.2	20.4	23.6
12	38.0	38.1	38.0	12.0	12.0	24.0	16.4	18.2	25.4	19.6	23.1	31.5
14 x 12	40.5	40.9	40.5	12.0	12.8	25.3	16.4	18.2	25.4	19.6	23.1	31.5
16 x 12	44.5	44.9	44.5	12.0	14.8	27.8	16.4	18.2	25.4	19.6	23.1	31.5
14	40.5	40.9	40.5	12.8	12.8	25.3	15.6	16.5	24.8	18.7	23.1	31.5
16	44.5	44.9	44.5	14.8	14.8	27.8	18.3	19.4	29.3	21.8	23.3	31.5
18	48.0	48.5	48.0	16.8	16.8	31.0	19.5	20.4	32.0	25.7	28.1	35.4
20	52.0	52.5	52.0	18.6	18.6	33.8	21.5	22.7	36.0	27.7	28.1	35.4
24	61.0	61.8	61.0	22.5	22.5	41.0	24.9	29.7	42.3	31.1	37.4	27.6
26	65.0	66.0	65.0	24.4	24.4	42.8	27.0	27.1	47.0	31.3	28.6	35.4
	Dimension (mm)											
2	368	371	368	50.8	50.8	215.9	148.5	116.8	185	580	—	—
3 x 2	381	384	381	50.8	76.2	241.3	148.5	116.8	185	580	—	—
3	381	384	381	76.2	76.2	241.0	179.0	144.3	237	700	—	—
4 x 3	457	460	457	76.2	101.6	292.1	179.0	144.3	237	700	—	—
4	457	460	457	103.3	103.3	292.0	211.0	176.3	288	850	—	—
6 x 4	610	613	610	103.3	152.4	381.0	216.2	176.3	288	856.2	—	—
6	610	613	610	152.4	152.4	381.0	255.0	255.0	360	307	377	600
8 x 6	737	740	737	152.4	203.2	470.0	255.0	255.0	360	307	377	600
8	737	740	737	203.2	203.2	469.9	296.0	320.0	440	360	545	700
10 x 8	838	841	838	203.2	254.0	546.0	296.0	320.0	440	360	545	700
10	838	841	838	254.0	254.0	546.0	342.0	406.0	532	412	518	600
12 x 10	965	968	965	254.0	304.8	610.0	342.0	406.0	532	412	518	600
12	965	968	965	304.8	304.8	609.6	416.0	462.5	645	497	558	800
14 x 12	1029	1038	1029	304.8	324.0	642.0	416.0	462.5	645	497	558	800
16 x 12	1130	1140	1130	304.8	374.7	705.0	416.0	462.5	645	497	558	800
14	1029	1038	1029	324.0	324.0	641.4	395.0	420.0	630	476	588	800
16	1130	1140	1130	374.7	374.65	705.5	465.5	491.9	745	554.5	592	800
18	1219	1232	1219	425.5	425.5	787.4	495.0	529.7	812	652.0	713.7	700
20	1321	1334	1321	473.1	473.1	857.3	547.0	589.6	915	704.0	713.7	700
24	1549	1568	1549	571.5	571.5	1041.4	632.5	641.0	1095	752.5	763	900
26	1651	1676	1651	619.1	619.8	1086.0	685.2	688.3	1195	800.5	763	900

KF Series P3/M3 Dimensional Data

Dimensional Data (in., mm), 2"FP- 16"FP, Class 1500

Size (in.)	Dimension (in.)											
	A/RF	A/RTJ	A/WE	B	B1	C	D	E	F	G	H	I
2	14.5	14.6	14.5	2.0	2.0	8.5	6.8	5.3	8.4	22.0	—	—
3x2	18.5	18.6	18.5	2.0	3.0	10.5	6.8	5.3	8.4	22.0	—	—
3	18.5	18.6	18.5	3.0	3.0	10.5	8.6	7.1	11.8	27.6	—	—
4x3	21.2	21.6	21.5	3.0	4.1	12.2	8.6	7.1	11.8	27.6	—	—
4	21.2	21.6	21.5	4.1	4.1	12.2	9.2	7.8	13.0	39.4	—	—
6x4	27.4	28.0	27.8	4.1	5.7	15.5	9.2	7.8	13.0	39.4	—	—
6	27.4	28.0	27.8	5.7	5.7	15.5	11.3	11.2	16.5	13.9	20.4	23.6
8x6	32.8	33.1	32.8	5.7	7.6	19.0	11.3	11.2	16.5	13.9	20.4	23.6
8	32.8	33.1	32.8	7.6	7.6	19.0	13.7	14.5	21.2	16.4	22.6	27.6
10x8	39.0	39.4	39.0	7.6	9.5	23.0	13.7	14.5	21.2	16.4	22.6	27.6
10	39.0	39.4	39.0	9.5	9.5	23.0	15.6	17.9	24.8	18.8	23.1	31.5
12x10	44.5	45.1	44.5	9.5	11.4	26.5	15.6	17.9	24.8	18.8	23.1	31.5
12	44.5	45.1	44.5	11.4	11.4	26.5	19.1	20.9	30.7	22.3	23.1	31.5
16	54.5	55.4	54.5	14.2	14.2	32.5	20.6	21.2	34.6	24.2	27.3	35.4
Dimension (mm)												
2	368	371	368	50.8	50.8	215.9	172	134.3	214	558.8	—	—
3x2	470	473	470	50.8	76.2	266.7	172	134.3	214	558.8	—	—
3	470	473	470	76.2	76.2	266.7	219	180.3	300	850	—	—
4x3	546	549	546	76.2	103.3	311	219	180.3	300	700	—	—
4	546	549	546	103.3	103.3	311	234.5	197.3	330	1000	—	—
6x4	705	711	705	103.3	146.0	394	234.5	197.3	330	1000	—	—
6	705	711	705	146	146.0	394	288	285	420	352	518	600
8x6	832	841	832	146	194.0	483	288	285	420	352	518	600
8	832	841	832	194	193.7	482.6	347	369	538	417	575	700
10x8	991	1000	991	194	241.0	585	347	369	538	417	575	700
10	991	1000	991	241	241.3	585	397	455	630	478	558	800
12x10	1130	1146	1130	241	289.0	673	397	455	630	478	588	800
12	1130	1146	1130	289	289.0	673	486	530	780	567	558	800
16	1384	1407	1384	368.3	368.3	825.5	523.9	539	877.9	614.4	693.4	900

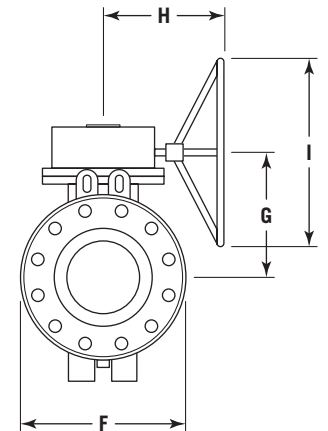
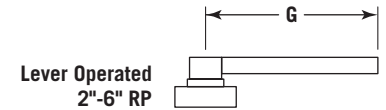
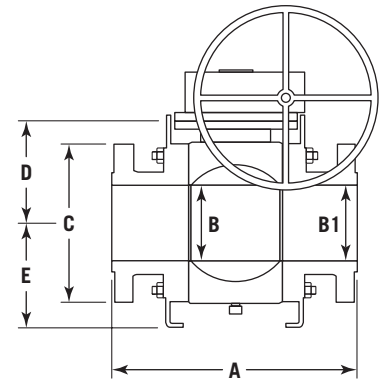

Dimensional Data (in., mm), 2"FP- 8"RP, Class 2500

Size (in.)	Dimension (in.)											
	A/RF	A/RTJ	A/WE	B	B1	C	D	E	F	G	H	I
2	17.8	17.9	17.8	1.8	1.8	9.3	7.2	5.1	9.4	27.6	—	—
3	22.8	23.0	22.8	2.5	2.5	12.0	8.8	6.6	12.1	33.5	—	—
4	26.5	26.9	26.5	3.5	3.5	14.0	9.8	7.1	13.8	12.3	16.5	23.6
6x4	36.0	36.5	36.0	3.5	5.3	19.0	9.8	7.1	13.8	12.3	16.5	23.6
6	36.0	36.5	36.0	5.3	5.3	19.0	13.4	10.4	15.0	16.2	22.6	27.8
8x6	40.3	40.9	40.3	5.3	7.1	21.8	13.4	10.4	15.0	16.2	22.6	27.8
Dimension (mm)												
2	451	454	451	44.5	44.5	235.0	183	130	238	700	—	—
3	578	584	578	63.5	63.5	304.8	223	168.5	308	850	—	—
4	673	683	673	88.9	88.9	355.6	249	181	350	313	418.1	600
6x4	914	927	914	88.9	133.4	482.6	249	181	350	312.4	418.1	600
6	914	927	914	133.4	133.4	482.6	341	265	500	411	575.1	700
8x6	1022	1038	1022	134.6	180.3	552.5	341	265	500	411	575.1	700

KF Series P3/M3 Weights

Size (in.)	ANSI Class	Weight (lbs.)				Weight (kg)			
		Valve Only	With Handle	GOP Wt.	With GOP	Valve Only	With Handle	GOP Wt.	With GOP
2FP	600	81	86	38	119	37	39	18	55
	900	114	118	54	168	52	54	25	77
	1500	169	173	54	223	77	79	25	101
	2500	478	—	65	543	217	220	30	246
3RP	600	96	101	38	134	44	46	18	62
	900	147	152	54	201	67	69	25	92
	1500	210	214	54	264	95	97	25	120
	2500	Consult Factory							
3FP	600	160	168	54	214	73	76	25	98
	900	216	223	54	270	98	101	25	123
	1500	386	390	45	431	175	179	21	196
	2500	539	—	65	604	245	248	30	274
4RP	600	216	223	54	270	98	101	25	123
	900	288	296	54	342	131	134	25	156
	1500	485	494	45	530	220	224	21	241
	2500	Consult Factory							
4FP	600	286	295	45	331	130	134	21	151
	900	385	395	45	430	175	179	21	196
	1500	617	—	81	698	280	—	37	317
	2500	807	—	90	897	366	—	41	407
6RP	600	368	377	45	413	167	171	21	188
	900	529	538	45	574	240	244	21	261
	1500	816	—	81	897	370	—	37	407
	2500	847	—	90	937	384	—	41	425
6FP	600	498	—	84	582	226	—	38	264
	900	762	—	92	854	346	—	42	388
	1500	1157	—	115	1272	525	—	53	577
	2500	1111	—	168	1279	504	—	76	580
8RP	600	604	—	84	688	274	—	38	312
	900	912	—	92	1004	414	—	42	456
	1500	1356	—	115	1471	615	—	53	668
	2500	1554	—	168	1722	705	—	76	781
8FP	600	992	—	90	1082	450	—	41	491
	900	1344	—	112	1456	610	—	51	661
10RP	1500	2149	—	196	2345	975	—	89	1064
	600	1256	—	90	1346	570	—	41	611
10FP	900	1499	—	112	1611	680	—	51	731
	1500	2628	—	196	2824	1192	—	89	1281
12RP	600	1653	—	115	1768	750	—	53	803
	900	2010	—	198	2208	912	—	90	1002
12FP	1500	3440	—	300	3740	1560	—	136	136
	600	1834	—	115	1949	832	—	53	885
12RP	900	2226	—	198	2424	1010	—	90	1100
	1500	4156	—	300	4456	1885	—	136	2021

Size (in.)	ANSI Class	Weight (lbs.)			Weight (kg)		
		Valve Only	GOP Wt.	With GOP	Valve Only	GOP Wt.	With GOP
12FP	600	2535	288	2823	1150	131	1281
	900	2865	299	3164	1300	136	1436
	1500	4012	300	4312	1820	136	1956
14RP	600	2491	288	2779	1130	131	1261
	150	1781	198	1979	808	90	898
14FP	300	2380	198	2578	1080	90	1170
	600	3020	288	3308	1370	131	1501
	900	3339	198	3537	1515	90	1605
16RP	150	1610	198	1808	730	90	820
	300	2332	198	2530	1058	90	1148
	600	3042	288	3330	1380	131	1511
	900	3947	198	4145	1790	90	1880
16FP	150	2799	198	2997	1270	90	1360
	300	2870	194	3064	1302	88	1390
	600	3791	293	4084	1720	133	1853
	900	4596	476	5072	2085	216	2301
	1500	9393	842	10,235	4261	382	4643
18FP	150	2921	293	3214	1325	133	1458
	300	4634	293	4927	2102	133	2235
	600	5742	476	6218	2605	216	2821
20RP	900	6614	842	7456	3001	382	3383
	150	2667	198	2865	1210	90	1300
	300	4909	293	5202	2227	133	2360
	600	4785	646	5431	2170	293	2464
20FP	900	6549	842	7391	2971	382	3353
	150	4805	289	5094	2180	131	2311
	300	5608	476	6084	2544	216	2760
	600	6130	842	6972	2781	382	3163
22FP	900	9614	842	10,456	4361	382	4743
	600	7762	904	8666	3521	410	3931
24RP	150	5343	289	5632	2424	131	2555
	300	6063	289	6352	2751	131	2882
	600	7475	842	8317	3391	382	3773
	900	12,303	842	13,145	5581	382	5963
24FP	150	7680	476	8156	3484	216	3700
	300	7960	842	8802	3611	382	3993
	600	12,125	870	12,995	5500	395	5895
	900	15,500	870	16,370	7031	395	7426
26FP	600	11,951	904	12,855	5421	410	5831
	900	17,320	915	18,235	7856	415	8271
30FP	600	17,960	915	18,875	8147	415	8562
36FP	600	28,919	915	29,834	13,117	415	13,532

Note: All weights listed are estimated. Consult factory for sizes not shown.

Topworks & Stem Data

Stem Detail

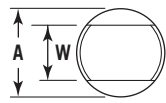

Flatted Stem 2" - 6"

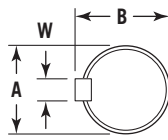

Sq. Key 8" - 24"

Topworks Detail

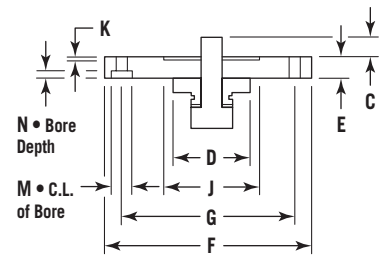
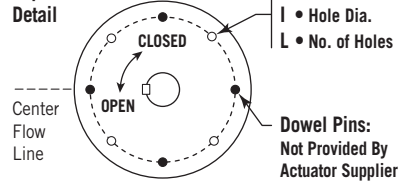

Bore Sz. (in.)	ANSI Class	Dimension (in.)															
		A	B	C	D	E	F	G	H	I	J	K	L	M	N	W	
2	600	0.871	—	1.319	3.760	0.709	5.906	4.921	1/2-13	0.531	—	—	4	0.787	0.512	*0.558	
	900	0.871	—	1.345	3.858	0.709	5.906	4.921	1/2-13	0.531	—	—	4	0.787	0.512	*0.558	
	1500	1.103	—	1.988	4.094	1.063	5.906	4.921	1/2-13	0.531	—	—	4	0.787	0.551	*0.746	
	2500	1.378	—	2.089	5.118	0.787	8.287	6.496	3/4-10	0.827	—	—	4	—	—	*0.994	
3	600	1.378	—	2.010	4.429	0.787	6.240	5.433	1/2-13	0.531	—	—	4	—	—	*0.994	
	900	1.378	—	2.000	4.941	0.945	6.713	5.433	1/2-13	0.531	—	—	4	0.807	0.500	*0.994	
	1500	1.493	—	1.973	4.921	1.181	6.693	5.512	5/8-11	0.657	—	—	4	1.024	0.650	*0.993	
	2500	1.493	—	1.890	4.921	0.591	8.268	6.496	3/4-10	0.827	5.124	0.157	4	—	—	*0.993	
4	600	1.497	—	1.687	5.020	1.220	6.890	5.512	5/8-11	0.657	3.939	0.118	4	0.984	0.630	*0.996	
	900	1.497	—	1.687	5.020	1.220	6.890	5.512	5/8-11	0.657	3.939	0.118	4	0.984	0.630	*0.996	
	1500	1.774	—	2.402	5.925	1.220	8.268	6.496	3/4-10	0.787	5.120	0.118	4	1.181	0.787	*1.247	
	2500	1.774	—	2.303	6.713	1.299	11.811	10.000	5/8-11	0.650	7.880	0.118	8	—	—	*1.247	
6	600	1.931	—	2.179	4.921	1.299	6.909	5.512	5/8-11	0.657	3.939	0.118	4	1.000	0.669	*1.247	
	900	1.992	—	1.991	4.921	1.378	8.287	6.496	3/4-10	0.787	5.120	0.118	4	1.181	0.787	*1.247	
	1500	2.493	—	2.795	6.299	1.181	11.811	10.000	5/8-11	0.669	7.880	0.118	8	—	—	*1.747	
	2500	2.493	—	2.874	7.087	1.378	11.811	10.000	5/8-11	0.669	7.880	0.118	8	—	—	*1.747	
8	600	2.870	3.191	3.588	6.297	1.732	8.287	6.496	3/4-10	0.787	5.120	0.157	4	1.165	0.787	0.750	
	900	2.870	3.191	3.780	6.496	1.575	11.811	10.000	5/8-11	0.669	7.877	0.157	8	—	—	0.750	
	1500	2.870	3.191	3.299	6.496	1.575	11.811	10.000	5/8-11	0.669	7.877	0.118	8	—	—	0.750	
	600	3.240	3.613	3.581	6.900	0.986	11.319	10.000	5/8-11	0.657	7.877	0.118	8	—	—	0.875	
10	900	3.240	3.617	3.972	7.096	1.260	11.811	10.000	5/8-11	0.657	7.877	0.118	8	—	—	0.875	
	1500	3.240	3.617	3.775	7.490	1.457	11.811	10.000	5/8-11	0.669	7.877	0.118	8	—	—	0.875	
	600	3.994	4.426	4.244	8.500	1.319	12.000	10.000	5/8-11	0.657	7.877	0.118	8	—	—	1.000	
	900	3.994	4.426	4.210	9.051	1.813	13.780	11.732	3/4-10	0.787	9.057	0.199	8	—	—	1.000	
12	1500	3.990	4.426	4.210	9.445	1.813	13.780	11.732	3/4-10	0.787	9.057	0.199	8	—	—	1.000	
	150	3.240	3.613	3.603	8.071	1.299	11.811	10.000	5/8-11	0.657	7.875	0.118	8	—	—	0.875	
	300	3.240	3.613	3.603	8.071	1.299	11.811	10.000	5/8-11	0.657	7.875	0.118	8	—	—	0.875	
	600	3.240	3.613	3.603	8.071	1.299	13.780	11.732	3/4-10	0.787	9.057	0.118	8	—	—	0.875	
14	900	3.240	3.613	3.287	7.874	1.457	13.780	11.732	3/4-10	0.827	9.057	0.118	8	—	—	0.875	
	150	3.240	3.613	3.838	8.228	1.299	11.811	10.000	5/8-11	0.657	7.875	0.118	8	—	—	0.875	
	300	3.240	3.613	3.838	8.228	1.299	11.811	10.000	5/8-11	0.657	7.875	0.118	8	—	—	0.875	
	600	4.333	4.749	4.114	8.898	1.299	13.228	11.732	3/4-10	0.787	9.057	0.118	8	—	—	1.000	
16	900	4.333	4.749	4.568	8.543	1.000	13.780	11.732	3/4-10	0.787	9.057	0.118	8	—	—	1.000	
	1500	3.541	3.743	5.785	9.071	1.299	16.339	14.016	M30-3.5	1.299	—	—	8	—	—	0.984	
	150	4.333	4.749	3.996	9.055	1.299	13.228	11.732	3/4-10	0.787	9.057	0.118	8	—	—	1.000	
	300	4.333	4.749	3.996	9.055	1.299	13.228	11.732	3/4-10	0.787	9.057	0.118	8	—	—	1.000	
18	600	4.333	4.749	3.996	9.055	1.299	13.780	11.732	3/4-10	0.787	9.057	0.118	8	—	—	1.000	
	900	4.742	5.284	3.267	11.807	1.000	18.701	15.984	1 1/2-8	1.575	11.819	0.315	8	—	—	1.250	
	150	4.333	4.749	4.528	9.248	1.000	13.386	11.732	3/4-10	0.787	9.057	0.118	8	—	—	1.000	
	300	4.323	4.749	4.449	9.248	1.417	13.780	11.732	3/4-10	0.787	9.057	0.118	8	—	—	1.000	
20	600	4.333	4.749	4.382	9.839	1.000	13.780	11.732	3/4-10	0.787	9.057	0.118	8	—	—	1.000	
	900	4.742	5.284	5.118	11.807	1.000	18.701	15.984	1 1/2-8	1.575	11.819	0.315	8	—	—	1.250	
	22	600	4.723	5.003	7.340	10.055	1.496	13.386	11.732	M20-2.5	0.866	—	—	8	—	—	1.260
	150	4.333	4.749	4.429	9.248	1.417	13.780	11.732	3/4-10	0.787	9.057	0.118	8	—	—	1.000	
24	300	4.333	4.749	4.429	9.248	1.417	13.780	11.732	3/4-10	0.787	9.057	0.118	8	—	—	1.000	
	600	4.725	5.257	4.331	11.020	2.362	18.701	15.984	1 1/2-8	1.575	11.819	0.394	8	—	—	1.250	
	900	5.741	6.391	6.259	12.386	1.181	18.701	15.984	1 1/2-8	1.575	11.817	0.118	8	—	—	1.500	
	26	600	4.723	5.003	7.264	10.055	1.496	16.339	14.016	M30-3.5	1.299	—	—	8	—	—	1.260
30	900	5.904	6.223	8.915	13.205	1.496	18.701	15.984	M36-4	1.535	—	—	8	—	—	1.417	
	600	5.904	6.223	8.935	12.614	1.496	18.701	15.984	M36-4	1.535	—	—	8	—	—	1.417	
36	600	5.904	6.223	6.592	12.614	1.496	18.701	15.984	M36-4	1.535	—	—	8	—	—	1.417	

*Stem with Double 'D' Flat Style

Topworks & Stem Data

Stem Detail

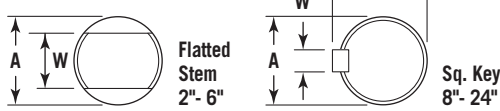

Topworks Detail

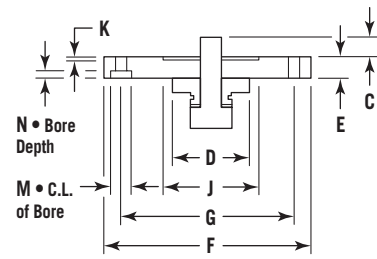
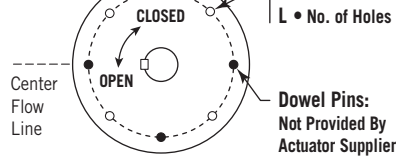

Bore Sz. (in.)	ANSI Class	Dimension (mm)														
		A	B	C	D	E	F	G	H	I	J	K	L	M	N	W
2	600	22.1	—	33.5	95.5	18.0	150.0	125	1/2-13	13.5	—	—	4	20.0	13.0	*14.17
	900	22.1	—	34.2	98.0	18.0	150.0	125	1/2-13	13.5	—	—	4	20.0	13.0	*14.17
	1500	28.0	—	50.5	104.0	27.0	150.0	125	1/2-13	13.5	—	—	4	20.0	14.0	*18.95
	2500	35.0	—	53.1	130.0	20.0	210.5	165	3/4-10	21.0	—	—	4	—	—	*25.25
3	600	35.0	—	51.1	112.5	20.0	175.0	138	1/2-13	13.5	—	—	4	—	—	*25.25
	900	35.0	—	50.8	125.5	24.0	175.0	138	1/2-13	13.5	—	—	4	20.5	12.7	*25.25
	1500	37.9	—	50.1	125.0	30.0	170.0	140	5/8-11	16.7	—	—	4	26.0	16.5	*25.22
	2500	37.9	—	48.0	125.0	15.0	210.0	165	3/4-10	21.0	130.1	4.0	4	—	—	*25.22
4	600	38.0	—	48.9	127.5	31.0	175.0	140	5/8-11	16.7	100.1	3.0	4	25.0	16.0	*25.30
	900	38.0	—	48.9	127.5	31.0	175.0	140	5/8-11	16.7	100.1	3.0	4	25.0	16.0	*25.30
	1500	45.1	—	61.0	150.5	31.0	210.0	165	3/4-10	20.0	130.0	3.0	4	30.0	20.0	*31.67
	2500	45.1	—	58.5	170.5	33.0	300.0	254	5/8-11	16.5	200.2	3.0	8	—	—	*31.67
6	600	49.0	—	55.3	125.0	33.0	175.5	140	5/8-11	16.7	100.1	3.0	4	25.4	17.0	*31.67
	900	50.6	—	50.6	125.0	35.0	210.5	165	3/4-10	20.0	130.0	3.0	4	30.0	20.0	*31.67
	1500	63.3	—	71.0	160.0	30.0	300.0	254	5/8-11	17.0	200.2	3.0	8	—	—	*44.37
	2500	63.3	—	73.0	180.0	35.0	300.0	254	5/8-11	17.0	200.2	3.0	8	—	—	*44.37
8	600	72.9	81.1	91.1	159.9	44.0	210.5	165	3/4-10	20.0	130.0	4.0	4	29.6	20.0	19.05
	900	72.9	81.1	96.0	165.0	40.0	300.0	254	5/8-11	17.0	200.1	4.0	8	—	—	19.05
	1500	72.9	81.1	83.8	165.0	40.0	300.0	254	5/8-11	17.0	200.1	3.0	8	—	—	19.05
	2500	82.3	91.8	91.0	175.3	25.0	287.5	254	5/8-11	16.7	200.1	3.0	8	—	—	22.23
10	600	82.3	91.9	100.9	180.2	32.0	300.0	254	5/8-11	16.7	200.1	3.0	8	—	—	22.23
	900	82.3	91.9	95.9	190.2	37.0	300.0	254	5/8-11	17.0	200.1	3.0	8	—	—	22.23
	1500	82.3	91.9	95.9	190.2	37.0	300.0	254	5/8-11	17.0	200.1	3.0	8	—	—	22.23
	2500	101.4	112.4	107.8	215.9	33.5	304.8	254	5/8-11	16.7	200.1	3.0	8	—	—	25.40
12	600	101.4	112.4	106.9	229.9	46.1	350.0	298	3/4-10	20.0	230.0	5.0	8	—	—	25.40
	900	101.4	112.4	106.9	239.9	46.1	350.0	298	3/4-10	20.0	230.0	5.0	8	—	—	25.40
	1500	101.3	112.4	106.9	239.9	46.1	350.0	298	3/4-10	20.0	230.0	5.0	8	—	—	25.40
	2500	150	82.3	91.8	205.0	33.0	300.0	254	5/8-11	16.7	200.0	3.0	8	—	—	22.23
14	300	82.3	91.8	91.5	205.0	33.0	300.0	254	5/8-11	16.7	200.0	3.0	8	—	—	22.23
	600	82.3	91.8	91.5	205.0	33.0	350.0	298	3/4-10	20.0	230.0	3.0	8	—	—	22.23
	900	82.3	91.8	83.5	200.0	37.0	350.0	298	3/4-10	21.0	230.0	3.0	8	—	—	22.23
	1500	82.3	91.8	97.5	209.0	33.0	300.0	254	5/8-11	16.7	200.0	3.0	8	—	—	22.23
16	300	82.3	91.8	97.5	209.0	33.0	300.0	254	5/8-11	16.7	200.0	3.0	8	—	—	22.23
	600	110.1	120.6	104.5	226.0	33.0	336.0	298	3/4-10	20.0	230.0	3.0	8	—	—	25.40
	900	110.1	120.6	116.0	217.0	25.4	350.0	298	3/4-10	20.0	230.0	3.0	8	—	—	25.40
	1500	89.9	95.1	146.9	230.4	33.0	415.0	356	M30-3.5	33.0	—	—	8	—	—	24.99
18	150	110.1	120.6	101.5	230.0	33.0	336.0	298	3/4-10	20.0	230.0	3.0	8	—	—	25.40
	300	110.1	120.6	101.5	230.0	33.0	336.0	298	3/4-10	20.0	230.0	3.0	8	—	—	25.40
	600	110.1	120.6	101.5	230.0	33.0	350.0	298	3/4-10	20.0	230.0	3.0	8	—	—	25.40
	900	120.4	134.2	83.0	299.9	25.4	475.0	406	1 1/2-8	40.0	300.2	8.0	8	—	—	31.75
20	150	110.1	120.6	115.0	234.9	25.4	340.0	298	3/4-10	20.0	230.0	3.0	8	—	—	25.40
	300	109.8	120.6	113.0	234.9	36.0	350.0	298	3/4-10	20.0	230.0	3.0	8	—	—	25.40
	600	110.1	120.6	111.3	249.9	25.4	350.0	298	3/4-10	20.0	230.0	3.0	8	—	—	25.40
	900	120.4	134.2	130.0	299.9	25.4	475.0	406	1 1/2-8	40.0	300.2	8.0	8	—	—	31.75
22	600	120.0	144.0	186.4	255.4	38.0	340.0	298	M20-2.5	22.0	—	—	8	—	—	32.00
	150	110.1	120.6	112.5	234.9	36.0	350.0	298	3/4-10	20.0	230.0	3.0	8	—	—	25.40
	300	110.1	120.6	112.5	234.9	36.0	350.0	298	3/4-10	20.0	230.0	3.0	8	—	—	25.40
	600	120.0	133.5	110.0	279.9	60.0	475.0	406	1 1/2-8	40.0	300.2	10.0	8	—	—	31.75
24	900	145.8	162.3	159.0	314.6	30.0	475.0	406	1 1/2-8	40.0	300.2	3.0	8	—	—	38.10
	600	120.0	127.1	184.5	255.4	38.0	415.0	356	M30-3.5	33.0	—	—	8	—	—	32.00
	900	150.0	158.1	226.4	335.4	38.0	475.0	406	M36-4	39.0	—	—	8	—	—	35.99
	30	600	150.0	174.0	227.0	320.4	38.0	475.0	406	M36-4	39.0	—	—	8	—	35.99
36	600	150.0	174.0	167.4	320.4	38.0	475.0	406	M36-4	39.0	—	—	8	—	—	35.99

*Stem with Double 'D' Flat Style

KF Series P3/M3 Engineering Data

Flow Coefficient (Cv)

Size (in.)	Flow Coefficient (Cv)				
	285 psi	740 psi	1480 psi	2220 psi	3705 psi
2	—	—	350	320	330
3 x 2	—	—	190	185	187
3	—	—	1000	910	830
4 x 3	—	—	560	505	510
4	—	—	1850	1760	1660
6 x 4	—	—	800	730	742
6	—	—	4400	4300	4167
8 x 6	—	—	2150	2010	2033
8	—	—	8450	8400	8013
10 x 8	—	—	4500	4160	4051
10	—	—	14,250	14,160	13,309
12 x 10	—	—	8000	7300	7117
12	—	—	22,790	21,230	17,073
14 x 12	—	—	13,990	—	—
16 x 12	—	—	—	—	—
14	32,600	30,900	28,600	26,600	—
16 x 14	14,780	14,750	14,720	14,690	—
16	44,700	42,600	39,250	36,600	33,215
20 x 16	14,870	14,860	14,850	14,830	—
18	57,825	56,225	57,410	48,665	—
20	74,775	71,800	65,463	62,239	—
22	—	—	81,305	—	—
24	113,284	109,414	98,963	93,993	—
26	—	—	114,650	102,940	—
30	—	—	158,900	—	—
36	—	—	226,300	—	—

Note: Consult factory for torque data and sizes not shown.

Method of Calculating Flow

The flow coefficient "Cv" of a valve is the flow rate of water (gallons/minute) through a fully opened valve, with a pressure drop of 1 psi across the valve. To find the flow of liquid through valve from the Cv, use the following formulas:

Liquid Flow

QL = Flow rate of liquid (gal./min.)
 ΔP = Differential pressure across the valve (psi)
 G = Specific gravity of liquid (for water, G=1)

$$Q_L = C_v \sqrt{\frac{\Delta P}{G}}$$

Gas Flow

Qg = Flow rate of gas (CFH at STP)
 P2 = Outlet pressure (psia)
 g = Specific gravity of gas (for air, g=1.000)

$$Q_g = 61 C_v \sqrt{\frac{P_2 \Delta P}{g}}$$

For non-critical flow

$$\left\{ \frac{\Delta P}{P_2} < 1.0 \right\}$$

Pressure Temperature

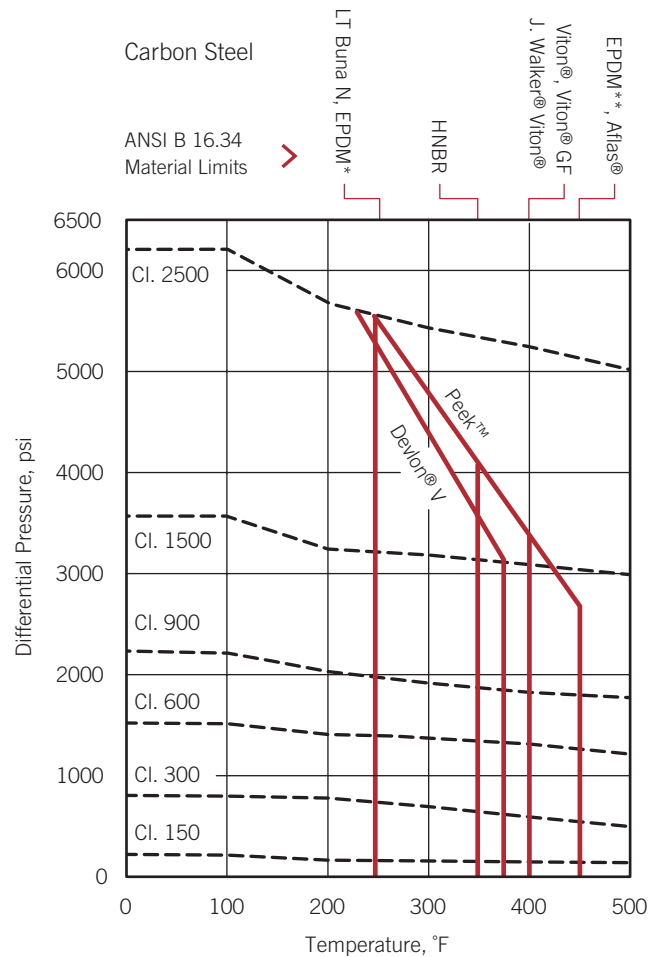

*For chemical service.

**For water and steam service only.

Pressure Rating (psig)

Material	ANSI Class				
	150	300	600	900	1500
CS, LTCS	285	740	1480	2220	3705
SS	275	720	1440	2160	3600

Low Temperature Limits

Body Material	°F	°C
CS	-20	-29
LTCS and SS	-50	-46

Seat Material	°F	°C
Devlon® V and PEEK™	-50	-46

Seal Material	°F	°C
Viton®	-20	-29
HNBR	-40	-40
LT HNBR	-50	-46

KF Series P3/M3 Optional Accessories & Installation

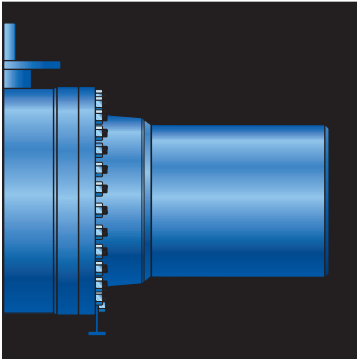

Pups

Buttweld valves may be supplied with transition pieces (PUPS) to avoid any risk of seat and seal damage during welding and post weld heat treatment operations. Length of pups and type of pipe and grade to be specified by customer.

Extensions

KF series P3/M3 ball valves are available for below ground or buried service with fully operational extensions to meet your specifications. Body bleed and sealant injection functions are maintained along with total valve control by manual or powered actuators. Extension dimensions for gear operator or actuator are given with reference from the valve center line to the center of hand wheel.

External Coating

KF series P3/M3 ball valves can be coated for added corrosion protection to meet specific application requirements. Coating is available upon request. Ask your KF Valves representative for more information on this special coating process.

Actuation

The bonnet design on KF series P3/M3 ball valves permits easy adaptation to mount manual, electric, hydraulic or pneumatic actuators.

Metal Seated Ball Valves

KF series P3/M3 metal seated ball valves have been designed to provide a reliable, efficient and safe method to handle services where high temperatures and/or the presence of solid particles in the fluid make it not recommended to use soft seated ball valves.

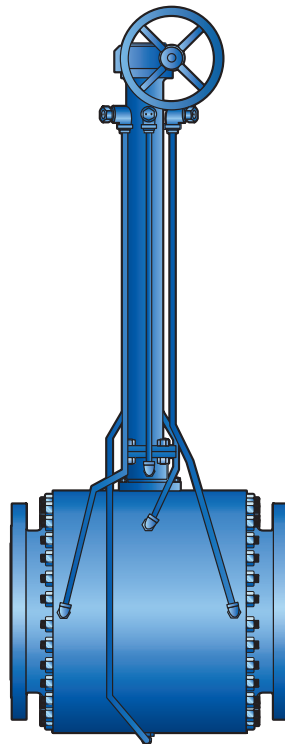

Installation

Flange Ends (RF & RTJ)

- Series P3/M3 ball valves may be mounted in either vertical or horizontal piping systems. The stem may be positioned vertically or horizontally.
- Mating flanges must be correctly aligned. Alignment includes bolt hole placement, parallelism and perpendicularity.
- Use proper size gasket or RTJ metal seal. Flange studs or bolting must be correct size and properly tightened.
- Properly constructed piping systems do not cause undue stress in valve assemblies. Valves are not intended to make up for insufficient pipe tolerances.

Weld Ends (WE)

- Keep ball in open position prior to installation/welding of KF series P3/M3 weld end ball valves.
- Place the valve in position by aligning weld ends to the pipe. Prior to welding it is imperative that all welding surfaces be clean from contamination such as dirt, dust and grease which may affect weld performance.
- **Caution:** During the welding process, valve body temperatures should be monitored around the circumference at a location in line with the sealant injection fittings. The temperatures at this plane should be checked with temperature stick or other reliable temperature indicator and not allowed to exceed 300°F. This precaution is necessary to assure that non-metallic seals do not suffer heat damage.
- Tack weld valve in position and check for proper alignment.
- Finish weld following proper weld procedure for material grade and condition, and the above caution.

Distributed by | Distribuido por :



ANYTHINGTM
≈ FLOWS ≈

INFO@ANYTHINGFLOWS.COM

WWW.ANYTHINGFLOWS.COM

Flow Control , our passion ®

Life Flows on TM



SCAN ME