

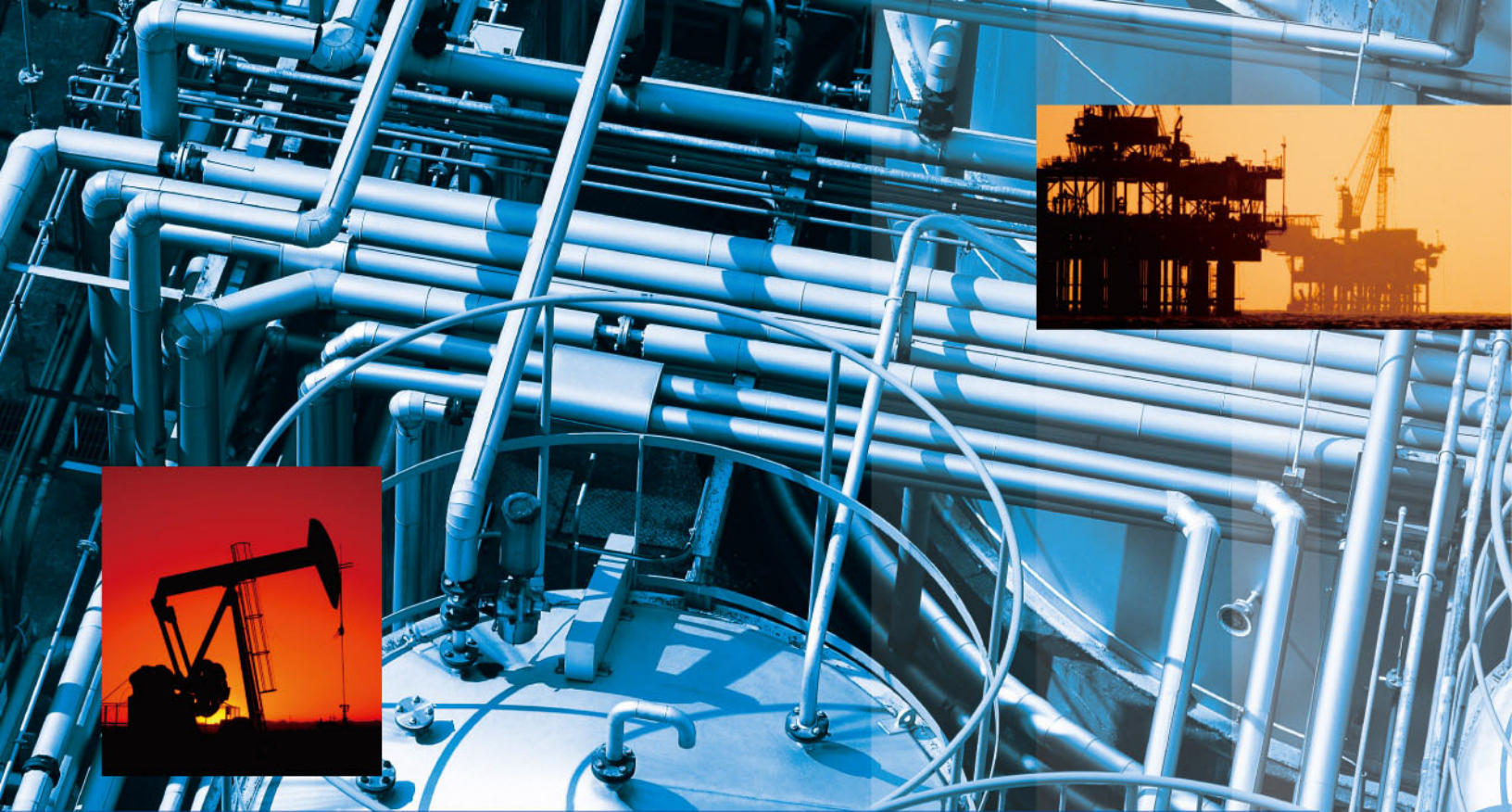

ENERGY SERVICES  
BALL VALVE CATALOG



FLANGED END  
FLOATING TYPE  
BALL VALVES  
AND  
TWO PIECE TRUNNION  
MOUNTED BALL VALVES



ISV brand of ball valves are manufactured under the most stringent production and quality procedures starting with the valve design, material selection, manufacturing & production through final assembly and performance testing.

Each product is manufactured in strict compliance with applicable industry standards.

ISV floating and trunnion supported valves are designed and manufactured to exceed the most demanding service applications of oilfield, natural gas pipeline, gas distribution and process industry requirements. Each valve meets ASME B16.34, API 608 and API 6D as applicable to its design.

Many features normally considered as an option is provided as a standard feature of the ISV ball valve product. A variety of body materials, seat and seal materials are available to meet the needs of customer specific applications.

## ISV Design and Production Standards

- All production is conducted under ISO 9001 certified Quality Management Systems.
- Product engineering is performed under our documented design control process - ISV Design Control File system.
- Products are stringently manufactured in accordance with applicable industry standards and to specific controlled ISV Product Design Specifications.
- Product quality is achieved through data monitoring of key production processes for continuous quality improvement.
- Designs are compliant with ASME B16.34, API 608 and API 6D.
- Pressure testing to API 6D and API 598
- Fire testing certified to API 607
- All pressure containing components meet the predefined material requirements of NACE MR-0175/ISO 15156 or NACE MR-0103.
- Material Test Reports per EN 10204-1991 3.1.B & EN 10204-2004 3.1 are available.

# OVERVIEW OF PRODUCT FEATURES

## ISV Series No. BF3BF

### O RING STYLE FLANGED END FLOATING BALL VALVE DESIGN

#### Product Certifications

API 6D

API 607

PED CE

2-piece bolted body design

Designed to ASME B16.34, API 608 & API 6D

Manufactured, tested and monogrammed in accordance with API 6D

Each valve is uniquely serialized for enhanced manufacturing traceability.

Fire tested to API 607 6<sup>th</sup> Edition

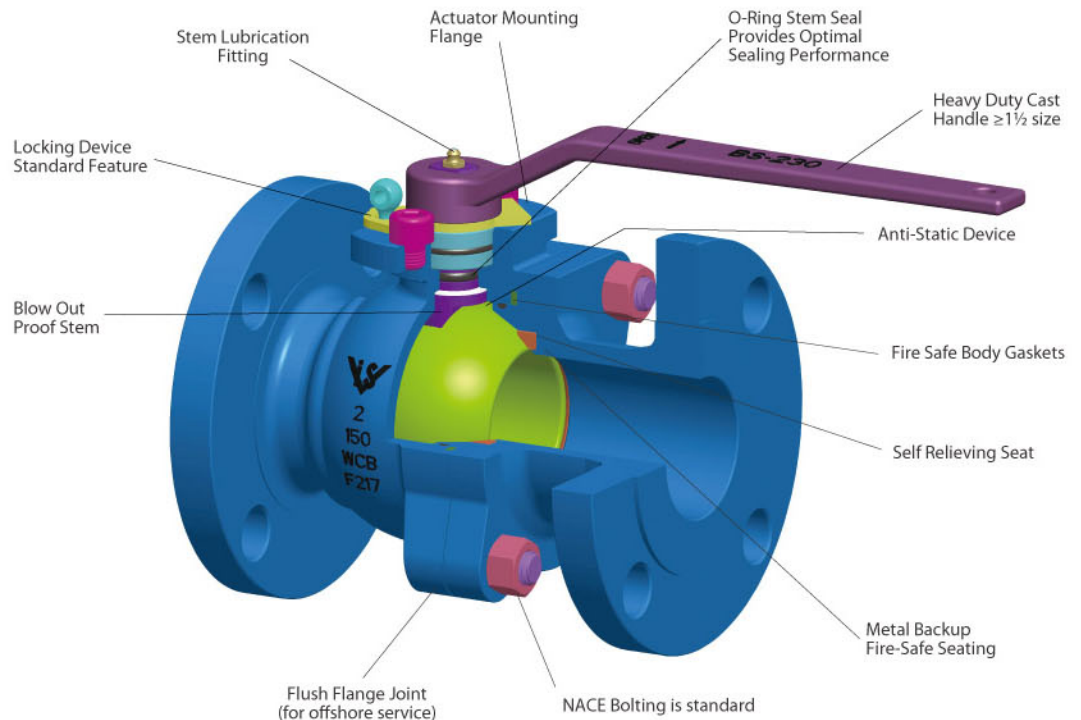

## ISV Series No. BT3BF

### TWO PIECE CONSTRUCTION TRUNNION MOUNTED BALL VALVE DESIGN

#### Product Certifications

API 6D

API 607

PED CE

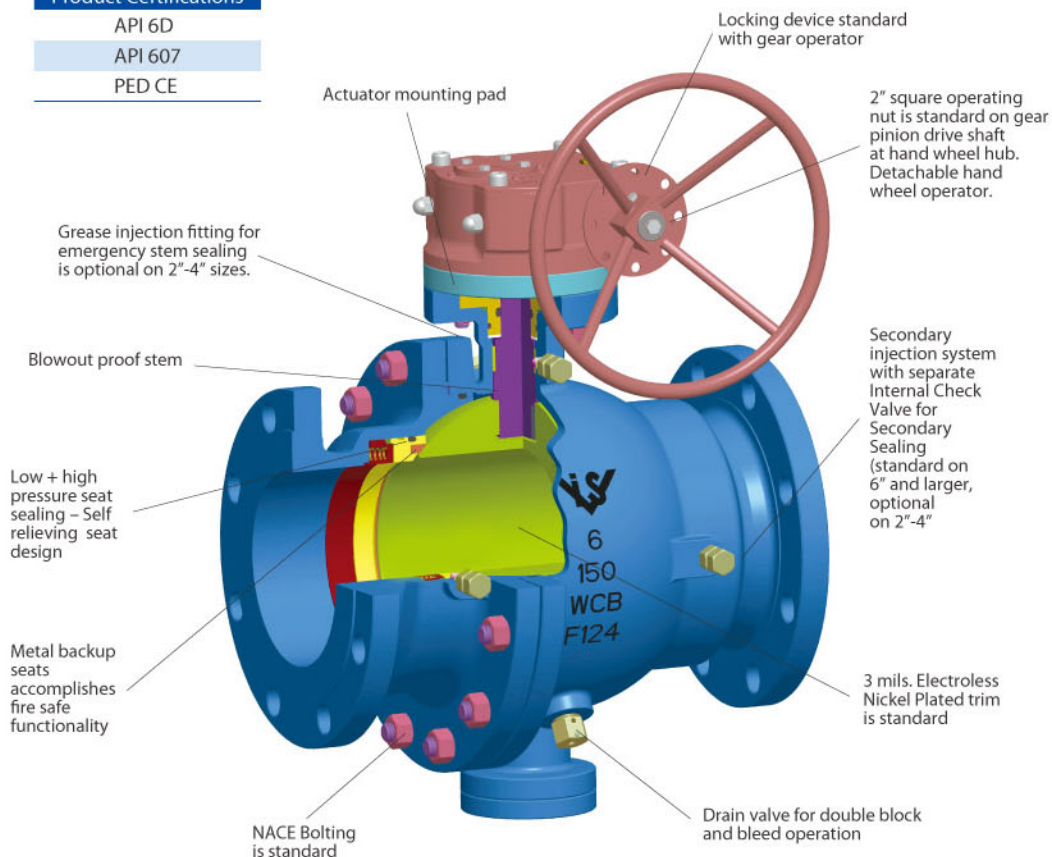

2-piece bolted body design.

Design meets API 6D, API 608 & ASME B16.34.

Manufactured, tested and monogrammed in accordance with API 6D.

Rugged polymeric seats material

Each valve is uniquely serialized for enhanced traceability.

Fire safe tested to API 607 5<sup>th</sup> Edition

## ISV Series No. BF3BF Floating Ball Valves

Design Standards	
Basic Design	API 608 + API 6D
	ASME B16.34
Face to Face Dimension	ASME B16.10
	API 6D
Flanged Ends	ASME B16.5
Pressure Test	API 598
	API 6D

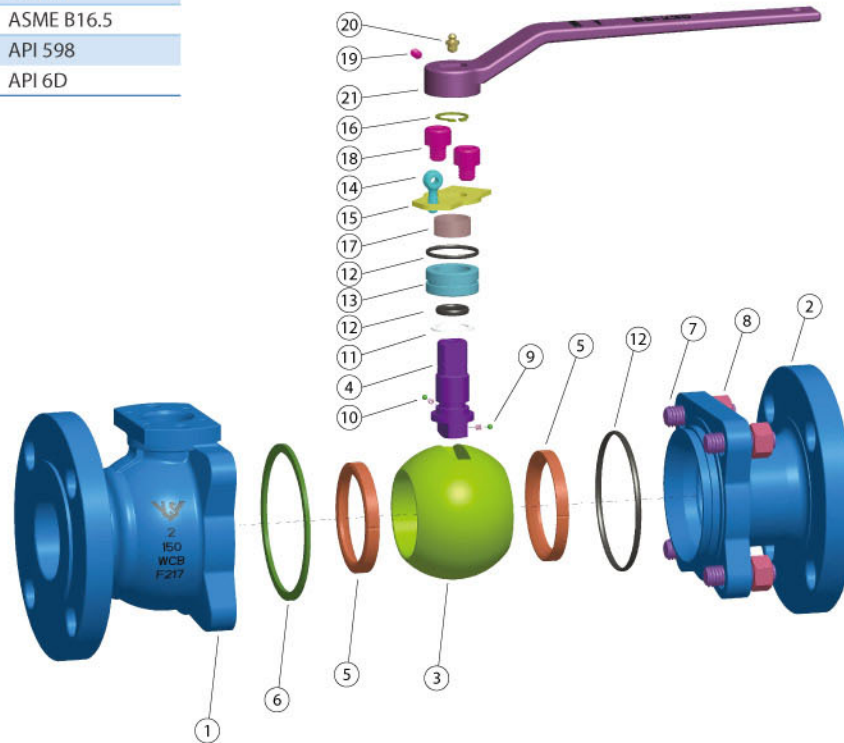

### Material List of Floating Ball Valve

No	Part Name	Material		
1	Body	A216 Grade WCB	A352 Grade LCC	CF8M
2	End Cap	A216 Grade WCB	A352 Grade LCC	CF8M
3	Ball	A182 Grade F316 / CF8M		
4	Stem	A276 Type 316		
5	Seat Ring	TFM 4215		
6	Body Gasket	Flexible Graphite		
7	Body-Cap Stud	A193 Grade B7M	A320 Grade L7M	A193 B8
8	Body-Cap Nut	A194 Grade 2HM	A194 Grade 4M	A194 8
9	Small Spring	SS304		
10	Small Ball	SS304		
11	Thrust Washer	PTFE		
12	O-Ring	HNBR		
13	Gland	A276 Type 316		
14	Eye Bolt	Carbon Steel		
15	Stop Plate	Carbon Steel		316SS
16	Retaining Ring	301 Stainless Steel		
17	Stem Bearing	PTFE		
18	Socket Cap Screw	Carbon Steel		S.S.
19	Set Screw	Carbon Steel		S.S.
20	Grease Nipple	316 Stainless Steel		
21	Wrench	Carbon Steel		

## ISV Series No. BF3BF Floating Ball Valves

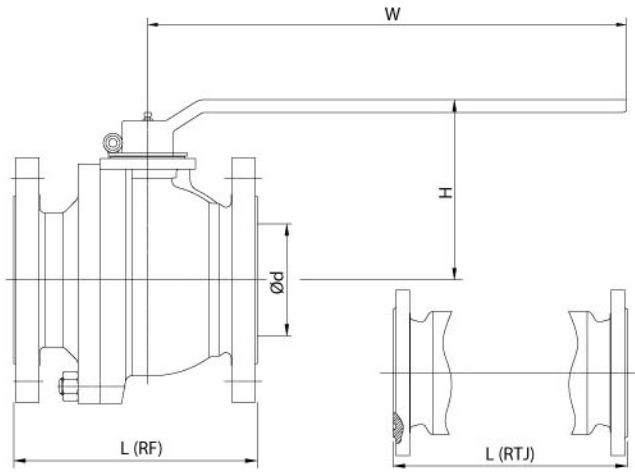

Pressure Test to API 6D (WCB)			
	Shell Test (Hydrostatic)	Seat Test (Hydrostatic)	Seat Test (Air)
Class 150	450 psi	313 psi	80 psi
Class 300	1125 psi	814 psi	80 psi
Class 600	2225 psi	1628 psi	80 psi

Maximum operating pressure at maximum temperature (degrees F.)

1/2", 3/4", 1"			1 1/2", 2", 2 1/2", 3"			4"			6", 8"	
Class 150	Class 300	Class 600	Class 150	Class 300	Class 600	Class 150	Class 300	Class 600	Class 150	Class 300
seat TFM4215	seat TFM4215	seat TFM4215	seat TFM4215	seat TFM4215	seat TFM4215	seat TFM4215	seat TFM4215	seat TFM4215	seat TFM4215	seat TFM4215
285 psi @ -20F	740 psi @ -20F	1480 psi @ -20F	285 psi @ -20F	740 psi @ -20F	1480 psi @ -20F	285 psi @ -20F	740 psi @ -20F	1050 psi @ -20F	285 psi @ -20F	740 psi @ -20F
179 psi @ 470F	625 psi @ 425F	1295 psi @ 325F	185 psi @ 450F	650 psi @ 325F	1465 psi @ 110F	190 psi @ 425F	690 psi @ 180F	950 psi @ 110F	220 psi @ 325F	450 psi @ 125F

### Dimensions and Weight

Class 150											
Valve Size	NPS	1/2"	3/4"	1"	1 1/2"	2"	2 1/2"	3"	4"	6"	8"
d	inch	0.50	0.75	1.00	1.50	2.00	2.50	3.00	4.00	6.00	8.00
L (RF)	inch	4.25	4.60	5.00	6.50	7.00	7.50	8.00	9.00	15.50	18.00
L (RTJ)	inch	-	-	5.50	7.00	7.50	8.00	8.50	9.50	16.00	18.50
H	inch	3.25	3.25	3.60	4.25	4.50	5.25	5.40	6.70	8.75	10.50
W	inch	6.30	6.30	7.10	9.00	9.00	14.20	14.20	17.75	27.60	29.50
Weight	lbs	5.00	7.00	10.00	15.00	33.00	44.00	55.00	88.00	214.00	352.00

Class 300											
Valve Size	NPS	1/2"	3/4"	1"	1 1/2"	2"	2 1/2"	3"	4"	6"	-
d	inch	0.50	0.75	1.00	1.50	2.00	2.50	3.00	4.00	6.00	-
L (RF)	inch	5.50	6.00	6.50	7.50	8.50	9.50	11.13	12.00	15.88	-
L (RTJ)	inch	6.00	6.50	7.00	8.00	9.13	10.12	11.75	12.64	16.50	-
H	inch	3.25	3.25	3.60	4.25	4.50	5.25	5.40	6.70	8.75	-
W	inch	6.30	6.30	7.10	9.00	9.00	10.25	14.20	17.75	27.60	-
Weight	lbs	6.00	8.00	12.00	23.00	44.00	55.00	69.00	115.00	260.00	-

Class 600											
Valve Size	NPS	1/2"	3/4"	1"	1 1/2"	2"	2 1/2"	2 1/2"	4"	-	-
d	inch	0.50	0.75	1.00	1.50	2.00	2.50	3.00	4.00	-	-
L (RF)	inch	6.50	7.50	8.50	9.50	11.50	13.00	14.00	17.00	-	-
L (RTJ)	inch	6.38	7.50	8.50	9.50	11.63	13.13	14.13	17.13	-	-
H	inch	3.25	3.25	4.13	4.67	4.75	6.50	6.90	7.60	-	-
W	inch	6.25	6.25	7.13	9.00	14.20	17.75	17.75	27.60	-	-
Weight	lbs	17.00	23.00	32.00	41.00	84.00	123.00	125.00	168.00	-	-

## ISV Series No. BT3BF Trunnion Mounted Ball Valves

Design Standards	
Basic Design	API 6D, API 608
	ASME B16.34
Face to Face Dimension	ASME B16.10
	API 6D
Flanged Ends	ASME B16.5
Pressure Test	API 6D

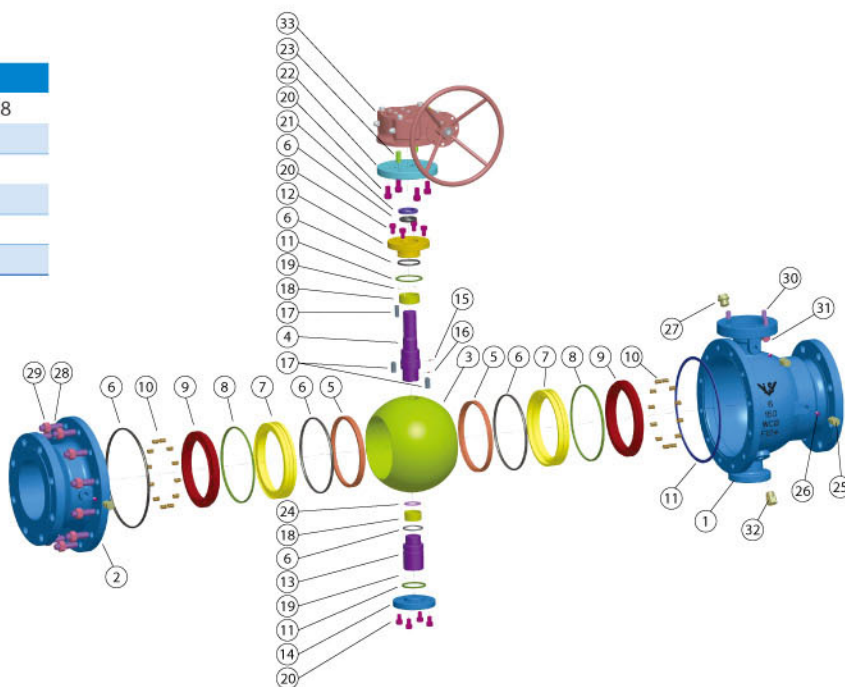

Material List of Trunnion Ball Valve

No	Part Name	Material		
1	Body	A216 WCB	A352 LCC	A351 CF8M
2	End Cap	A216 WCB	A352 LCC	A351 CF8M
3	Ball	A105N + ENP	Low temp. A350 LF2 + ENP	A182 F316
4	Stem	C.S. + ENP	Low temp. C.S. + ENP	17-4PH
5	Seat Insert	Devlon V 1) (Class 150 & 300: 15% glass filled PTFE)		
6	O-Ring	HNBR	Low Temp. HNBR	HNBR
7	Seat Ring	A105N+ENP	A350 LF2+ENP	A182 F316
8	Seat Gasket	Graphite		
9	Seat Pusher	A105N+ENP	A350 LF2+ENP	A182 F316
10	Seat Spring	Inconel X-750		
11	Gasket	Graphite (SPW Graphite body-cap gasket 2)		
12	Gland	A105N+ENP	A350 LF2+ENP	A182 F316
13	Trunnion	A105N + ENP, (AISI 1045 + ENP sizes 6" - 12" class 150 & class 300)		A182 F316
14	Trunnion Cover <sup>3)</sup>	A105N	A350 LF2	A182 F316
15	Anti-static ball	304SS		
16	Anti-static spring	304SS		
17	Stem key	C.S.		
18	Bearing	C.S + PTFE (DU)		S.S. + PTFE
19	Thrust Washer	C.S + PTFE (DU), (PTFE 2"-4" class 150 & class 300)		S.S. + PTFE
20	Socket Cap Screw	A193 B7M	A320 L7M	A193 B8
21	Fire Seal Packing	Graphite		
22	Top Plate	A105+ENP		A182 F316
23	Pin	C.S.		
24	Ball Thrust Washer	PTFE 4)		
25	Grease Injection Fitting	Zinc plated carbon steel		316SS
26	Internal Check Valve	Zinc plated carbon steel		316SS
27	Vent Plug	Zinc plated carbon steel		316SS
28	Body Stud	A193 B7M	A320 L7M	A193 B8
29	Body Nut	A194 2HM	A194 4M	A194 8
30	Gear Stud	C.S.		
31	Gear Nut	C.S.		
32	Drain Valve	Zinc plated carbon steel		A276 316
33	Manual Gear	Commercial carbon steel		

1) \* Devlon is a registered trademark of the Devol Engineering company  
2) 304SS spiral wound graphite body-cap gasket

3) Applies only to 6" - 12" class 150 & class 300 valves  
4) 6" and larger valves are equipped with C.S + PTFE (DU) bearings

# ISV Series No. BT3BF Trunnion Mounted Ball Valves

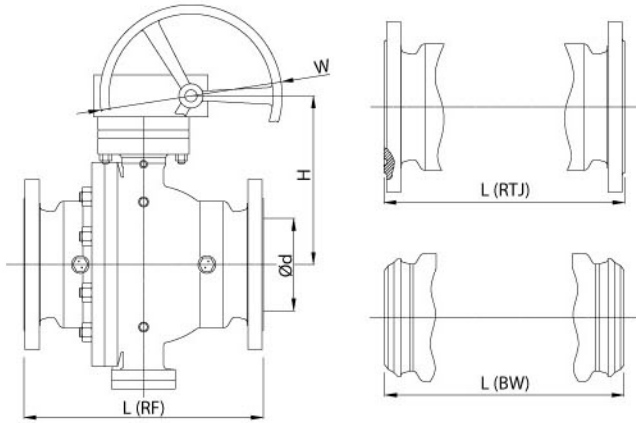

Working Pressures (psi)			
	Class 150	Class 300	Class 600
O-ring Seals:	HNBR	HNBR	HNBR
Seats Inserts:	RPTFE	RPTFE	Devlon
Min. Temp: -20 deg. F.	285	740	1480
Max. Temp: 300 deg. F.	230	500	1250

Pressure Test to API 6D (WCB)			
	Shell Test (Hydrostatic)	Seat Test (Hydrostatic)	Seat Test (Air)
Class 150	450 psi	313 psi	80 psi
Class 300	1125 psi	814 psi	80 psi
Class 600	2225 psi	1625 psi	80 psi

## Dimensions and Weight

Class 150										
Valve Size	NPS	2"	2 1/2"	3"	4"	6"	8"	10"	12"	
d	inch	2.00	2.50	3.00	4.00	6.00	8.00	10.00	12.00	
L (RF)	inch	7.00	7.50	8.00	9.00	15.50	18.00	21.00	24.00	
L (BW)	inch	8.50	9.50	11.13	12.00	18.00	20.50	22.00	25.00	
L (RTJ)	inch	7.50	8.00	8.50	9.50	16.00	18.50	21.50	24.50	
H	inch	6.00	6.50	7.63	8.40	10.90	12.60	15.56	18.13	
W *	inch	-	-	-	-	18.00	18.00	24.00	24.00	
WT (lbs)	RF	39.00	42.00	84.00	143.00	214.00	353.00	529.00	860.00	
	BW	33.00	38.00	77.00	121.00	205.00	340.00	501.00	805.00	

Class 300										
Valve Size	NPS	2"	2 1/2"	3"	4"	6"	8"	10"	12"	
d	inch	2.00	2.50	3.00	4.00	6.00	8.00	10.00	12.00	
L (RF)	inch	8.50	9.50	11.13	12.00	15.88	19.75	22.40	25.50	
L (BW)	inch	8.50	9.50	11.13	12.00	15.88	20.51	22.00	25.00	
L (RTJ)	inch	9.13	10.12	11.75	12.64	16.50	20.40	23.00	26.14	
H	inch	6.00	6.50	7.63	8.40	10.90	12.60	15.56	18.13	
W *	inch	-	-	-	-	18.00	18.00	24.00	24.00	
WT (lbs)	RF	40.00	60.00	104.00	176.00	260.00	441.00	805.00	1169.00	
	BW	31.00	49.00	84.00	143.00	232.00	408.00	754.00	1104.00	

Class 600										
Valve Size	NPS	2"	2 1/2"	3"	4"	6"	8"	10"	12"	
d	inch	2.00	2.50	3.00	4.00	6.00	8.00	10.00	12.00	
L (RF)	inch	11.50	13.00	14.00	17.00	22.00	26.00	31.00	33.00	
L (BW)	inch	11.50	13.00	14.00	17.00	22.00	26.00	31.00	33.00	
L (RTJ)	inch	11.63	13.13	14.13	17.13	22.13	26.13	31.14	33.13	
H	inch	7.00	6.50	7.70	8.40	10.70	13.50	19.50	22.88	
W *	inch	-	-	-	-	18.00	18.00	24.00	24.00	
WT (lbs)	RF	84.00	125.00	146.00	269.00	479.00	779.00	1565.00	2117.00	
	BW	69.00	113.00	128.00	258.00	441.00	721.00	1301.00	1742.00	

\* Gear operator hand wheel diameter

Distributed by | Distribuido por :



**ANYTHING**<sup>™</sup>  
**≈ FLOWS ≈**

[INFO@ANYTHINGFLOWS.COM](mailto:INFO@ANYTHINGFLOWS.COM)

[WWW.ANYTHINGFLOWS.COM](http://WWW.ANYTHINGFLOWS.COM)

**Flow Control , our passion ®**

**Life Flows on ™**



**SCAN ME**