

LEDEEN Actuators and Control Solutions

Innovative solutions for pneumatic, hydraulic, gas-over-oil, direct gas, and subsea applications

Contents

LEDEEN Actuators and Control Solutions

Introduction	3
Quarter-turn core products	
Configurations	4
Modular assembly	5
Frame design	6
Power cylinder and spring cartridge design	7
Override options and certifications	8
Core product types	
Quarter-turn pneumatic	9
Quarter-turn pneumatic	10
Quarter-turn hydraulic	11
Quarter-turn hydraulic subsea	12
Quarter-turn gas over oil	13
Quarter-turn direct gas	14
Linear core product types	
Linear pneumatic	15
Linear hydraulic	15
Linear gas over oil	16
Linear subsea	17
Controls and accessories	
Valve control board for pneumatic actuators	18
Pneumatic control manifold	19
Hydraulic self-contained controls	20
Hydraulic power unit	21
High-pressure gas controls	22
Electronic linebreak	23
Compact actuators	
Quarter turn pneumatic	24
Quarter turn hydraulic	25
Technology and quality	26
Services for valves and actuation	27

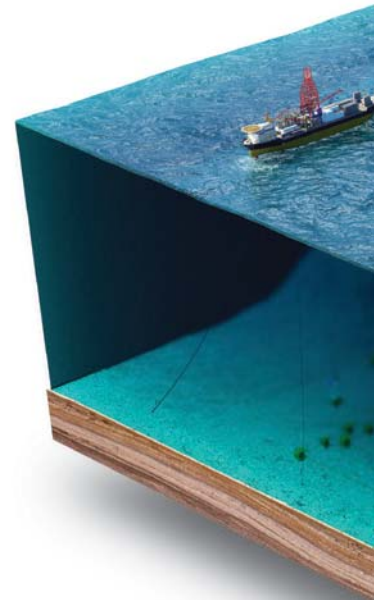

Introduction

Cameron LEDEEN* actuators and control solutions have consistently provided exceptional valve automation performance to the oil and gas industry since 1948, when we introduced a robust product design based upon solid engineering principles with a commitment to continuous improvement. Each successive year was guided by those foundational principles, enabling us to gain exposure to a wide range of operational conditions and to accumulate extensive first-hand application experience. This resulted in the ability to provide field-proven solutions that are known to be fit for purpose and reliable.

We obtained valuable product knowledge through years of successful operations in challenging desert, arctic, offshore, and subsea applications. Relying upon this extensive global experience and applying it during the evaluation of every requirement is a commitment to best practices that

benefits every customer working with Cameron. Whether requiring basic or complex valve automation, upstream to downstream, onshore to offshore, every application deserves the advantages that our LEDEEN actuators and control solutions can provide.

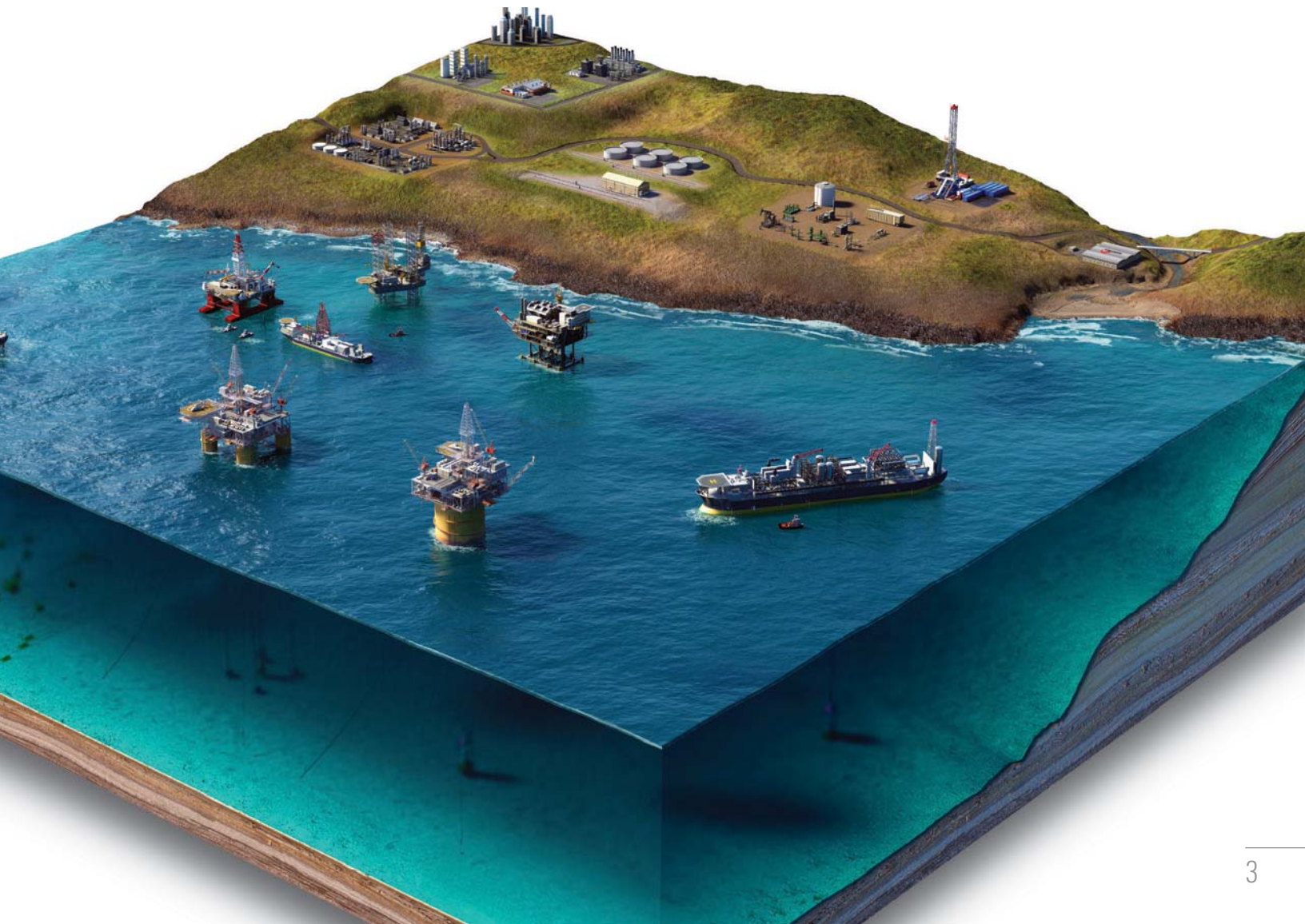

Quarter-Turn Core Products

Configurations

Pneumatic



Spring return.

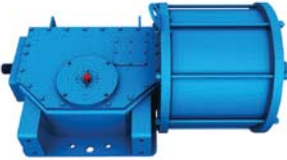

Double acting.

Hydraulic



Spring return.

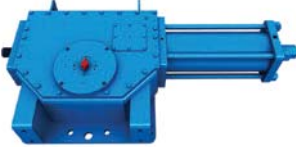

Double acting.

Gas Over Oil



Double acting.

Direct Gas

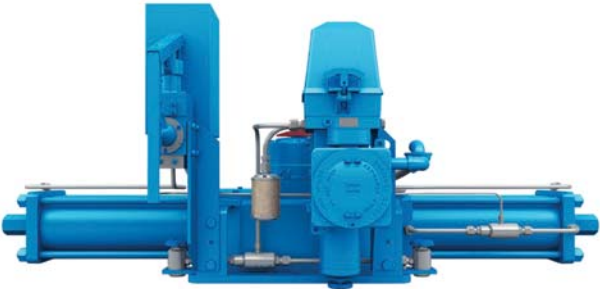

Double acting.

Modular Assembly

Consistent and flexible

Dependably high-quality engineering design and efficient modular assembly enables achieving increased operational flexibility. Double-acting, spring-return close-open, or manual override operations are readily obtainable on the low-pressure air, high-pressure gas or hydraulic products. This maintains product consistency throughout any project requirement,

regardless of valve size, class, actuator supply medium, pressure, or actuator function requirements. As a result, all products can be confidently operated by personnel. In addition, the consistent design provides a significant reduction in the quantity of recommended spare parts and seal kits, which reduces costs within maintenance programs.

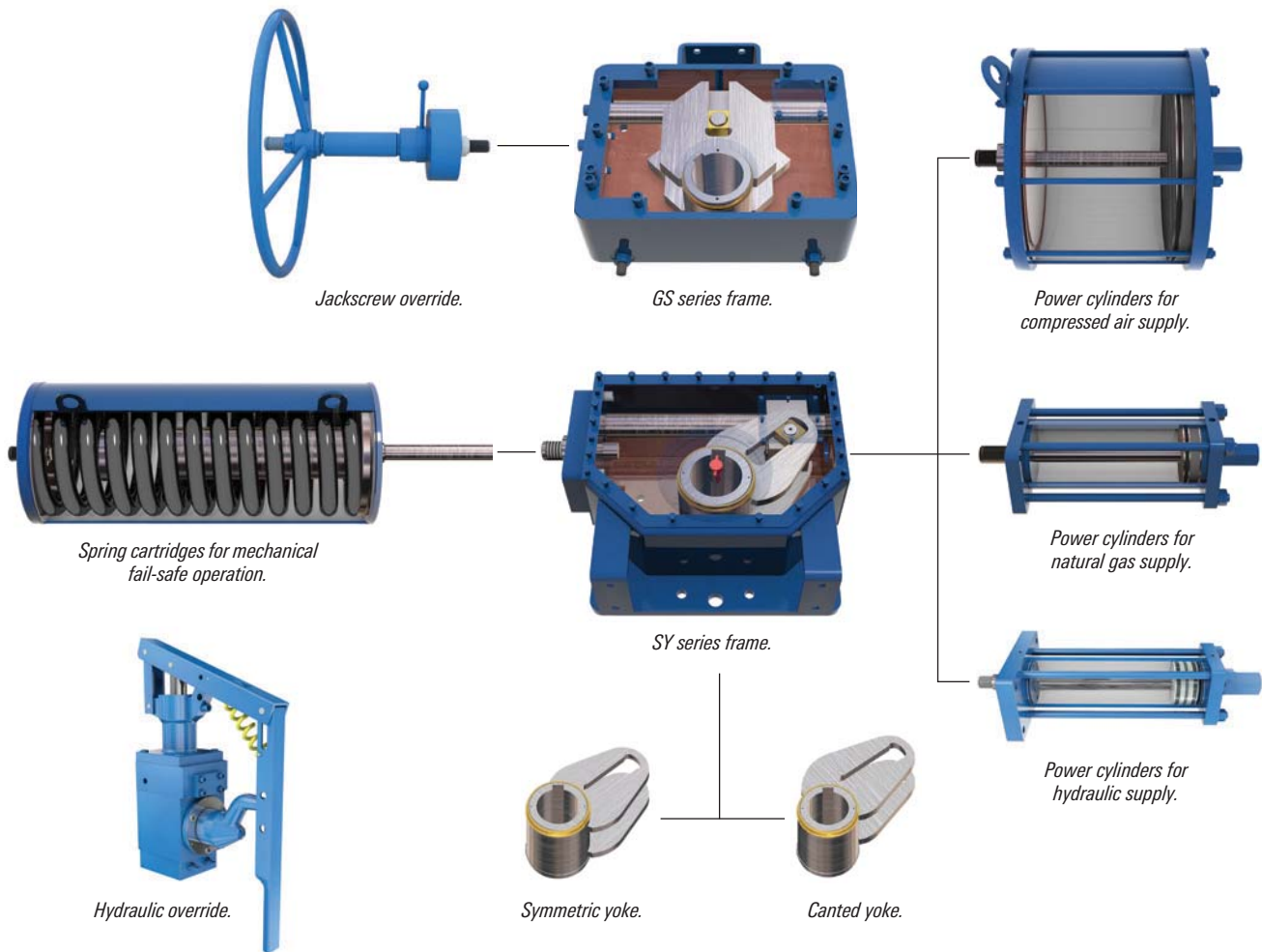

Frame Design

Standard features

- Scotch yoke mechanism that generates powerful opening and closing torque outputs
- Steel-fabricated frame for rugged foundation of modular assemblies
- Chrome-plated side load bar with guide block for effective elimination of piston rod deflection
- Bronze bushing interfaces that provide low-friction support of sliding and rotating components
- Aluminum bronze sliding blocks for a low-friction, low-stress pin connection

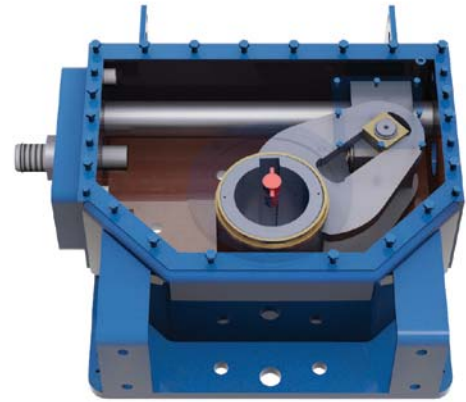

Fabricated frame.

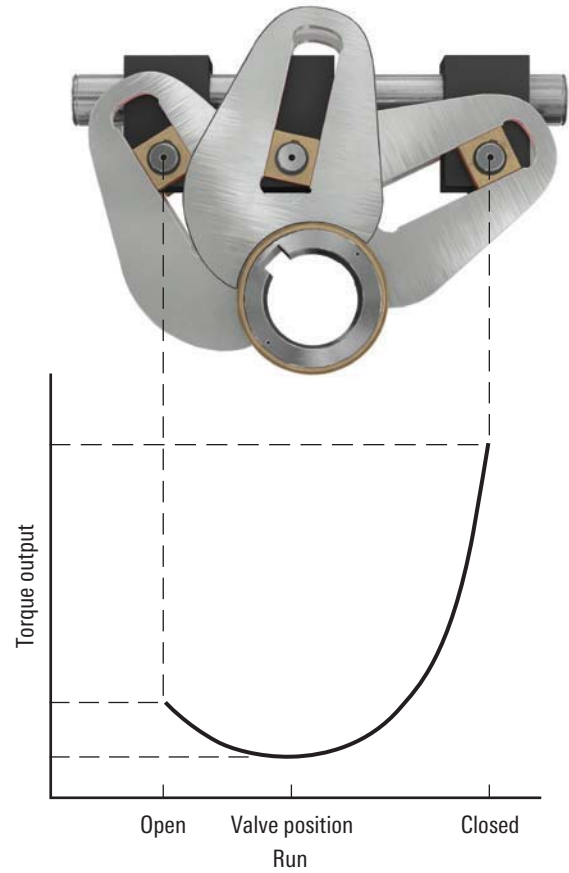
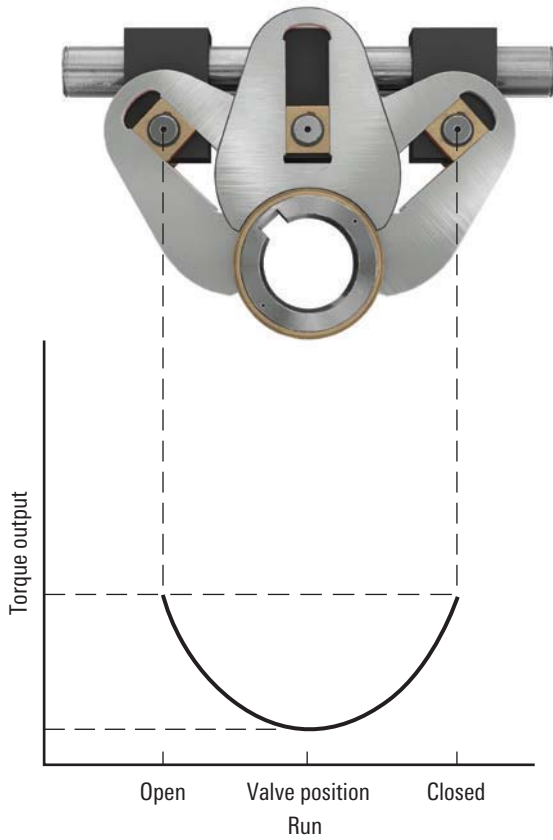

Symmetric yoke design

- Conventional torque output
- Equivalent break and end torque values

Canted yoke design

- Unique torque output
- Increased break and reset torque values

Power Cylinder and Spring Cartridge Design

Power cylinder standard features

- Steel cylinder assemblies, each designed specifically for the pressure containment of low-pressure compressed air, high-pressure gas, or high-pressure hydraulic supply mediums
- Nickel- or hard-chrome-plated cylinder ID that ensures excellent sealing surface with superior corrosion resistance
- Buna O-rings used for zero-leakage piston operation with a low-pressure supply medium; Buna quad rings used with a high-pressure gas or hydraulic supply medium
- Composite guide band on piston that provides low-friction guidance and support

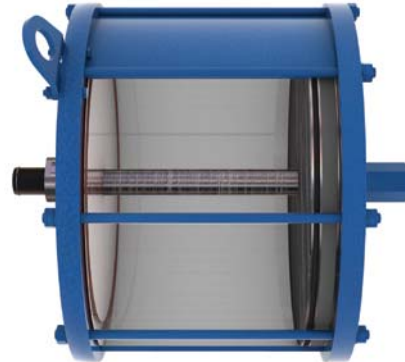

Power cylinders for compressed air supply.



Power cylinders for natural gas supply.

Spring cartridge standard features

- Steel spring cartridge that is fully enclosed from environmental conditions
- Epoxy-coated prestressed springs for consistent performance and corrosion protection
- Seal-welded design construction for increased personnel safety



Spring cartridges for mechanical fail-safe operation.

Standard Product Characteristics

Actuator series	GS and SY
Temperature range, degF [degC]	-22 to 212 [-30 to 100]
Pressure range (gauge), psi [bar]	40 to 3,000 [3 to 207]

Override Options and Certifications

- Jackscrew with handwheel for operating any double-acting or spring-return actuator through the SY10 model
- Hydraulic pump for easy operation of all actuator sizes and configurations
- Gear with handwheel that provides dual function of valve mounting hardware with override capability for any model of double-acting or spring-return actuator



Pneumatic spring return with jackscrew override.



Pneumatic double acting with jackscrew override.



Pneumatic double acting with hand pump override.

Certifications

LEDEEN actuators comply with many industry standards:

- ISO 9001:2008
- PED 97/23/CE 2002
- SI 825, 1996
- IEC 61508:2010
- Technical Regulations Customs Union.



ISO 9001:2008

ISO 9001:2008 quality management system.



PED 97/23/EC

European PED.



IEC 61508:2010

SIL-3 capability.

Core Product Types

Quarter-Turn Pneumatic

Typical application

Quarter-turn pneumatic actuators are used for on-off or modulating control of any ball, plug, or butterfly valve using compressed air, natural gas, or nitrogen actuator supply.

Standard features

- All models available as double acting or spring return
- Torque outputs to 5,700,000 in.lbf [644,000 N.m]
- Open and close travel stops, $\pm 3^\circ$ minimum
- Local position indication
- Suitable for SIL-3 environments

Available options

- Jackscrew, hydraulic, and gear overrides
- Mechanical partial stroke test device (local or remote operation)
- Spring-return direct-gas configurations with hydraulic dampening
- Special seals for low-temperature applications to -76 degF [-60 degC] and for high-temperature applications to 392 degF [200 degC]

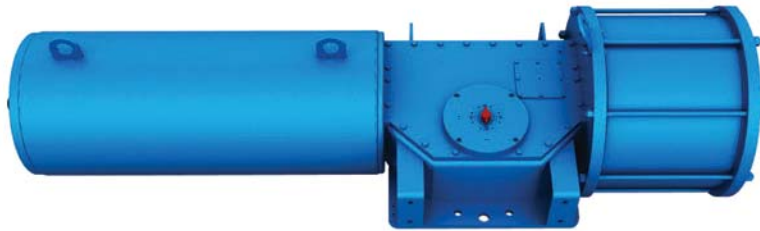

Quarter-turn pneumatic.

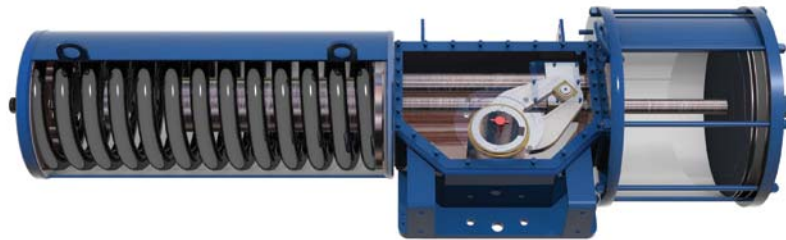

Pneumatic spring return.

Standard Product Characteristics

Actuator series	GS and SY
Temperature range, degF [degC]	-22 to 212 [-30 to 100]
Pressure range (gauge), psi [bar]	40 to 175 [3 to 12]

Quarter-Turn Pneumatic

Typical application

Quarter-turn pneumatic actuators are used for on-off or modulating control of any ball, plug, or butterfly valve using compressed air, natural gas, or nitrogen actuator supply.

Standard features

- Available as double acting or spring return
- Torque outputs to 9,700 in.lbf [1,100 N.m]
- Forged steel body, piston, and end caps
- Steel cylinders with nickel-plated ID
- Symmetric yoke
- Aluminum bronze sliding blocks in yoke
- Composite guide sleeve on piston
- Open and close travel stops, $\pm 3^\circ$ minimum
- Local position indication
- Suitable for SIL-3 environments

Available options

- Stainless steel cylinders
- Spring-return direct-gas configurations with hydraulic dampening
- Jackscrew with handwheel for operating any double-acting or spring-return model
- Gear with handwheel that provides dual function of valve mounting hardware with override capability for any double-acting or spring-return model
- Special seals for low-temperature applications to -76 degF [-60 degC] and for high-temperature applications to 392 degF [200 degC]



Quarter-turn pneumatic.

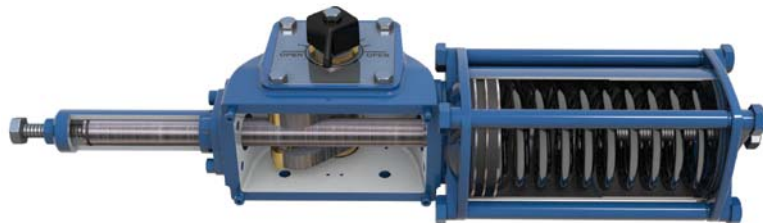

Pneumatic spring return.

Standard Product Characteristics

Actuator series	VA
Temperature range, degF [degC]	-22 to 212 [-30 to 100]
Pressure range (gauge), psi [bar]	40 to 175 [3 to 12]

Quarter-Turn Hydraulic

Typical application

Quarter-turn hydraulic actuators are used for on-off or modulating control of any ball, plug, or butterfly valve using hydraulic actuator supply.

Standard features

- All models available as double acting or spring return
- Torque outputs to 5,700,000 in.lbf [644,000 N.m]
- Open and close travel stops, $\pm 3^\circ$ minimum
- Local position indication
- Suitable for SIL-3 environments

Available options

- Jackscrew, hydraulic, and gear overrides
- Mechanical partial stroke test device (local or remote operation)
- Spring-return direct-gas configurations with hydraulic dampening
- Special seals for low-temperature applications to -76 degF [-60 degC] and for high-temperature applications to 392 degF [200 degC]



Quarter-turn hydraulic.



Hydraulic spring return.

Standard Product Characteristics

Actuator series	GS and SY
Temperature range, degF [degC]	-22 to 212 [-30 to 100]
Pressure range (gauge), psi [bar]	145 to $3,000$ [10 to 207]

Quarter-Turn Hydraulic Subsea

Deepwater Series

Typical application

For on-off control of any subsea ball, plug, or check valve in a submerged environment beyond 500-ft [152-m] water depth.

Standard features

- Available as double acting or spring return
- Torque outputs to 3,600,000 in.lbf [400,000 N.m]
- Scotch yoke mechanism
- Pressure compensation for deep applications
- 100% radiographically and penetrant-tested (RX and PT) welds
- No external tie rods
- Open and close travel stops, $\pm 5^\circ$ minimum
- Local tactile position indicator
- Spool piece with adjustable position locators

Available options

- Manual override
- ROV override
- Microswitch for open-close indication
- Position transmitter for 0% to 100% travel indication



Deepwater series.

Shallow-Water Series

Typical application

For on-off control of any quarter-turn-operated valve in a submerged environment to 500-ft [152-m] water depth.

Standard features and benefits

- Available as double acting or spring return
- Torque output to 5,700,000 in.lbf [644,000 N.m]
- Open and close travel stops provide $\pm 3^\circ$ minimum
- Scotch yoke mechanism
- Buna piston seal
- Composite guide band on piston
- Epoxy-coated springs
- Pressure compensator

Available options

- Manual override
- ROV override
- Microswitch for open-close indication
- Position transmitter for 0% to 100% travel indication



Shallow-water series.

Standard Product Characteristics

Actuator series	Deepwater	Shallow-water
Submersion [water depth], ft [m]	>500 [152]	≤ 500 [152]
Pressure range (gauge), psi [bar]	150 to 3,000 [10 to 207]	150 to 3,000 [10 to 207]

Quarter-Turn Gas Over Oil

Typical application

Quarter-turn gas-over-oil actuators are used for on-off control of any natural gas transmission ball or plug valve using a high-pressure natural gas or nitrogen actuator supply.

Standard features

- All models available as double acting
- Torque outputs to 5,700,000 in.lbf [644,000 N.m]
- Open and close travel stops, $\pm 3^\circ$ minimum
- Local position indication
- American Society of Mechanical Engineers (ASME) Pressure Equipment Directive (PED) gas-over-oil pressure vessels with dipstick, filter, and adjustable speed controls
- High-pressure-rated controls for local, remote, and automatic operation
- Hydraulic manual override
- Suitable for SIL-3 environments

Available options

- Spring-return direct-gas configurations with hydraulic dampening
- ASME PED emergency storage tank
- Special seals for low-temperature applications to -76 degF [-60 degC] and for high-temperature applications to 392 degF [200 degC]

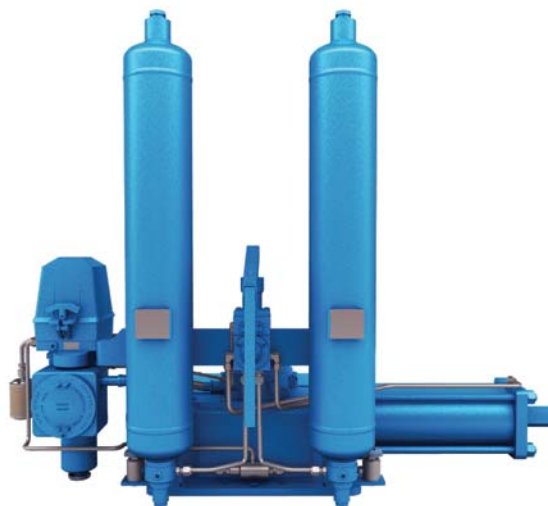

Quarter-turn gas over oil.

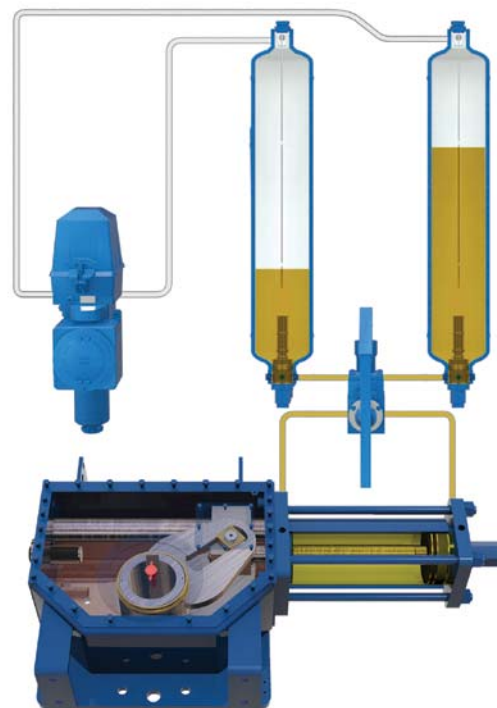

Operational diagram.

Standard Product Characteristics

Actuator series	GS and SY
Temperature range, degF [degC]	-22 to 212 [-30 to 100]
Pressure range (gauge), psi [bar]	145 to $1,500$ [10 to 103]

Quarter-Turn Direct Gas

Typical application

Quarter-turn direct gas actuators are used for on-off control of any natural gas transmission ball or plug valve using a high-pressure natural gas or nitrogen actuator supply.

Standard features

- All models available as double acting
- Torque outputs to 5,700,000 in.lbf [644,000 N.m]
- Open and close travel stops, $\pm 3^\circ$ minimum
- Local position indication
- Hydraulic manual override with reservoir filter, dipstick, and adjustable speed controls
- High-pressure-rated controls for local, remote, and automatic operation
- Suitable for SIL-3 environments

Available options

- Spring-return direct-gas configurations with hydraulic dampening
- ASME PED emergency storage tank
- Spring-return models
- Special seals for low-temperature applications to -76 degF [-60 degC] and for high-temperature applications to 392 degF [200 degC]

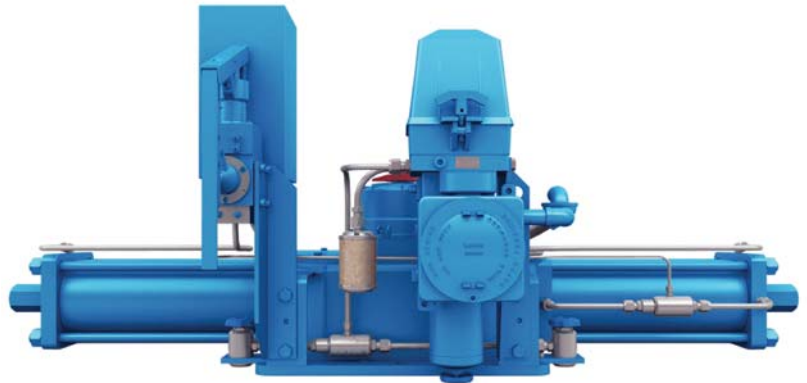

Quarter-turn direct gas.

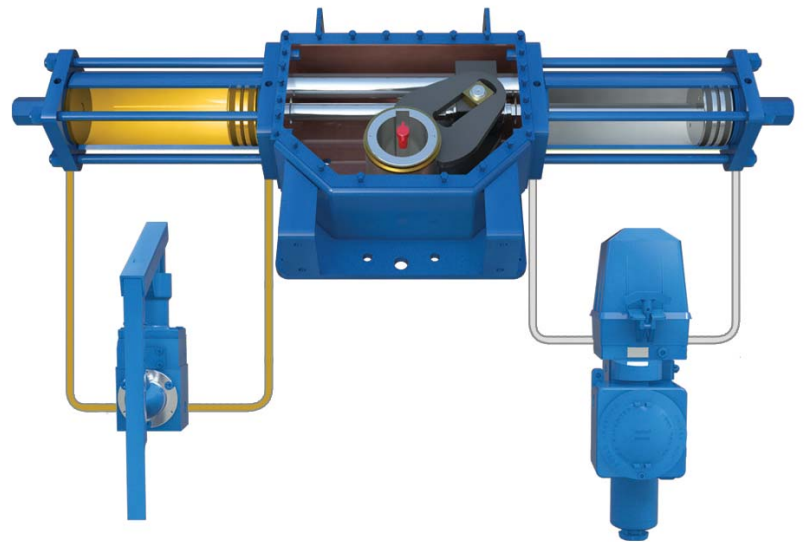

Operational diagram.

Standard Product Characteristics

Actuator series	GS and SY
Temperature range, degF [degC]	-22 to 212 [-30 to 100]
Pressure range (gauge), psi [bar]	145 to 1,500 [10 to 104]

Linear Core Product Types

Linear Pneumatic (LP)

Typical application

Linear pneumatic actuators are used for on-off control of any gate valve or rising stem ball valve using compressed air, natural gas, or nitrogen actuator supply.

Piston actuator standard features

- All models available as double acting or spring return
- Thrust outputs to 4,400,000 lbf [19,600,000 N]
- Local position indication
- Suitable for SIL-3 environments

Available options

- Mechanical jackscrew override
- Hydraulic manual override
- Spring-return direct-gas configurations with hydraulic dampening
- Special seals for low-temperature applications to -76 degF [-60 degC] and for high-temperature applications to 392 degF [200 degC]



Linear pneumatic.

Linear Hydraulic (LH)

Typical application

Linear hydraulic actuators are used for on-off control of any gate valve or rising stem ball valve using a hydraulic actuator supply.

Standard features

- All models available as double acting or spring return
- Thrust outputs to 4,400,000 lbf [19,600,000 N]
- Local position indication
- Suitable for SIL-3 environments

Available options

- Mechanical jackscrew override
- Hydraulic manual override
- Spring-return direct-gas configurations with hydraulic dampening
- Operating pressure (gauge) to 5,000 psi [345 bar]
- Special seals for low-temperature applications to -76 degF [-60 degC] and for high-temperature applications to 392 degF [200 degC]

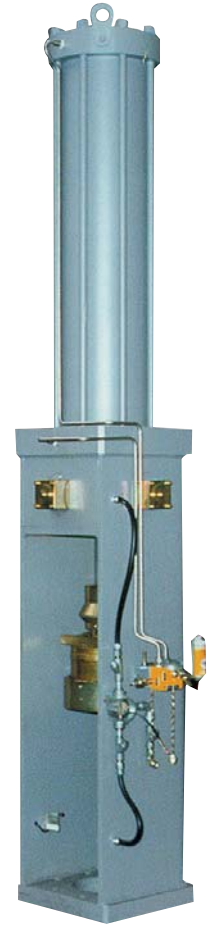

Linear hydraulic.

Standard Product Characteristics

Actuator series	LP	LH
Temperature range, degF [degC]	-22 to 212 [-30 to 100]	-22 to 212 [-30 to 100]
Pressure range (gauge), psi [bar]	40 to 175 [3 to 12]	145 to 3,000 [10 to 207]

Linear Gas Over Oil

Typical application

Linear gas-over-oil actuators are used for on-off control of any natural gas transmission gate valve using a high-pressure natural gas or nitrogen actuator supply.

Piston actuator standard features

- Available as double acting
- Thrust outputs to 4,400,000 lbf [19,600,000 N]
- Local position indication
- ASME PED gas-over-oil pressure vessels with dipstick, filter, and adjustable speed controls
- High-pressure-rated controls for local, remote, and automatic operation
- Hydraulic manual override
- Suitable for SIL-3 environments

Available options

- Spring-return direct-gas configurations with hydraulic dampening
- ASME PED emergency storage tank
- Special seals for low-temperature applications to -76 degF [-60 degC] and for high-temperature applications to 392 degF [200 degC]



Linear gas over oil.

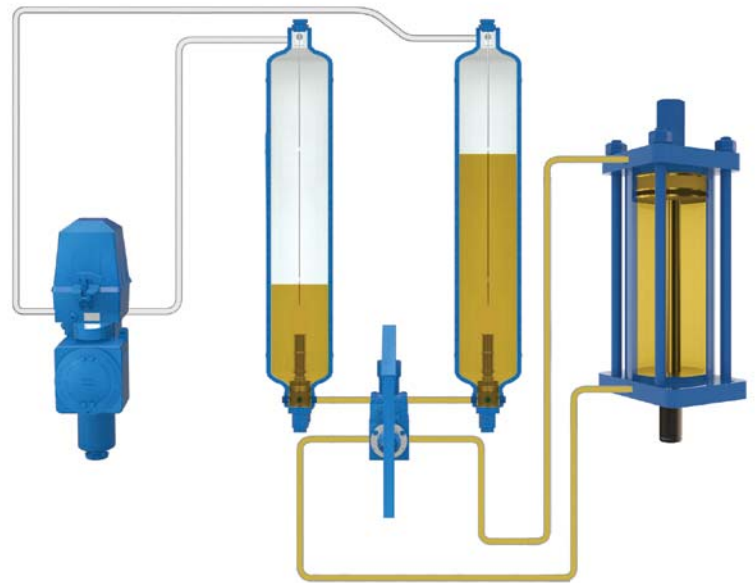

Operational diagram.

Standard Product Characteristics

Actuator series	LH-GH
Temperature range, degF [degC]	-22 to 212 [-30 to 100]
Pressure range (gauge), psi [bar]	145 to 1,500 [10 to 103]

Linear Subsea

Typical application

Linear subsea actuators are used for on-off control of any subsea gate valve using a hydraulic actuator supply.

Standard features

- Available as double acting or spring return
- Thrust outputs to 4,400,000 lbf [19,600,000 N]
- Pressure compensation for deep applications
- 100% RX and PT welds
- No external tie rods or tubing

Available options

- ROV override
- Diver intervention
- In-house hyperbaric testing



Linear gas over oil.

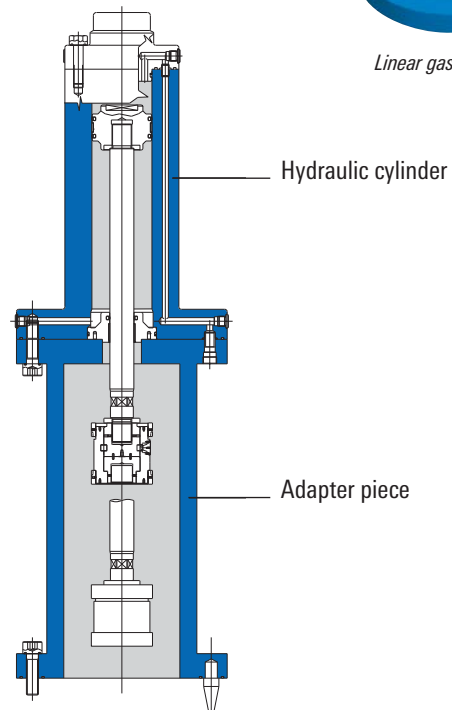

Standard Product Characteristics

Actuator series	Mytilus
Pressure range (gauge), psi [bar]	150 to 3,000 [10 to 207]

Controls and Accessories

Valve Control Board for Pneumatic Actuators

Designed using in-field, real-world problem solving and keeping serviceability in mind, this valve control board (VCB) offers one of the highest levels of reliability and safety on the market today. The system has been developed to provide a turnkey control panel for the most common logics used for on-off valves in oil and gas applications. The VCB for pneumatic LEDEEN actuators is capable of a variety of operations, including increased flow capacities and suite operation requests on stroking time on a wide range of actuators.

Technical data

Panel

Control system components are mounted on a stainless steel (SS) 316 panel complete with a sunshade

Dimensions

- Fail-open and fail-closed schematics for spring-return actuators: 18 in × 16 in × 10 in [450 mm × 400 mm × 250 mm]
- Stay-put schematics for double-acting actuators: 22 in × 18 in × 10 in [550 mm × 450 mm × 250 mm]

Mounting options

- On board (panel mounted directly to LEDEEN actuator)
- On 2-in pole (mounting kit separately delivered on request)
- Wall mounted (mounting kit separately delivered on request)

Tubing and fittings

- Tubing: SS 316L—imperial size (metric available on request)
- Fittings: SS 316 double ferrule type (Swagelok® fittings)



VCB for pneumatic LEDEEN actuators.



VCB mounted onboard.

Standard Product Characteristics

Control models	VCB
Temperature range, degF [degC]	−40 to 200 [−40 to 93]
Pressure range (gauge), psi [bar]	0 to 175 [0 to 12]

Pneumatic Control Manifold

Typical application

Low-pressure pneumatic controls are used for local, remote, or automatic control of any low-pressure pneumatic actuator.

Standard features

- Compact manifold design
- 316 stainless steel construction
- High flow capacity
- Accommodation of multiple solenoid brands
- Approval to NEMA and Atmosphères Explosibles (ATEX) standards
- Control of double-acting and spring-return actuators
- Adaptability for custom applications
- FKM fluorocarbon Viton® seals
- SIL-3 environment suitability

Available options

- Pilot or electrical control signal
- ASCO®, Midland®, or Versa® solenoid
- Lever or palm button manual operator
- Latching detent and manual reset devices
- Low power consumption
- Ethylene propylene diene monomer (EPDM) seals for low-temperature applications



Pneumatic control manifold.

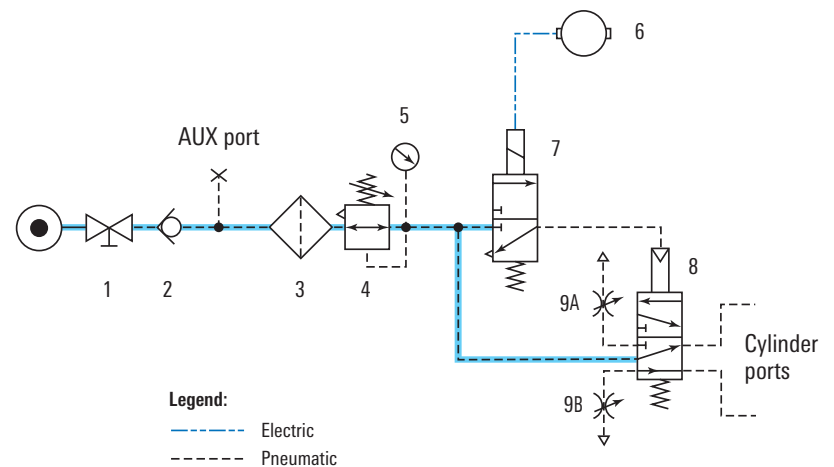

Item	Description
1	Lockable stop valve
2	Check valve
3	Filter
4	Pressure regulator
5	Pressure gauge

Item	Description
6	Junction box
7	Solenoid valve
8	Pneumatic piloted valve
9A, 9B	Flow control valve

Standard Product Characteristics

Control models	Local, remote, or automatic
Temperature range, degF [degC]	-40 to 200 [-40 to 93]
Pressure range (gauge), psi [bar]	0 to 175 [0 to 12]

Hydraulic Self-Contained Controls

Typical application

Hydraulic self-contained controls are used for providing a reliable valve shutdown capability when an external power source for the actuator is either not available or not dependable.

Standard features

- Models available with 3,000- and 5,000-psi gauge pressure outputs
- Corrosion-resistant anodized aluminum with stainless steel internals
- Manual arming valve with bright-red-colored local emergency shutdown (ESD) trip function
- Thermal compensation for high- and low-pressure circuits
- Independently adjustable pilot valves for pressure sensor high (PSH) and pressure sensor low (PSL)
- Stainless steel pressure gauges for high- and low-pressure circuits
- Easy-view liquid level gauge attached to stainless steel reservoir

Available options

- Low power consumption solenoid for remote trip
- Lockable stainless steel enclosure
- Fusible plug

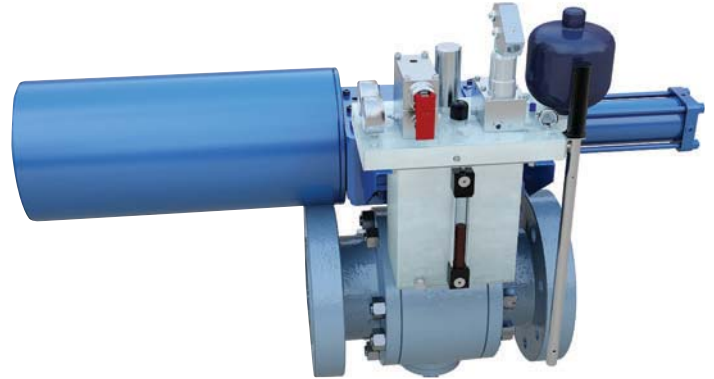

Typical self-contained assembly.



Self-contained control.

Standard Product Characteristics

Control models	Self-contained
Temperature range, degF [degC]	-50 to 212 [-45 to 100]
Pressure range (gauge), psi [bar]	3,000 to 5,000 [207 to 345]

Hydraulic Power Unit

Typical application

The hydraulic power unit provides a reliable high-pressure hydraulic output as a power source for hydraulic actuators.

Electric motor operated

- Available for mounting on the actuator or remotely

Centralized

- Simultaneous generation of power for a large quantity of actuators
- Centralized hydraulic controls for all actuators

Portable gasoline or diesel operated

- Mobile power source for individual actuator requirements
- Flexible hoses with quick disconnects

Solar operated

- Accommodation of single or multiple actuator requirements
- Completely self-contained
- Emergency storage capability

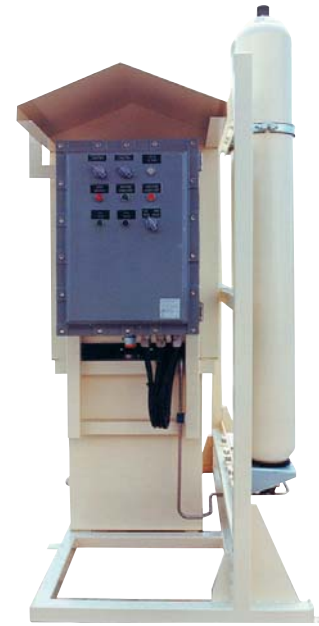

Remote-mounted, electric-motor-operated unit.

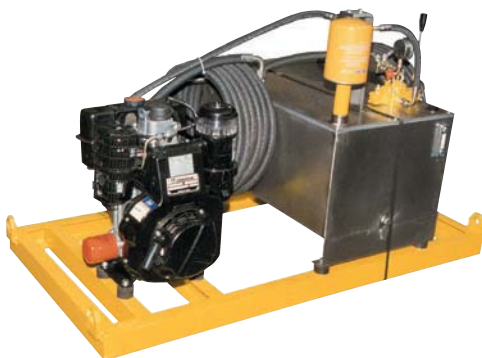

Portable gasoline-operated unit.



Solar-operated unit.

Standard Product Characteristics

Power units	Electric, gasoline, diesel, or solar
Temperature range, degF [degC]	-40 to 212 [-40 to 100]
Pressure range (gauge), psi [bar]	145 to 3,000 [10 to 207]

High-Pressure Gas Controls

Typical application

High-pressure gas controls are used for local, remote, or automatic control of any high-pressure gas actuator using a natural gas or nitrogen supply.

Standard features

- Compact design with weatherproof enclosure
- All components have high pressure rating
- Three-stage gas filter and conditioner
- Easy operation of manual levers throughout pressure range
- Durable marine-grade materials
- Ability to convert from local to remote or automatic operation

Available options

- Electric remote
- Electric fail safe
- ESD
- High- and low-pressure shutdown
- Linebreak (diaphragm, digital, or electronic)
- Station bypass
- Various configurations or special requirements



Local remote control.



Local remote with linebreak detection control.

Standard Product Characteristics

Control models	Local, remote, or automatic
Temperature range, degF [degC]	-76 to 212 [-60 to 100]
Pressure range (gauge), psi [bar]	145 to 1,500 [10 to 103]

Electronic Linebreak

Typical application

Electronic linebreak controls are used for monitoring pipeline operating conditions to quickly detect pressure trending toward abnormally high or low rate-of-drop values and accurately monitor those trends for an automatic shutdown response when preestablished set points are reached.

Standard features

- Continuous pipeline pressure monitoring and data acquisition
- Initiates valve closure when PSH, PSL, or rod limits are reached
- Canadian Standards Association certified for Class 1, Div. 2 hazardous locations
- Weather-tight NEMA 4 enclosure that supports integral battery
- Enclosure that allows mounting of single- or dual-pressure transmitters
- User-assignable data for local display on large-character LCD screen
- RS-232 and RS-485 communication connections

Available options

- Solar power (panel with all associated circuit accessories)
- Dual-pressure transmitters for redundancy or dynamic positioning monitoring
- Expansion board for additional I/O connections



Electrical linebreak control.

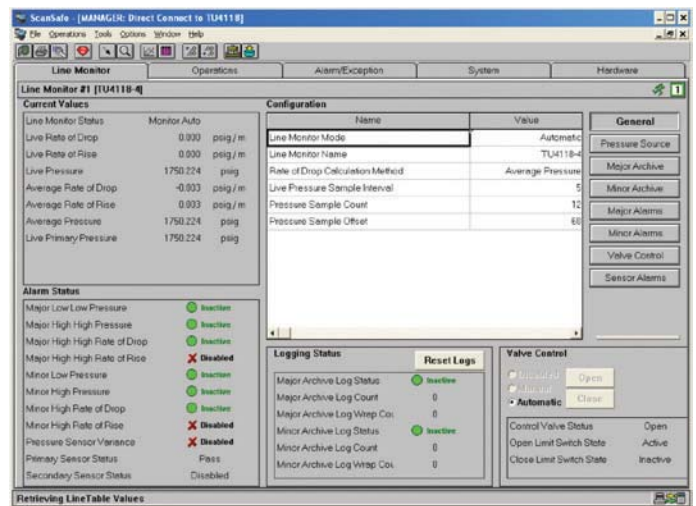

Line monitor screen display.

Standard Product Characteristics

Control models	Safemaster® system
Temperature range, degF [degC]	-40 to 140 [-40 to 60]
Pressure range (gauge), psi [bar]	Pressure transmitter dependent

Compact Actuators

Quarter-Turn Pneumatic

Typical applications

The compact pneumatic LEDEEN actuator is a quarter-turn actuator ideal for space-constrained installations, including

- FPSO vessels and platforms
- offloading buoys and manifolds
- ESD and high-integrity pressure protection system.

Standard features

- Available double-acting or spring return designs
- Torque outputs to 283,000 in.lbf [32,000 N.m]
- Open and close travel stops provide $\pm 3^\circ$ minimum adjustment
- Helical slot torque-generating mechanism
- Roller transfer of thrust
- Rugged carbon steel frame
- Electroless nickel-plated pneumatic cylinder bore with polytetrafluoroethylene guide band
- Buna piston seals
- Totally enclosed spring cartridge
- Epoxy-coated springs
- Local position indicator
- Adaptability to any quarter-turn valve topworks
- Radio frequency identification (RFID) tag for positive identification and life-of-product tracking

Available options

- Gearbox override
- Mechanical partial stroke test device (local or remote operation)
- Special seals for low-temperature applications to -76 degF [-60 degC]



Pneumatic double-acting actuator.

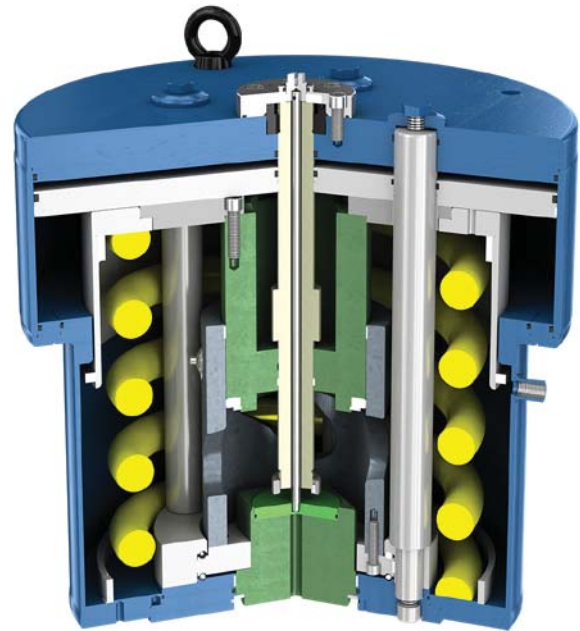

Pneumatic spring-return actuator.

Standard Product Characteristics

Actuator model	CP
Temperature range, degF [degC]	-22 to 185 [-30 to 85]
Gauge pressure range, psi [bar]	40 to 160 [3 to 11]

Quarter-Turn Hydraulic

Typical applications

The compact hydraulic LEDEEN actuator is a quarter-turn actuator ideal for space-constrained installations, including

- FPSO vessels, platforms, and offloading buoys
- drilling diverters
- carbon dioxide and liquid mainlines
- mining operations.

Standard features

- Available as double acting or spring return
- Torque outputs to 340,000 in.lbf [38,400 N.m]
- Open and close travel stops provide $\pm 3^\circ$ minimum adjustment
- Helical spline torque-generating mechanism
- Low-friction spline treatment
- Rugged alloy steel frame
- Buna piston seals
- Fully welded spring cartridge subassembly
- Epoxy-coated springs
- Local position indicator
- Adaptability to any quarter-turn valve topworks
- RFID tag for positive identification and life-of-product tracking

Available options

- Hand pump or gearbox overrides
- Mechanical partial stroke test device (local or remote operation)
- Special seals for low-temperature applications to -76 degF [-60 degC]



Hydraulic double acting actuator.



Hydraulic spring return actuator.

Standard Product Characteristics

Actuator model	HS
Temperature range, degF [degC]	-22 to 185 [-30 to 85]
Gauge pressure range, psi [bar]	145 to 3,000 [10 to 207]

Technology and Quality

As an established leader in actuation technology, Cameron offers a complete line of actuation and control solutions across a range of flow control applications.

Through technological advancements, LEDEEN actuators deliver a range of capabilities, power, and performance in both quarter-turn and linear configurations.

For local, remote, or automatic operation, the Cameron portfolio of LEDEEN actuators features innovative products with intelligent actuation technology designed for some of the world's most demanding applications.

Specialized equipment

- To verify performance in actual subsea working conditions, LEDEEN actuators go through stringent hyperbaric testing procedures in simulated environments to ensure all products meet and exceed industry standards.
- Cameron has the capability to validate LEDEEN actuator torque output to 13,300,000 in.lbf [1,500,000 N.m].

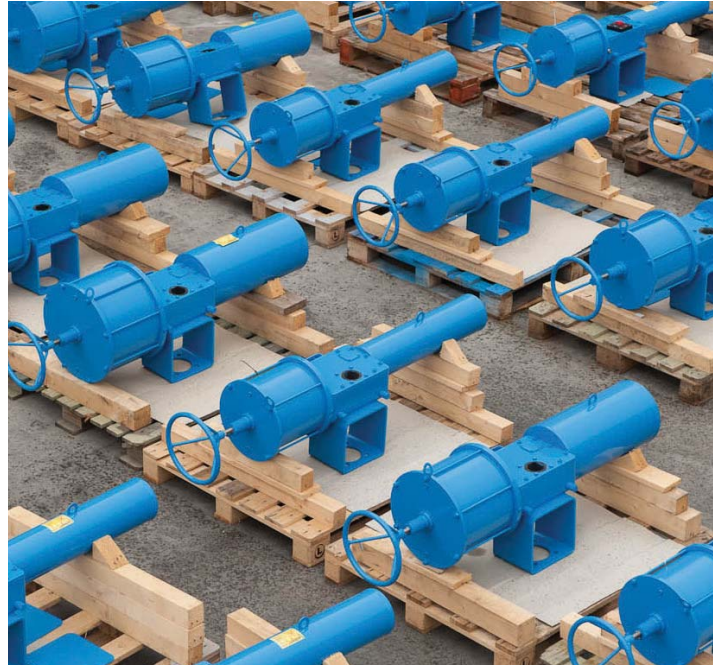

Services for Valves and Actuation

Cameron is well positioned to quickly and efficiently deliver total aftermarket support with unmatched original equipment manufacturer expertise. Our highly skilled engineers and technicians are available around the clock to respond to customer queries, troubleshoot problems, and offer reliable solutions.

Easily accessible parts and spare valves

- OEM spare valves, actuators, and parts (including non-Cameron brands)
- Handling, storage, packaging, and delivery
- Dedicated stocking program

Comprehensive services portfolio

- Parts and spare valves
- Repair
- Field services
- Preventive maintenance
- Equipment testing and diagnostics
- Remanufacturing
- Asset preservation
- Customer property management
- Training and recertification services
- Warranty

Customized total valve care programs

- Engineering consultancy
- Site management
- Flange management
- Startup and commissioning
- Spare parts and asset management
- Operational support



LEDEEN Actuators and Control Solutions

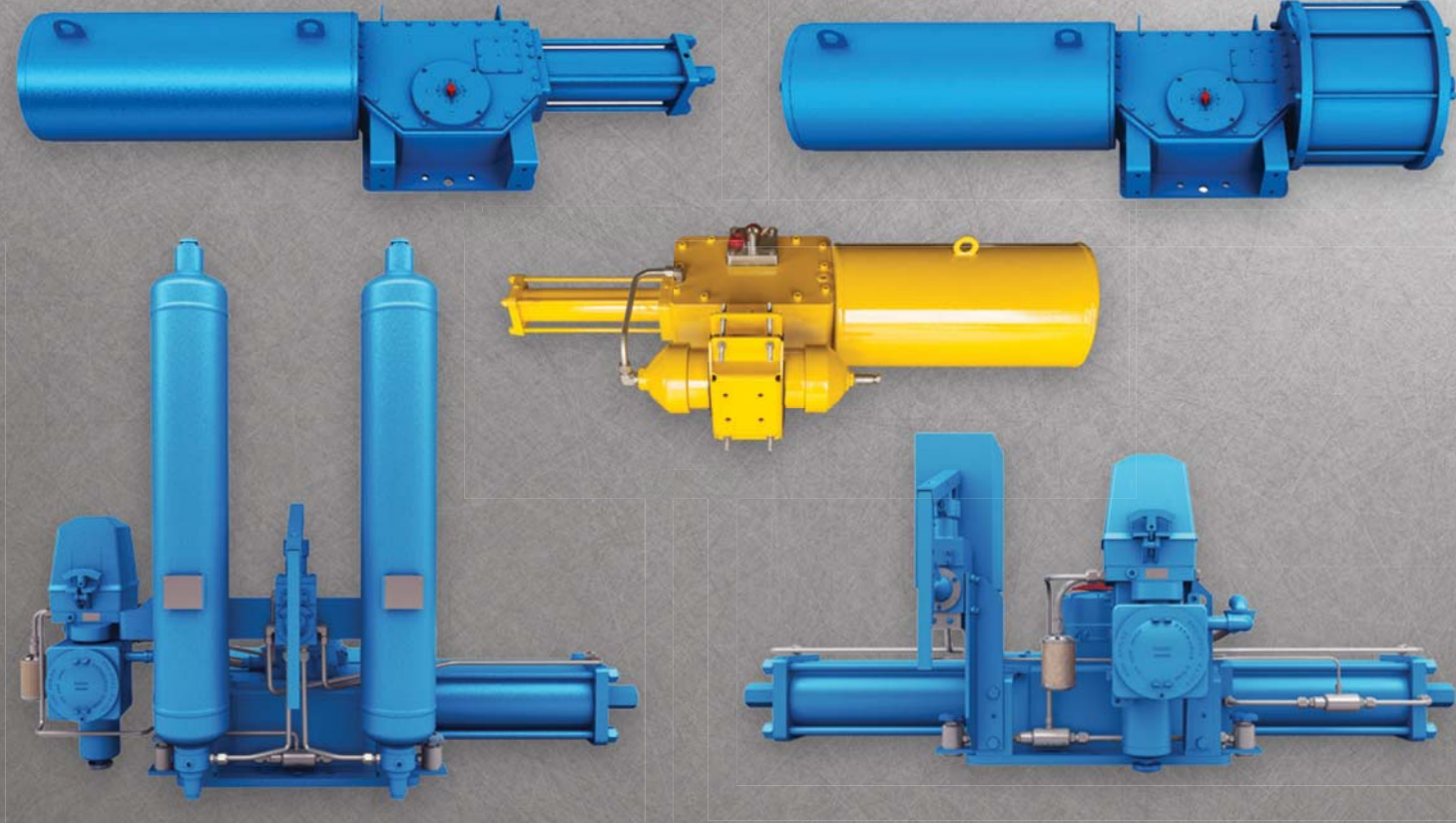

Distributed by | Distribuido por :



ANYTHINGTM
≈ FLOWS ≈

INFO@ANYTHINGFLOWS.COM

WWW.ANYTHINGFLOWS.COM

Flow Control , our passion ®

Life Flows on TM



SCAN ME