



Emergency Shut Down & Linebreak Protection

***We take on the most
critical applications.***

That's our business!

***Exceptional reliability
with minimal
maintenance***



Applications

Emerson – Actuation Technologies is recognized worldwide for the reliability of its actuators under the most demanding conditions. The Shafer™ RV-Series rotary vane actuator was specifically designed for pipeline applications where rugged dependability of equipment is vital.

Shafer rotary vane actuators are used to automate ball valves or plug valves in all types of severe climatic conditions. Over the last 60 years, more than 100,000 rotary vane actuators have been successfully installed on various kinds of pipelines, and most of the actuators are still in operation.

- Full open/close operation of ball valves and plug valves
- Automation of valves on natural gas pipelines where the actuators are typically powered by natural gas using gas-over-oil technology
 - Emergency Shut Down
 - Mainline isolation
 - Linebreak protection
 - Station blow down
 - Remote valve control
 - Hi/low pressure shutoff
 - River crossings
- The rotary vane's compact size and concentric weight distribution make it ideal for high vibration applications
 - Slurry pipelines
 - Pump and compressor stations
- Valve automation for crude oil or refined products pipelines with precise control of the stroking speed

Capabilities

- Torque output range:
1,000 lbf-in to 17.8 million lbf-in
(113 Nm to 2.0 million Nm)
- Power supply pressure range:
200 psi (13.8 bar) minimum, up to 3,000 psi (206.8 bar)
on various models
- Ambient temperature range:
-20°F to 250°F (-29°C to 121°C) Standard
-50°F to 250°F (-46°C to 121°C) Optional
-76°F to 250°F (-60°C to 121°C) Consult Factory

Capabilities



The rotary vane is a hydraulic powered actuator. Hydraulic force simultaneously forces both of the rotor's vanes away from the stationary shoes producing rotation and perfectly balanced torque output. Hydraulic input power is reversed for rotation in the opposite direction.

There is no conversion of linear to rotary motion, so this highly efficient actuator design produces perfectly balanced torque.

The rotary vane actuator models an ideal torque couple. The resultant force vectors acting on the vanes are always perpendicular to the vane surface. The two opposing forces form a torque couple which is the most efficient method of producing rotation.

The balanced torque output of the rotary vane actuator will not produce any destructive side loading forces that could be transmitted to the valve stem or the actuator's bearings.

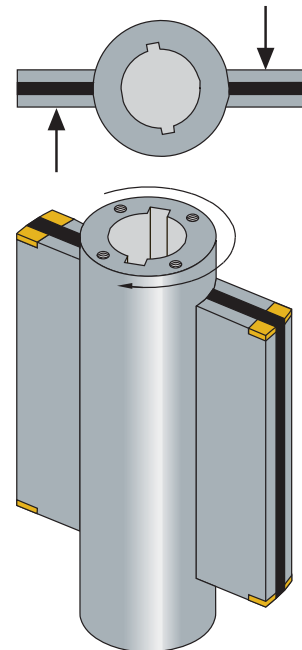

TORQUE OUTPUT PROFILE

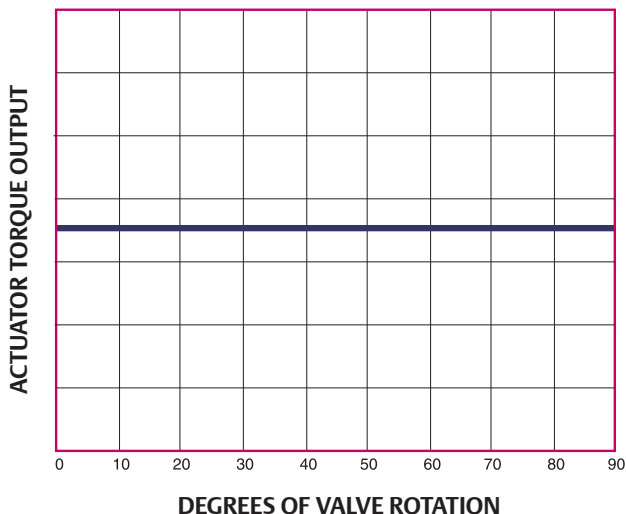

Torque output of the rotary vane actuator remains constant throughout the full rotation of the valve. This ensures that your specified safety factor will not be jeopardized at different positions during the valve stroke. Constant torque output is an especially important feature in the following applications:

- Potentially high flow applications like blow down and line break
- Plug valves or metal to metal seated valves
- Ball valves with rotating seats

Construction

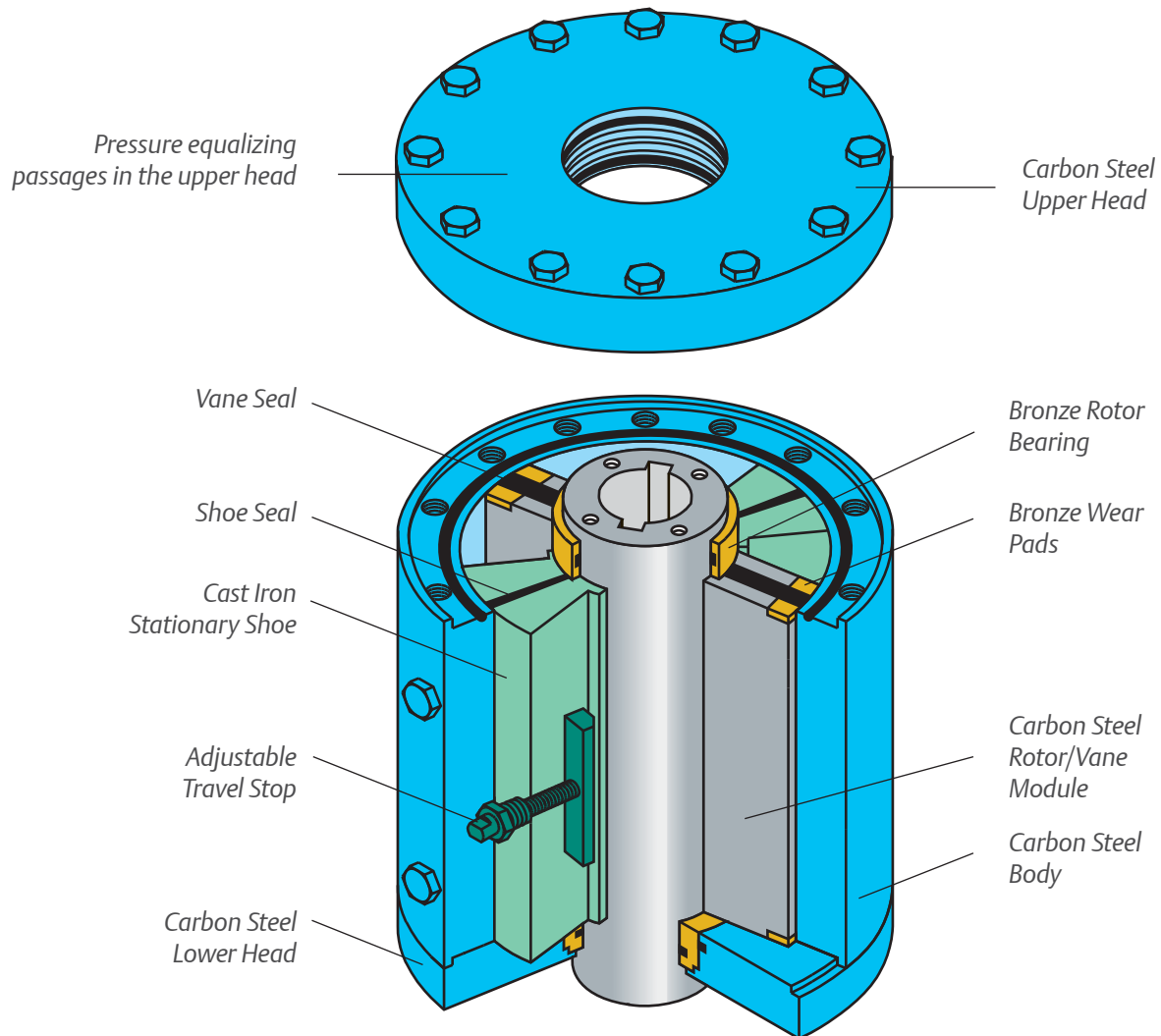

Performance Features

- Life expectancy is 50 years with minimal maintenance
- Proven reliability backed by a 10 year warranty
- The most compact actuator available
- The double vane design will not generate any side loading forces on the valve stem or actuator bearings
- Constant torque output over the full 90° rotation
- Vibration resistant with the actuator body centered directly over the valve stem and weight equally distributed over the valve flange
- Maximum rated pressure and maximum operating pressure are equal
- Valve response is always smooth and always dependable



Operating Sequence

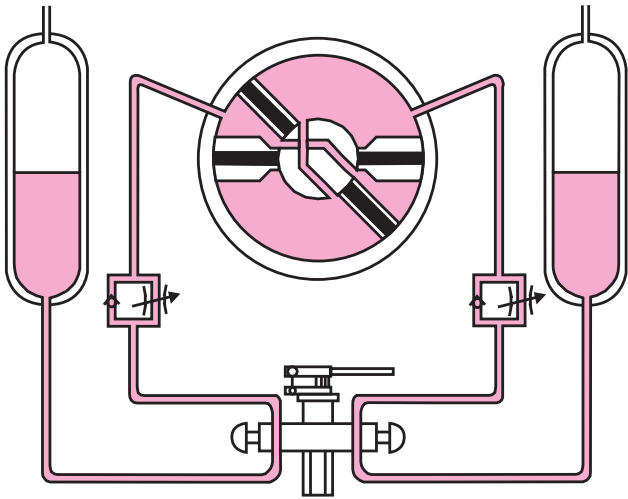

SEQUENCE 1

The actuator may be powered by a hydraulic power unit, stored gas pressure or by natural gas pressure from a pipeline. In this illustration, the actuator is fitted with gas hydraulic tanks and is powered by gas pressure. In the first sequence, the actuator is in the open position. There is no pressure in the actuator or tanks.

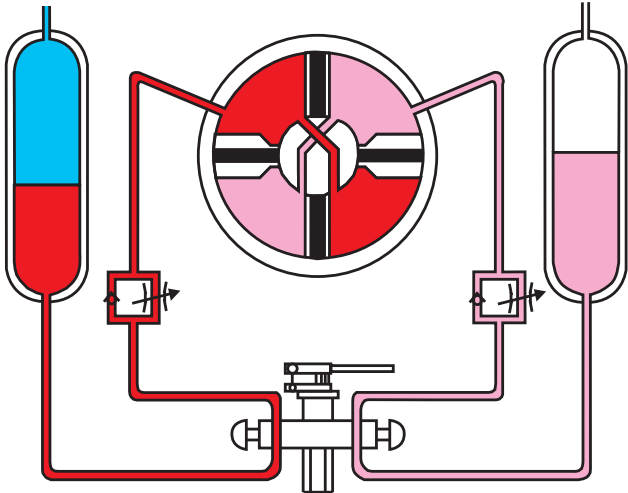

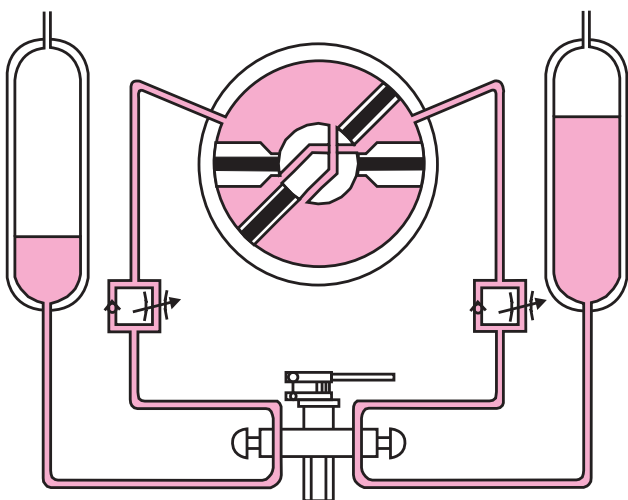

SEQUENCE 2

The actuator control system is used to admit high pressure gas into the closing gas hydraulic tank. The pressurized gas in the tank forces hydraulic fluid into the actuator's closing port. Pressure equalizing passages allow both closing quadrants to be pressurized simultaneously providing balanced torque as the vanes push away from the stationary shoes. The actuator is rotating clockwise.



SEQUENCE 3

When the actuator reaches the fully closed position, the control system will allow all remaining pressure in the tank to vent to atmosphere, thus neutralizing the pressure in the tank and actuator.

-  High Pressure Gas
-  Pressurized Hydraulic Fluid
-  Non-Pressurized Hydraulic Fluid

Shafer designs, builds and tests the complete valve operating system, including the actuator, controls and accessories. When you specify Shafer, you receive a complete system, factory tested, field proven and **guaranteed**.

Shafer RV-Series actuators can be operated locally, remotely or automatically by a variety of sensory and control devices. We have developed more than 4000 individual control systems to meet the many requirements of our customers.

TYPICAL CONTROL SYSTEMS

- Local manual
- Remote two-way electric
- Linebreak Protection sensing rate of pressure drop
- Emergency Shutdown (ESD) or fail-safe
- High/low pressure shutoff

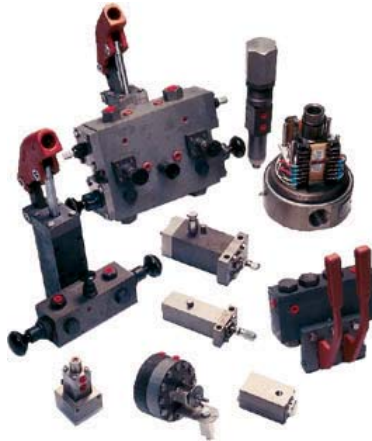

All accessories have undergone thorough testing and field evaluation to insure their performance as part of a larger system

COMMON ACCESSORIES

- Manual hydraulic hand pump
- Control valves –hydraulic and pneumatic
- Sensors for automatic operation
- Power storage vessels
- Power supply units
- Limit switches and position transmitters
- Speed controls
- Regulators
- Filters

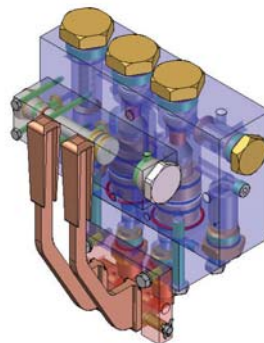

*Proven reliability
backed by a 10 year
warranty*

*More than 4000
control systems
developed.*

*We design, build and
test the complete
valve control system*



Distributed by | Distribuido por :



ANYTHINGTM
≈ FLOWS ≈

INFO@ANYTHINGFLOWS.COM

WWW.ANYTHINGFLOWS.COM

Flow Control , our passion ®

Life Flows on TM



SCAN ME