

Stainless steel quarter-turn actuators **MORIN S**

Stainless steel spring-return and double-acting pneumatic quarter-turn actuators

For remote control of any quarter-turn application: ball, butterfly, rotary plug or damper style valves, etc. To be used in chemical process, food and beverage, iron and steel, off-shore marine, pharmaceutical, power, oil and gas, pulp and paper, and textile industries.



Technical Data

Supply pressure: 40 to 160 psi (3 to 11 barg) (see torque charts)

Supply medium: Air or any gas compatible with materials of construction. Water hydraulic optional

Output torques: Up to 120,000 in-lb (13,560 Nm)

Temperature rating

Standard range: -29°C to 99°C (-20°F to +210°F)

Optional range: -54°C to 149°C (-65°F to +300°F)

Angular rotation: 90° ± 8 degrees

Protection: IP66; IP68 (optional)

Certification: SIL3 rated, ATEX, PED, ISO9000, ABS

Key Features and Benefits

- Innovative stainless steel construction provides superior internal and external corrosion resistance
- Scotch yoke design using precision bearings eliminates dead band in the yoke mechanism, providing the greatest torque output at the beginning and end of stroke
- High strength 17-4PH stainless output shaft transmits torque and gives long service life
- Heat-treated stainless steel thrust pin and rollers transfer piston force to yoke to reduce friction for longer life and more efficient torque transmission
- Bi-directional travel stops provide accurate valve rotation adjustment
- PTFE piston bearings, piston rod bushings and output shaft bushings provide longer life, reduce maintenance and require no lubrication
- Universal design position indicator and pointer allows for either parallel or perpendicular mounting
- Optional proximity switch mounting
- NAMUR drive slot maintains a compact assembly for accessory-driven components with no couplings necessary.
- Available in symmetrical and canted yoke design to suit application
- "Man-safe" spring design. Spring return model design requires no special tools to disarm springs safely and easily, reducing downtime

Scotch-yoke quarter turn actuators **MORIN B & C**

B Series - Ductile iron with stainless steel cylinders
C Series - Ductile iron with carbon steel cylinders
Spring-return and double-acting actuators

For remote control of any quarter-turn application: ball, butterfly, rotary plug or damper style valves, etc. for use in chemical process, food and beverage, iron and steel, pharmaceutical, power, oil and gas, pulp and paper and textile industries.



Technical Data

Supply pressure: 40 to 160 psi (3 to 11 barg) (see torque charts)

Supply medium: Air or any gas compatible with materials of construction. Water hydraulic optional

Quarter-turn output torques: Up to 120,000 in-lb (13,560 Nm)

Temperature rating

Standard range: -29°C to 99°C (-20°F to +210°F)

Optional range: -54°C to 149°C (-65°F to +300°F)

Mounting pattern: ISO 5211

Protection: IP66

Certification: SIL3 capable, ATEX, PED, ISO9000, ABS

Key Features and Benefits

- Cylinders are 316 stainless steel on the B Series and Xylan™ coated steel on the C Series
- High strength alloy steel or 17-4PH stainless output shaft transmits torque without fatigue
- Sintered bronze or PTFE composite output shaft bushings eliminate side loading of valve stem to maximize stem packing performance
- Durable corrosion-resistant chrome-plated steel alloy piston rod for enduring high cycle applications
- Sintered bronze piston rod bushings provide low-friction support and precise alignment to increase efficiency, reduce maintenance and extend actuator life
- Heat-treated stainless steel thrust pin and rollers transfer piston force to yoke to reduce friction for longer life and more efficient torque transmission
- PTFE guide bands ensure low-friction piston guidance, protecting cylinder walls from scoring and extending seal performance with a continuous cylinder wiping action
- Bi-directional travel stops provide accurate valve rotation adjustment
- NAMUR drive slot maintains a compact assembly for accessory-driven components with no couplings necessary.
- “Man-safe” spring design. Tectyl-coated springs need no special tools to be disarmed safely and easily, reducing downtime
- Easily removable housing cover provides easy access for yoke mechanism inspection
- Optional proximity switch mounting is available



High pressure actuators **MORIN HP**

HP Series

- Direct gas / hydraulic actuator with ductile iron housing and carbon steel cylinders
- Spring-return and double-acting actuators

Designed specifically for automating quarter-turn pipeline valves, providing control for any quarter-turn ball, plug or butterfly valve application.



Technical Data

- Supply pressure:** Up to 155 barg /2250 psig (see torque chart)
- Supply medium:** Any pneumatic or hydraulic fluid compatible with materials of construction
- Output torques:** Up to 115,000 in-lb (13,000 Nm)
- Temperature rating**
 - Standard: -29°C to 99°C (-20°F to +210°F)
 - Optional: -54°C to 149°C (-65°F to 300°F)
- Mounting pattern:** ISO 5211
- Protection:** IP66
- Certification:** SIL3 rated, ATEX, PED, ISO9000, ABS

Key Features and Benefits

- High pressure construction eliminates undesirable regulators and relief valves for supply pressures
- Optional hydraulic dampening provides smooth “open-close” operation to prevent detrimental valve slamming
- Ductile iron housing provides long life and durable, cost effective operation
- High strength alloy steel or 17-4PH stainless output shaft transmits torque without fatigue
- Sintered bronze or PTFE composite output shaft bushings eliminate side loading of valve stem to maximize stem packing performance
- Durable corrosion-resistant chrome-plated steel alloy piston rod for enduring high-cycle applications
- Sintered bronze piston rod bushings provide low-friction support and precise alignment to increase efficiency, reduce maintenance and extend actuator life
- Heat-treated stainless steel thrust pin and rollers transfer piston force to yoke to reduce friction, for longer life and more efficient torque transmission
- Bi-directional travel stops provide accurate valve rotation adjustment
- NAMUR drive slot maintains a compact assembly for accessory-driven components with no couplings necessary
- Tectyl-coated springs need no special tools to be disarmed safely and easily, reducing downtime
- Easily removable housing cover provides easy access for yoke mechanism inspection
- “Man-safe” spring design. Spring return model design requires no special tools to disarm springs safely and easily, reducing downtime
- Also available in electro-hydraulic

MATERIALS OF CONSTRUCTION

S-Series

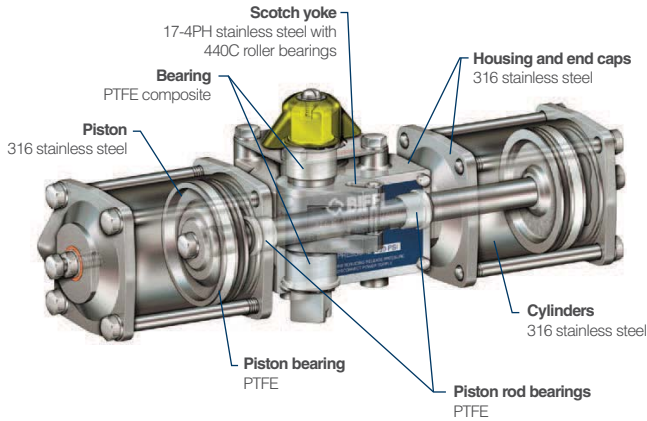

Double Acting - Models 003 To 100

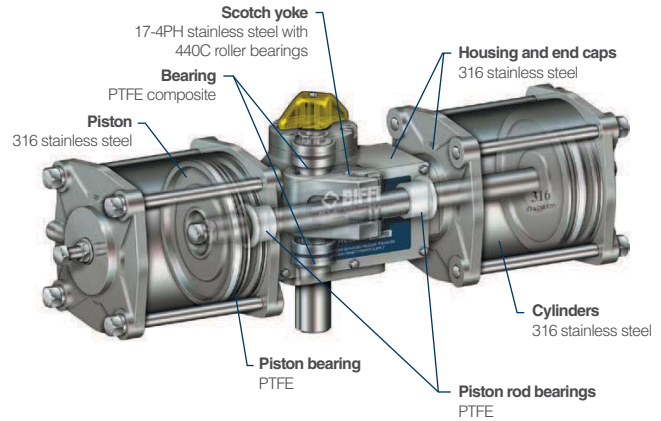

Double Acting - Models 135 To 1150

B & C Series

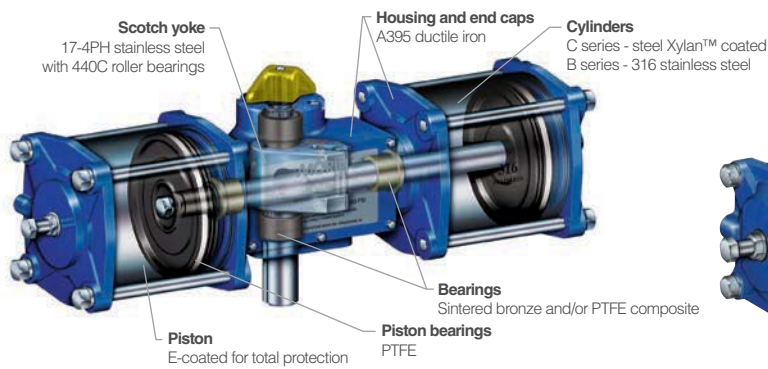

B Or C Series, Models 135 To 1150

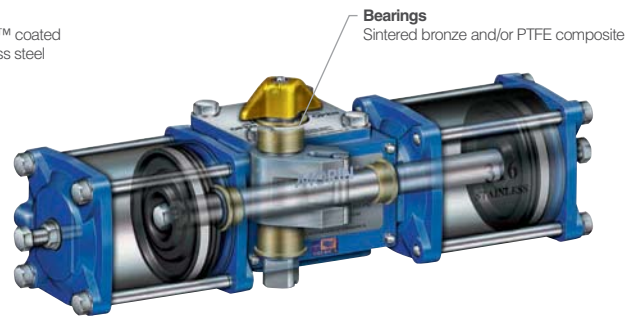

B Series Models 006 To 100

Models 006 to 100 come standard with stainless steel bolting, output shaft, and cylinders

HP-Series

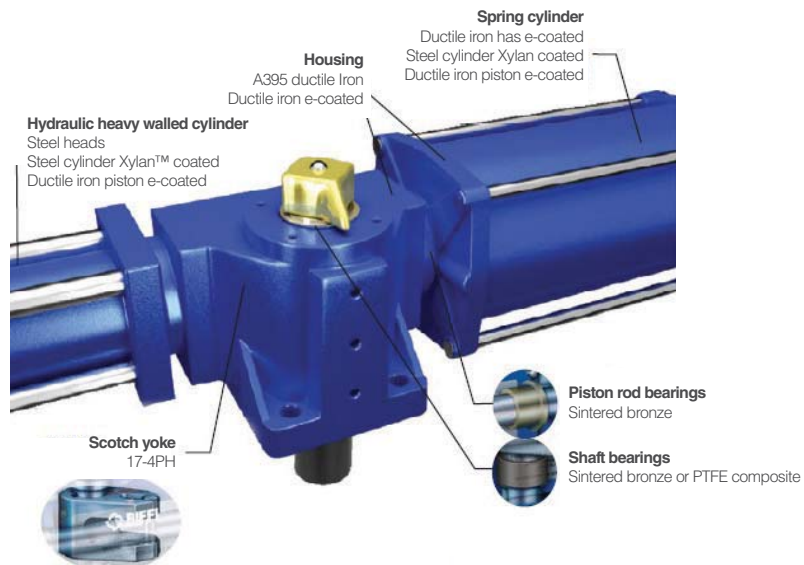

Model HP15 is standard with 17-4PH shaft

Options



Partial Stroke test Device (PSTD)
Provides a method of testing ESD packages without shutdown.



Lockout
Integral lockout allows safe shutdowns for maintenance and isolation of systems.



Jackscrew override (JSO)
Manual operation when power is lost. Simple and effective.



Hydraulic override (MHP)
Manual operation when power is lost. Includes speed controls.



AWWA
Tested per American Waterworks Association C540. Available for pneumatic or water service operation.



Proximity switch preparation
Allows installation of cartridge style proximity switches. Leaves top works open for mounting of other devices.



Direct mounting cast adapters
Many valve top works covered, including some ISO mounting. Assures economic but correct mounting alignment.

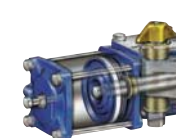

Full stroke adjuster
Provides mechanical control of maximum and/or minimum valve stroke.



Epoxy painting (EX)
Offshore rated, three-part coating system for high level of environmental protection.

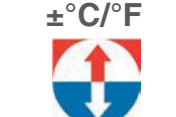

High or low temperature ratings
Standard rating of -29°C to 99°C (-20°F to 210°F) covers most applications. Optional ratings down to -54°C (-65°F) and up to 149°C (300°F).



Distributed by | Distribuido por :



ANYTHINGTM
≈ FLOWS ≈

INFO@ANYTHINGFLOWS.COM

WWW.ANYTHINGFLOWS.COM

Flow Control , our passion ®

Life Flows on TM



SCAN ME