

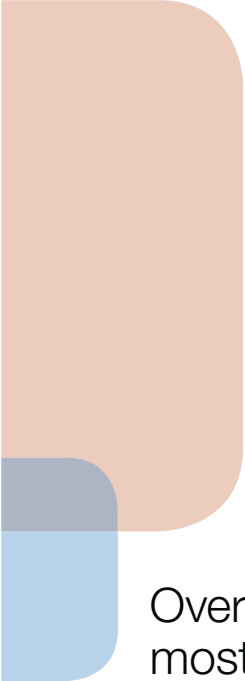

ACTUATION SOLUTIONS

EXPERIENCE
MORE



Overcome your most demanding automation challenges with our smart and reliable valve automation solutions

■ **Maximize your plant's safety with the most advanced technology**

With more than **60 years of experience**, Biffi is a recognized market leader in delivering reliable and safe actuation and control solutions, with a proven expertise in solving the most demanding valve automation needs of oil & gas, power, processing, and water industry operators. Our focus on technology provides increasingly **smart systems** to control and monitor valves, and allows us to offer both **standard and custom made solutions**, enabling Biffi Customers to maximize their plant's productivity, reducing downtime and ensuring highest performance levels in a safe working environment.

■ **Get top quality products, entirely engineered and manufactured in Italy**

In-house and fully integrated **design, manufacturing and testing facilities**, guarantee the highest quality standards of every Biffi product, which is individually torque and performance tested to maximize its **reliability** and **durability**.

EXPERIENCE
MORE



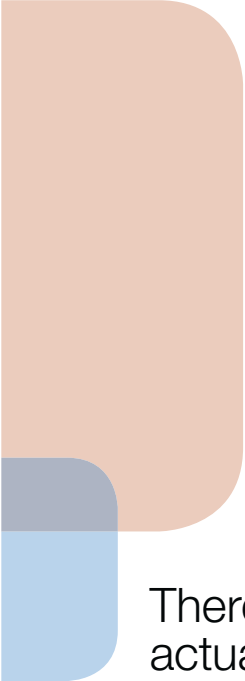

There is one best actuation solution for your plant, and we support you in realizing it

■ Designed around your plant's requirements

Understanding and solving Customer's problems, protecting plant assets, personnel and the environment with smarter, safer and more efficient operation is our top priority.

Our team of actuation experts with a unique **cross-functional expertise in valve automation**, safety applications, process control and digital communications, aims at being a global partner, to effectively support every Customer throughout the whole selection and decision-making process.

■ Rely on us, anytime and anywhere

Biffi's Lifecycle Services Program allows your plant to operate safely, consistently and economically, improving your asset reliability and preserving your investment.

Our dedicated **Lifecycle Services network** covers all geographical areas, ensuring quick and professional support, including site walkdown and asset review, installation, commissioning, maintenance, troubleshooting and repair, STO (Shutdown, Turnaround, Outage) support, upgrade, replacement, retrofit and spare parts management.

Furthermore, the Biffi **School of Actuation** supports Customers to optimize their plant performance through dedicated training sessions for site people.



■ Don't compromise with product quality

In-house design, manufacturing and testing of every actuator component, guarantee the **highest quality standards** of our trusted products.

■ Rely on sophisticated technology content

Fully SIL3 certified solutions (IEC-61508 1-7:2010 SIL 2&3) provide **exceptional performance** in the most **extreme operating conditions**. Smart control and networking devices improve the actuator capabilities with a wide range of bus communication protocols, position feedback, PST capabilities and more.

■ Achieve top quartile performances

Best-in-class valve control and automation solutions minimize plant shutdowns and maintenance costs, and **optimize productivity**.

■ Experience smooth integration and flexibility

The compliance with open standards allows networking and interoperability and reduces integration complexity.



Low pressure actuators

Robust, versatile, high performing actuators with fail safe capability

All low pressure actuators are available in double-acting and spring return versions for any quarter-turn or linear valve.

- Scotch yoke actuators
- Heavy duty rack & pinion actuators
- Linear actuators
- Helical slot (see under compact actuators, page 13)

Scotch yoke actuators

ALGA - ALGAS



ALGA-ALGAS pneumatic scotch yoke actuators are suitable for quarter-turn valves up to the largest sizes, thanks to an efficient design and to high break-out torque. The QA version with damper performs fail stroking in less than 1 second.

- Design pressure: 12 bar g (174 psi)
- Double acting torque: up to 750.000 Nm (6,630,000 Lb in)
- Spring ending torque: up to 235.000 Nm (2,078,000 Lb in)

MORIN S-SERIES



MORIN S scotch yoke actuators have a full stainless steel construction, providing maximum corrosion resistance under the harshest ambient conditions.

- Design pressure: 11 bar g (160 psi)
- Double acting torque: up to 26.900 Nm (238,000 Lb in)
- Spring ending torque: up to 11.760 Nm (104,125 Lb in)

Heavy duty rack & pinion actuators

RPD - RPS



RPD-RPS rack & pinion actuators offer a reliable, easy and cost effective solution, providing maximum torque output with minimum supply pressure. The housing can be ductile iron or carbon steel; all other parts are in carbon steel as a minimum.

- Design pressure: 12 bar g (174 psi)
- Double acting torque: up to 3.700 Nm (32,700 Lb in)
- Spring ending torque: up to 1.100 Nm (9,700 Lb in)

Linear actuators

PLA - PLAS



PLA-PLAS linear actuators are suitable for any linear valve, with thrust and stroke available according to Customer's requirements.

- Design pressure: 12 bar g (174 psi)
- Double acting thrust: up to 1.600.000 N (359,000 Lb)
- Spring ending thrust: up to 555.000 N (124,800 Lb)



High pressure actuators

Proven in-field technology

Biffi has been a major supplier of pipeline/direct gas and gas-over-oil actuators for high pressure applications for over five decades, with many thousands of units providing reliable, effective service worldwide in the most remote locations, from the Siberian steppes to the Arabian deserts.

- Scotch yoke actuators
- Direct gas/Gas over oil actuators
- Heavy duty rack & pinion actuators
- Linear actuators
- Helical slot (see under compact actuators, page 13)

Scotch yoke actuators

■ OLGA - OLGAS



Efficient design and high break-out torque make OLGA and OLGAS hydraulic actuators suitable for most quarter-turn valves and larger heavy-duty applications.

- Design pressure: up to 350 bar g (5,076 psi)
- Double acting torque: up to 1.000.000 Nm (8,850,745 Lb in)
- Spring ending torque: up to 235.000 Nm (2,079,000 Lb in)

Direct gas/Gas over oil actuators

■ GIG/S - GPO



GIG/S and GPO with fully integrated control systems combine high pressure components entirely designed by Biffi, including conventional or electronic line break monitoring systems, where requested.

- Design pressure: 100 bar g (1,500 psi)
- Double acting torque: up to 750.000 Nm (6,630,000 Lb in)
- Spring ending torque: up to 235.000 Nm (2,079,000 Lb in)

Heavy duty rack & pinion actuators

■ RPHD - RPHS



RPHD and RPHS hydraulic actuators are suitable for high pressure applications and on/off or modulating heavy duty service.

- Design pressure: up to 220 bar g (3,190 psi)
- Double acting torque: up to 2.600 Nm (23,000 Lb in)
- Spring ending torque: up to 950 Nm (8,400 Lb in)

Linear actuators

■ HLA - HLAS



HLA and HLAS hydraulic actuators are designed for on/off and modulating control of any linear valve, with thrust according to Customer's requirements.

- Design pressure: up to 350 bar g (5,076 psi)
- Double acting thrust: up to 8.000.000 N (1,798,000 Lb)
- Spring ending torque: up to 350.000 N (78,000 Lb)



Electro-hydraulic solutions

Smart and fast: double-acting and spring-return solutions when electrical power is the only available source

Both basic and smart electro-hydraulic solutions use a self-contained power unit to operate and control the actuators allowing high torque, high speed modulating and/or fail-safe action when only electric power is available and reliability is crucial. The standard version is for on/off ESD/HIPPS applications, while the smart version is designed for modulating ESD applications and provides alert, alarm, diagnostic, and self-calibration features.

- Standard electro-hydraulic actuators
- Custom made electro-hydraulic actuators with accumulator
- Smart electro-hydraulic actuators

Standard electro-hydraulic actuators

EHA/EHB



Quarter turn (linear as option) actuator with simple and reliable design, providing fail-safe spring return operation in the event of a power failure. Smart diagnostics is available with IMVS2 integrated monitoring system.

- Design pressure: 220 to 345 barg (3,190 to 5,000 psi)
- Wide range of Vac or Vdc power supplies
- Spring ending torque: 135 to 5,650 Nm
- Power supply: 120 or 240 V AC 1ph 60 Hz

Custom made electro-hydraulic actuators with accumulator

EHT



Self-contained system, including a high pressure actuator with hydraulic motor pump for quarter-turn and linear applications.

- Design pressure: 220 to 345 barg (3,190 to 5,000 psi)
- Wide range of Vac or Vdc power supplies
- Single and double acting
- Includes hydraulic accumulators, electric motor pumps, switches and controls
- On-off application with high speed fail action (less than 0,3 sec)

Smart electro-hydraulic actuators

S-EHT

S-EHT is a self-contained system allowing high level diagnostics, digital and analog control through all major serial bus protocols, and wireless access via Bluetooth. It includes a high-pressure actuator with hydraulic motor pump system, suitable for quarter-turn and linear applications, equipped with dedicated electronic control unit.

- Design pressure: 220 to 345 barg (3,190 to 5,000 psi)
- Wide range of Vac or Vdc power supplies available
- Single and double acting
- Includes hydraulic accumulators, redundancy or single electric motor pumps, switches and controls.
- Universal solution for all valve applications: on-off, with high speed fail action, position control, heavy duty modulation.
- Wide range of local and bus communication interfaces

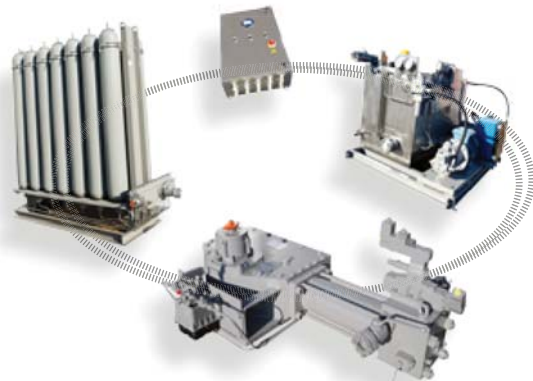



Compact actuators

Reduced footprint, same performances

Bi ffi compact actuators are the ideal solution where space is limited, but top performance is required, like offshore platforms, onshore terminals, tank farms, FPSOs, as well as oil refineries and power plants.

They are available single acting for linear and quarter turn applications, with the spring integrated into the cylinder.

- Compact quarter-turn pneumatic and hydraulic actuators
- Compact linear hydraulic actuators

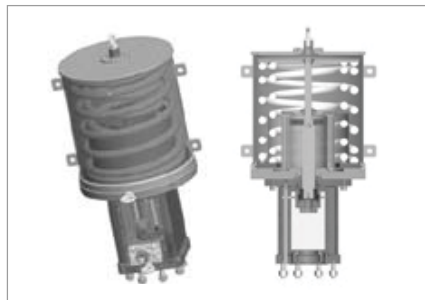
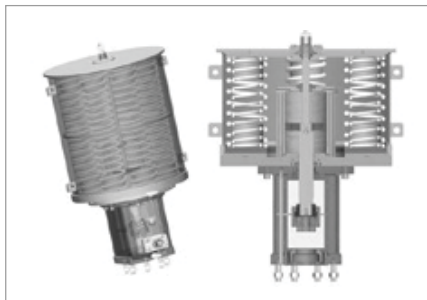

Compact quarter-turn pneumatic and hydraulic actuators

The TPD - TPS quarter turn actuator's footprint is reduced, thanks to a unique helical slot design, which transforms the linear movement of the piston into a quarter turn rotation, generating high breakout torques, and reducing both size and weight.

TPD - TPS

- Design pressure: 12 bar g (174 psi)
- Double acting torque: up to 300.000 Nm (2,665,000 Lb in)
- Spring ending torque: up to 66.000 Nm (584,000 Lb in)



THD - THS

- Design pressure: 350 bar g (5,000 psi)
- Double acting torque: up to 300.000 Nm (2,665,000 Lb in)
- Spring ending torque: up to 66.000 Nm (584,000 Lb in)



Compact linear hydraulic actuators

HLA - C



HLA-C and HLAS-C compact linear actuators are designed for on/off and modulating control of any linear valve, with thrust according to Customer's requirement.

- Design pressure: up to 350 bar g (5,076 psi)
- Double acting thrust: up to 8.000.000 N (1,798,000 Lb)
- Spring ending torque: up to 350.000 N (78,000 Lb)



Quick acting actuators

■ The quickest actuation solution for maximum plant safety

This family of special fail-safe pneumatic and hydraulic actuators enhances the safety of your plant. They feature integral quick exhaust valves (pneumatic) or high flow dump valves (hydraulic) and effective end-of-stroke shock absorbing systems to combine highest speed performance with maximum safety and reliability. Both pneumatic and hydraulic quick-acting actuators can be provided with modulating control circuits and partial stroke test (PST) capability.

- Quick acting pneumatic, hydraulic, electro-hydraulic actuators

Quick acting pneumatic, hydraulic, electro-hydraulic actuators

■ ALGAS - QA



ALGAS QA are quick-acting spring return pneumatic actuators with integral quick exhaust valves and end-of-stroke shock absorbing systems designed by Biffi.

- Design pressure: up to 12 bar g (174 psi)
- Operating time: less than 1 sec.

■ OLGAS - QA



OLGAS QA is the quick-acting spring return hydraulic and electro-hydraulic actuators with high flow rate manifold and cylinder, integral quick exhaust valves, and end-of-stroke damper systems, designed by Biffi.

- Design pressure: up to 250 barg (3600 psi)
- Operating time: less than 0.3 sec.



Valve Operating Systems (VOS)

Fully customizable control systems for highest performance

Biffi's core expertise, collected across many decades enables us to provide valve automation solutions with highly engineered systems for local or remote control of on/off or modulating actuators, via electric or pneumatic signals.

These electromechanical control systems provide dependable "fail-safe" or "fail-steady" functionality in the event of an emergency, like electric or pneumatic supply failure, high temperature, low or high pipeline pressure. Biffi automated solutions are SIL3 capable and completely designed and manufactured in-house.

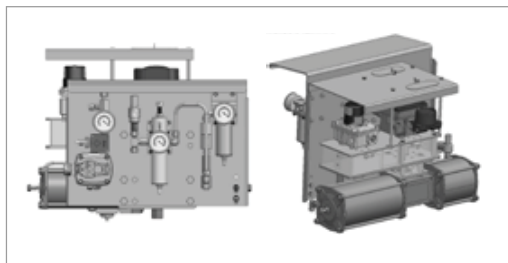



Electric actuators

Smart and fail safe solutions for integrated systems

Biffi offers a wide range of smart electric actuators for quarter and multi-turn applications. Shutdown capability and smart technology, to remotely control and operate valves, guarantee the highest safety in the event of an emergency.

- Multi-turn actuators
- Quarter-turn actuators
- Electric fail-safe actuators



EXPERIENCE
MORE

Multi-turn actuators

■ ICON3000



Smart multi-turn actuator with advanced communication technology, data management and reliable operation.

- Torque: 30 to 1.440 Nm (265 to 12745 Lb in)
- Voltages: 24 V DC to 690 V AC (3 phase)
- Temperature range : -60°C to +85°C (-76°F to +185°F)
- Speed range: 12 to 173 rpm
- A Manager diagnostic software compatibility
- Low power version available 30Nm (265 Lb-in) / 24VDC / 1,3A

Quarter-turn actuators

■ F01



Advanced technology electric quarter turn actuator for small valves.

- Torque: up to 600 Nm (5,310 Lb in)
- Time/90° stroke: from 5 up to 60 sec.
- Temperature range: -20°C to +85°C (-4°F to + 185°F)

■ F02



Light weight smart quarter turn actuator.

- Torque: 63 to 2.000 Nm (557 to 17,701 Lb-in)
- Voltage: from 24 to 240 VDC or VAC 1PH; from 208 to 575 VAC 3PH
- Temperature range: -40°C to +70°C (-40°F to +58 °F)

Electric fail-safe actuators

■ EFS2000



Designed for fail open/close operations in emergency conditions. Compliant with all open bus protocols, with PST capability. SIL 3 rated, suitable for ROSOV (remote operated shut-off valves).

- Spring operation: starting torque up to 18000 Nm (159313 Lb-in), ending torque up to 9000 Nm (79656 Lb-in)
- Voltage: from 24 to 110 VDC; from 110 to 240 V 50/60Hz 1PH; from 208 to 690 V 50/60Hz 3PH
- Temperature range: -45°C to +85°C (-49°F to +185°F)
- Safety integrity level (IEC 61508-1÷7:2010) - SIL3



Control and networking solutions

Keep your plant always under control with the most advanced and reliable technology

Biffi networking solutions are based on intelligent actuators and smart devices for detection and monitoring, enabling diagnostic functions, while valves are online and in service. Biffi master stations allow remote control of the actuators, through the most common bus protocols, guaranteeing maximum plant reliability even in the most severe operating conditions.

- Electronic Control Units
- Integrated Valve Monitoring System
- Electronic line break systems
- Diagnostic communication

Electronic Control Units

■ ECU1000



This component of the integral control panel provides control and diagnostics functions for any Biffi electro-hydraulic actuator like:

- Control on-off and positioning of modulating actuators (heavy duty, low drain-heavy duty, stepping)
- Control of integral HPU with single or dual pump with automatic switch
- PST and interlock function
- Outputs to control on-off Solenoid Operated Valves (SOV's), Servo valves, Proportional Valves, Electrical Motors Hardwired and BUS remotely controlled

Electronic line break systems

■ ELBS20



ELBS20 is a smart device for pipeline pressure monitoring. In case of failure, it sends a command to the actuator to stroke the valve to the defined fail safe position.

- Monitoring of five safety critical parameters: pressure drop rate; pressure decrease and/or increase against reference value, low and/or high limit exceeded
- Modbus RTU (RS485), Bluetooth, RS485 point-to-point, RS232, HART
- Special OLED display to operate down to -40°C (-40°F)

Integrated Valve Monitoring System

■ IMVS2



IMVS2 is an integrated valve monitoring system for high or low-pressure applications with position monitoring and on-line diagnostic capability, testing of all components in the Safety Instrumented function, including multiple solenoid valves.

- Hydraulic or pneumatic PST device
- Asset Management software as a standard
- For Low and High Pressure applications (10 bar pneumatic; up to 400 barg (5,800 psi))
- HART7 and Modbus bus interfaces
- Bluetooth, RS232 and RS485 interface
- On board push button for local setting and commands
- 3xDigital inputs and 6 digital outputs
- Oled graphic display able to operate down to -40°C (-40°F)

Field Gateway

■ DCM2



DCM2 is a highly reliable master station, able to manage up to 300 actuators with up to 18 field loops, providing ultra fast communication speed. Three levels of system redundancy and military encrypted communications guarantee the highest data safety.

- DCS/PLC protocol: MODBUS RTU or TCP/IP
- Field protocol: LONWORKS®, MODBUS®
- 19" 3HE rack for cabinet mounting
- Up to 300 actuators installed/18 loops
- Fast communication to the field

Distributed by | Distribuido por :



ANYTHINGTM
≈ FLOWS ≈

INFO@ANYTHINGFLOWS.COM

WWW.ANYTHINGFLOWS.COM

Flow Control , our passion ®

Life Flows on TM



SCAN ME