



WKM Valves— Triple Offset Valves

High-quality bidirectional valves for critical applications in demanding markets



Contents

Triple offset geometry	3
Major markets	4
Applications	5
Part list: 3 to 24 in	6
Part list: 26 to 60 in	7
Lug pattern dimensions: 3 to 24 in	8
Lug pattern dimensions: 26 to 48 in	11
Short pattern dimensions: 3 to 24 in	13
Short pattern dimensions: 26 to 60 in	16
Long pattern dimensions: 3 to 24 in	20
Long pattern dimensions: 26 to 60 in	22
Gear operator dimensions	26
Pressure and temperature ratings (ASME B16.34)	28
Weights	28
How to order	30

The Difference

Manufacturing

The portfolio of WKM* valves include the triple offset valve (TOV), built with the manufacturing excellence and commitment to quality that comes with all Cameron products. Combined with arduous qualification and testing processes that simulate valve life cycle, the TOV sets a new benchmark for performance.

Support

Our commitment to global support and strategic networks brings the TOV to markets where it's needed, when it's needed—fully designed, tested, qualified, and backed by Cameron. The TOV meets the demanding requirements for bidirectional shutoff, delivery, and quality.

Organization

Our global network of strategic partners helps distribute high-quality valves for critical applications. With millions of valves manufactured by Cameron and delivered around the world, our portfolio also includes ORBIT* rising stem ball valves, and NEWCO* gate, globe, and check valves as part of the Cameron family.

- Strong global distribution network
- Industry leader in valve technology and innovation
- Broadest portfolio of quarter-turn valves in the industry
- In-house engineering and manufacturing
- Commitment to health, safety, and the environment



WKM Valves — Triple Offset Valves

The TOV completes our reliable, performance-proven, quarter-turn butterfly valve portfolio. The true triple offset geometry of this valve allows for bubble-tight sealing to create a valve that delivers fully bidirectional zero-leakage shutoff per API Standard 598.

Backed by our world-class engineering, manufacturing, and sourcing expertise, the TOV provides a trusted solution ideal for crucial applications. Operators around the world rely on our dedication to high-quality standards, competitive manufacturing processes, and world-class support for total valve life cycle support.

Advantages

- True triple offset geometry
- Fully bidirectional zero-leakage shutoff per API 598
- Field-replaceable metal seat
- Life cycle tested as a bubble-tight bidirectional valve
- Standard bearing seals
- Self-centering disc
- Available in a wide range of configurations: lug and short (ISO) and long pattern
- Carbon and stainless steel standard; other materials on request



Triple Offset Geometry

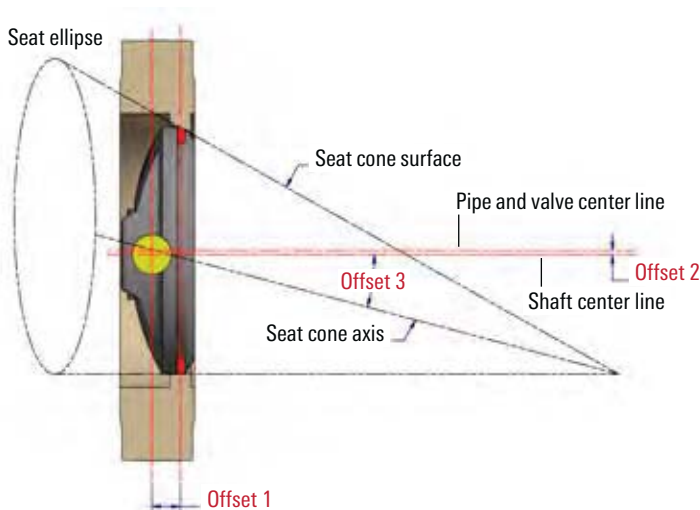

Offset 1 provides full 360° uninterrupted sealing.

Offset 2 provides eccentric rotation of the disc that swings the seal ring completely off the seat upon opening.

Offset 3 moves the centerline of the cone rotation laterally from the centerline of the disc rotation, enabling the cone to seal without rubbing.

Compliance and Specifications

API Standard 609
ASME B16.34
ASME B16.5
API Standard 598
ISO-5752 flange dimension
ASME B16.47 for Series A mating pipe flange dimensions for valve sizes 26 in and larger, Classes 150, 300, and 600
ASME B16.10
MSS-SP-55
ISO 5211
API Standard 607, latest edition for fire testing
Fugitive-emissions testing per API Spec 641 and ISO 15848-1

Major Markets

Power and steam

- District heating
- Bitumen

Petrochemicals (refining and chemicals)

- Coking
- Reformers — cracking
- Tank switching
- Ethylene
- Butadiene
- Isocyanates — plastics

Midstream

- Tank and terminal
- Tank switching
- Long pattern for gate valve replacement
- Storage for all types of hydrocarbons and chemicals
- Liquid transfer

Upstream production

- Process equipment
- Separation — molecular sieve
- Switching
- Floating production platforms
- Manifolds
- Slurry, oil sands, and SAGD methods
- Secondary recovery

Flange Connections



Lug pattern
per API 609

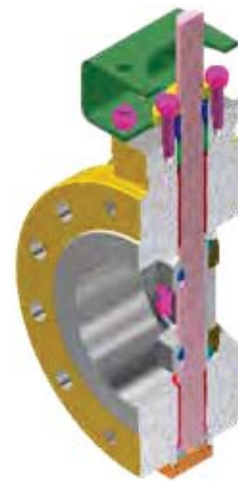

Short pattern
per ISO 5752/API 609

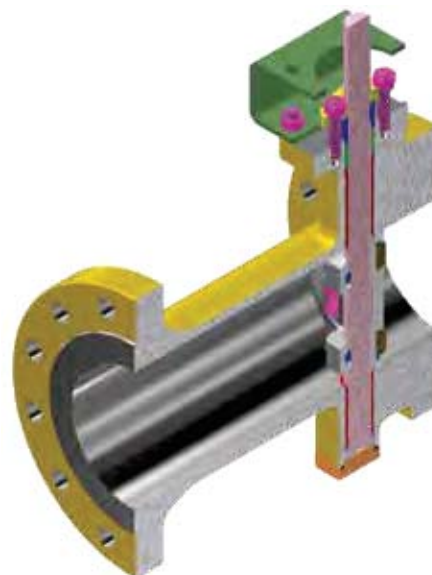

Long pattern
per ASME B16.10
and API 609

Applications

Oil and gas

- Critical isolation
- Steam piping and condensate
- Offshore platforms
- Cooling water systems
- Seawater
- Produced fluids processing systems

Refining and petrochemical processing

- Hydrocarbon processing
- Hydrogen
- Oxygen
- Thermal fluids
- Hot gases
- Sulfur (tail gas)
- Chemical solvents
- Chlorinated solvents
- Flare gas

Liquefied natural gas

- LNG storage
- LNG production

Power and district heating

- Steam isolation
- Hot water control systems
- Geothermal steam

Midstream

- Tank isolation
- Manifold system isolation
- Metering systems
- SCADA systems



Part List: 3 to 24 in

ASME Class 150, 300, and 600—lug, short, and long pattern

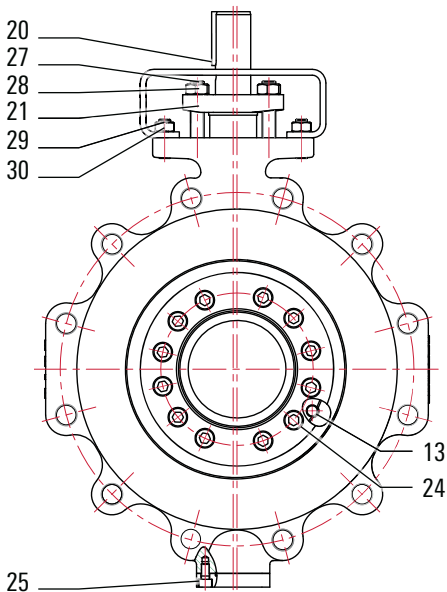
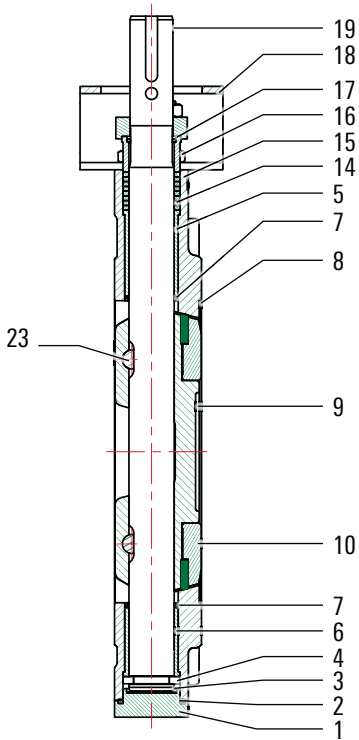

Item	Part	Material	ASTM Specification	Material	ASTM Specification
1	Bottom cap	Carbon steel	A105	Stainless steel	A182 F316
2	Spiral-wound (SW) gasket [†]	SS316 and graphite		SS316 and graphite	
3	Thrust washer	INCONEL® X-750		INCONEL® X-750	
4	Split ring	Stainless steel	A182 F316 with nitriding	Stainless steel	A182 F316 with nitriding
5	Solid bearing top	Stainless steel	A182 FXM-19 with nitriding	Stainless steel	A182 FXM-19 with nitriding
6	Solid bearing bottom	Stainless steel	A182 FXM-19 with nitriding	Stainless steel	A182 FXM-19 with nitriding
7	Bearing seal	Graphite		Graphite	
8	Body	Carbon steel	A216 carbon steel (WCB) and Stellite®	Stainless steel	A351 CF8M and Stellite
9	Disc	Carbon steel	A216 WCB	Stainless steel	A351 CF8M
10	Retainer	Carbon steel	A516 Grade 70	Stainless steel	A240 316
11 [‡]	Seal ring [†]	Duplex and graphite	A182 F51	Duplex and graphite	A182 F51
12 [‡]	Seal ring gasket [†]	Stainless steel and graphite		Stainless steel and graphite	
13	Seal locating pin	17-4PH condition H1150D	A564 630	17-4PH condition H1150D	A564 630
14	Packing washer	Stainless steel	A182 F316	Stainless steel	A182 F316
15	Packing [†]	Graphite		Graphite	
16	Packing bushing	Stainless steel	A182 F316	Stainless steel	A182 F316
17	Blowout ring	17-4PH condition H1150D	A564 630	17-4PH condition H1150D	A564 630
18	Mounting bracket	Carbon steel	A1020	Carbon steel	A1020
19	Shaft	17-4PH condition H1150D	A564 630	17-4PH condition H1150D	A564 630
20	Key	Steel	AISI 1045	Steel	AISI 1045
21	Packing retainer	Carbon steel	A216 WCB	Stainless steel	A351 CF8M
22 [‡]	Center key	Stainless steel	A182 F316	Stainless steel	A182 F316
23	Wedge pin	17-4PH condition H1150D	A564 630	17-4PH condition H1150D	A564 630
24	Socket head cap screw (SHCS)	Carbon steel	A193 B7M	Stainless steel	A453 660D
25	SHCS	Carbon steel	A193 B7M	Stainless steel	A453 660D
26 [‡]	SHCS	Carbon steel	A193 B7M	Stainless steel	A453 660D
27	Stud	Carbon steel	A193 B7M	Stainless steel	A453 660D
28	Hex nut	Carbon steel	A194 2HM	Stainless steel	A453 660D
29	Stud	Carbon steel	A193 B7M	Stainless steel	A453 660D
30	Hex nut	Carbon steel	A194 2HM	Stainless steel	A453 660D
31 [‡]	Nameplate	Stainless steel		Stainless steel	
32 [‡]	Dowel pin	Carbon steel	A105	Stainless steel	A182 F316

[†] Recommended spare parts

[‡] Part not shown

Notes

Basic design—application requirements of API 609B and ASME B16.34

Pressure test—API 598

End flanged—ASME B16.5

Face-to-face dimensions and tolerances—API 609B

Fire test—API 607

Actuation mounting—ISO 5211

Materials meet the requirements of NACE MR0103 and MR0175

Part List: 26 to 60 in

ASME Class 150, 300, and 600—lug, short, and long pattern

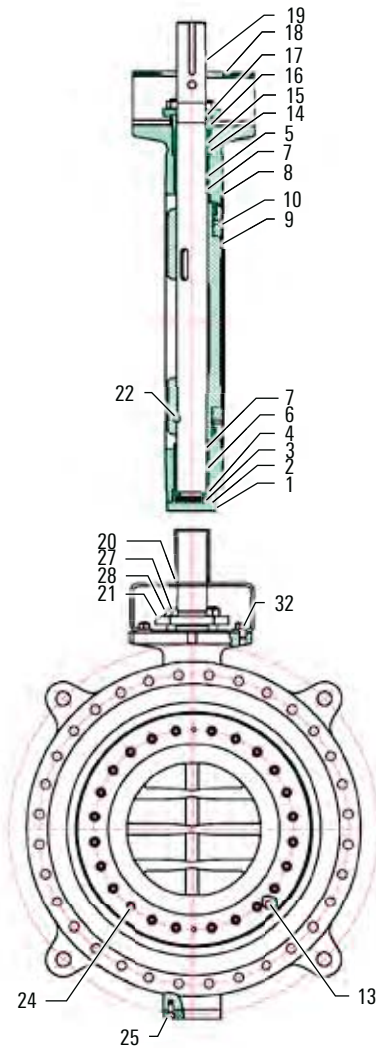

Item	Part	Material	ASTM Specification	Material	ASTM Specification
1	Bottom cap	Carbon steel	A105	Stainless steel	A182 F316
2	SW gasket ¹	SS316 and graphite		SS316 and graphite	
3	Thrust washer	Inconel [®] X-750		INCONEL [®] X-750	
4	Split ring	Stainless steel	A182 F316 with nitriding	Stainless steel	A182 F316 with nitriding
5	Solid bearing top	Stainless steel	A182 FXM-19 with nitriding	Stainless steel	A182 FXM-19 with nitriding
6	Solid bearing bottom	Stainless steel	A182 FXM-19 with nitriding	Stainless steel	A182 FXM-19 with nitriding
7	Bearing seal	Graphite rope		Graphite rope	
8	Body	Carbon steel	A216 WCB + Stellite [®]	Stainless steel	A351 CF8M + Stellite [®]
9	Disc	Carbon steel	A216 WCB	Stainless steel	A351 CF8M
10	Retainer	Carbon steel	A516 Grade 70	Stainless steel	A240 316
11 ¹	Seal ring ¹	Duplex and graphite	A182 F51	Duplex and graphite	A182 F51
12 ²	Seal ring gasket ¹	SS316 and graphite		SS316 and graphite	
13	Seal locating pin	17-4PH condition H1150D	A564 630	17-4PH condition H1150D	A564 630
14	Packing washer	Stainless steel	A182 F316	Stainless steel	A182 F316
15	Packing ³	Graphite		Graphite	
16	Packing bushing	Stainless steel	A182 F316	Stainless steel	A182 F316
17	Blowout ring	17-4PH condition H1150D	A564 630	17-4PH condition H1150D	A564 630
18	Mounting bracket	Carbon steel	A1020	Carbon steel	A1020
19	Shaft	17-4PH condition H1150D	A564 630	17-4PH condition H1150D	A564 630
20	Key	Steel	AISI 1045	Steel	AISI 1045
21	Packing retainer	Carbon Steel	A216 WCB	Stainless Steel	A351 CF8M
22 ²	Cylindrical taper pin	17-4PH condition H1150D	A564 630	17-4PH condition H1150D	A564 630
23 ³	Disc key	17-4PH condition H1150D	A564 630	17-4PH condition H1150D	A564 630
24	SHCS	Carbon steel	A193 B7M	Stainless steel	A453 660D
25	SHCS	Carbon steel	A193 B7M	Stainless steel	A453 660D
26 ⁴	Hex slotted nut	Carbon steel	A194 2HM	Stainless steel	A453 660D
27	Stud	Carbon steel	A193 B7M	Stainless steel	A453 660D
28	Hex nut	Carbon steel	A194 2HM	Stainless steel	A453 660D
29	Stud	Carbon steel	A193 B7M	Stainless steel	A453 660D
30	Hex nut	Carbon steel	A194 2HM	Stainless steel	A453 660D
31 ⁵	Nameplate	Stainless steel		Stainless steel	
32 ⁶	Dowel pin	Carbon steel	A105	Stainless steel	A182 F316

¹ Recommended spare parts

² Part not shown

1. Basic design – Application requirements of API 609B and ASME B16.34

2. Pressure test – API 598

3. End flanges – ASME B16.47 Series A

4. Face-to-face dimensions and tolerances – API 609B, ISO 5752, ASME B16.10

5. Fire test – API 607

6. Materials meet the requirements of NACE MR-01-03 and MR-01-75

Lug Pattern Dimensions: 3 to 24 in per API 609

ASME Class 150, 300, and 600

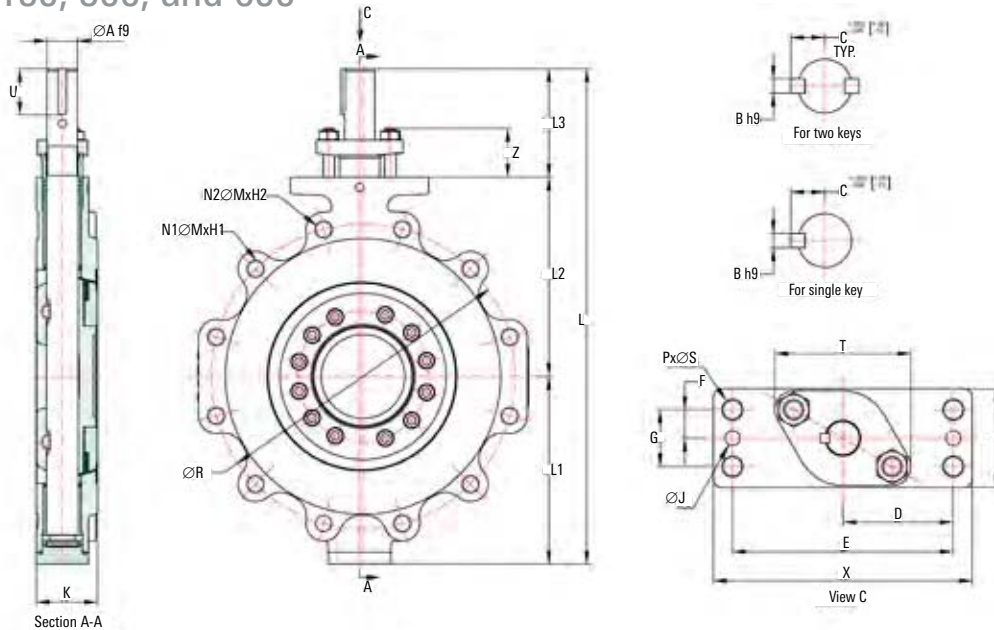

Lug Pattern Dimensions: 3 to 24 in per API 609, ASME Class 150, 300, and 600

Size, in [mm]	Class	ØA f9	B h9	C +0.000/-0.006 [+0.00/-0.15]	NO. OF KEYS	D	E	F	G	K
3 [80]	150	0.83 [21.0]	0.24 [6.0]	0.51 [13.0]	1	1.85 [47.0]	3.70 [94.0]	0.49 [12.5]	0.98 [25.0]	1.88 [48.0]
	300	0.83 [21.0]	0.24 [6.0]	0.51 [13.0]	1	1.85 [47.0]	3.70 [94.0]	0.49 [12.5]	0.98 [25.0]	1.88 [48.0]
4 [100]	150	0.83 [21.0]	0.24 [6.0]	0.51 [13.0]	1	1.85 [47.0]	3.70 [94.0]	0.49 [12.5]	0.98 [25.0]	2.12 [54.0]
	300	0.83 [21.0]	0.24 [6.0]	0.51 [13.0]	1	1.85 [47.0]	3.70 [94.0]	0.49 [12.5]	0.98 [25.0]	2.12 [54.0]
6 [150]	150	1.02 [26.0]	0.31 [8.0]	0.63 [16.0]	1	2.76 [70.0]	5.51 [140.0]	1.02 [26.0]	0.51 [13.0]	2.50 [64.0]
	300	0.98 [25.0]	0.31 [8.0]	0.61 [15.5]	1	2.17 [55.0]	4.33 [110.0]	0.47 [12.0]	0.94 [24.0]	2.25 [57.0]
8 [200]	150	1.18 [30.0]	0.31 [8.0]	0.75 [19.0]	1	2.76 [70.0]	5.51 [140.0]	0.51 [13.0]	1.02 [26.0]	2.31 [59.0]
	300	1.42 [36.0]	0.47 [12.0]	0.91 [23.0]	1	2.95 [75.0]	5.91 [150.0]	1.34 [34.0]	0.67 [17.0]	3.06 [78.0]
10 [250]	150	1.26 [32.0]	0.31 [8.0]	0.75 [19.0]	1	2.76 [70.0]	5.51 [140.0]	0.51 [13.0]	1.02 [26.0]	2.50 [64.0]
	300	1.50 [38.0]	0.39 [10.0]	0.91 [23.0]	2	2.76 [70.0]	5.51 [140.0]	0.67 [17.0]	1.34 [34.0]	2.88 [73.0]
12 [300]	150	1.81 [46.0]	0.55 [14.0]	1.10 [28.0]	2	3.44 [87.5]	6.89 [175.0]	1.77 [45.0]	0.89 [22.5]	4.00 [102.0]
	300	1.42 [36.0]	0.39 [10.0]	0.87 [22.0]	1	2.76 [70.0]	5.51 [140.0]	0.67 [17.0]	1.34 [34.0]	2.81 [71.0]
14 [350]	150	1.57 [40.0]	0.47 [12.0]	0.96 [24.5]	2	3.25 [82.5]	6.50 [165.0]	0.79 [20.0]	1.57 [40.0]	3.25 [83.0]
	300	2.17 [55.0]	0.63 [16.0]	1.32 [33.5]	2	4.43 [112.5]	8.86 [225.0]	2.13 [54.0]	1.06 [27.0]	4.62 [117.0]
16 [400]	150	1.65 [42.0]	0.47 [12.0]	1.00 [25.5]	1	3.25 [82.5]	6.50 [165.0]	0.79 [20.0]	1.57 [40.0]	3.19 [81.0]
	300	1.81 [46.0]	0.55 [14.0]	1.10 [28.0]	2	3.44 [87.5]	6.89 [175.0]	0.89 [22.5]	1.77 [45.0]	3.62 [92.0]
18 [450]	150	2.56 [65.0]	0.71 [18.0]	1.56 [39.5]	2	5.91 [150.0]	11.81 [300.0]	3.15 [80.0]	1.57 [40.0]	5.52 [140.0]
	300	1.77 [45.0]	0.55 [14.0]	1.10 [28.0]	2	3.44 [87.5]	6.89 [175.0]	0.89 [22.5]	1.77 [45.0]	3.62 [92.0]
20 [500]	150	2.17 [55.0]	0.63 [16.0]	1.32 [33.5]	2	4.43 [112.5]	8.86 [225.0]	1.06 [27.0]	2.13 [54.0]	4.62 [117.0]
	300	2.95 [75.0]	0.79 [20.0]	1.79 [45.5]	2	5.91 [150.0]	11.81 [300.0]	3.15 [80.0]	1.57 [40.0]	6.12 [155.0]
24 [600]	150	1.97 [50.0]	0.63 [16.0]	1.22 [31.0]	2	3.44 [87.5]	6.89 [175.0]	0.89 [22.5]	1.77 [45.0]	4.00 [102.0]
	300	2.56 [65.0]	0.71 [18.0]	1.56 [39.5]	2	5.91 [150.0]	11.81 [300.0]	1.57 [40.0]	3.15 [80.0]	5.25 [133.0]
30 [700]	150	3.35 [85.0]	0.87 [22.0]	2.03 [51.5]	2	6.99 [177.5]	13.98 [355.0]	3.54 [90.0]	1.77 [45.0]	7.00 [178.0]
	300	2.28 [58.0]	0.71 [18.0]	1.42 [36.0]	2	4.43 [112.5]	8.86 [225.0]	1.06 [27.0]	2.13 [54.0]	4.50 [114.0]
36 [900]	150	2.76 [70.0]	0.79 [20.0]	1.73 [44.0]	2	5.91 [150.0]	11.81 [300.0]	1.57 [40.0]	3.15 [80.0]	5.88 [149.0]
	300	3.74 [95.0]	0.87 [22.0]	2.22 [56.5]	2	6.99 [177.5]	13.98 [355.0]	3.54 [90.0]	1.77 [45.0]	7.88 [200.0]
42 [1050]	150	2.68 [68.0]	0.71 [18.0]	1.61 [41.0]	2	4.43 [112.5]	8.86 [225.0]	1.06 [27.0]	2.13 [54.0]	5.00 [127.0]
	300	3.07 [78.0]	0.87 [22.0]	1.89 [48.0]	2	6.99 [177.5]	13.98 [355.0]	1.77 [45.0]	3.54 [90.0]	6.25 [159.0]
48 [1200]	150	4.13 [105.0]	0.87 [22.0]	2.42 [61.5]	2	7.99 [203.0]	15.98 [406.0]	4.53 [115.0]	2.26 [57.5]	8.50 [216.0]
	300	3.07 [78.0]	0.87 [22.0]	1.89 [48.0]	2	5.91 [150.0]	11.81 [300.0]	1.57 [40.0]	3.15 [80.0]	6.06 [154.0]
54 [1350]	150	3.62 [92.0]	0.87 [22.0]	2.17 [55.0]	2	6.99 [177.5]	13.98 [355.0]	1.77 [45.0]	3.54 [90.0]	7.12 [181.0]
	300	5.12 [130.0]	1.10 [28.0]	3.19 [81.0]	2	7.99 [203.0]	15.98 [406.0]	4.53 [115.0]	2.26 [57.5]	9.13 [232.0]

All the dimensions are in Inch [Metric]

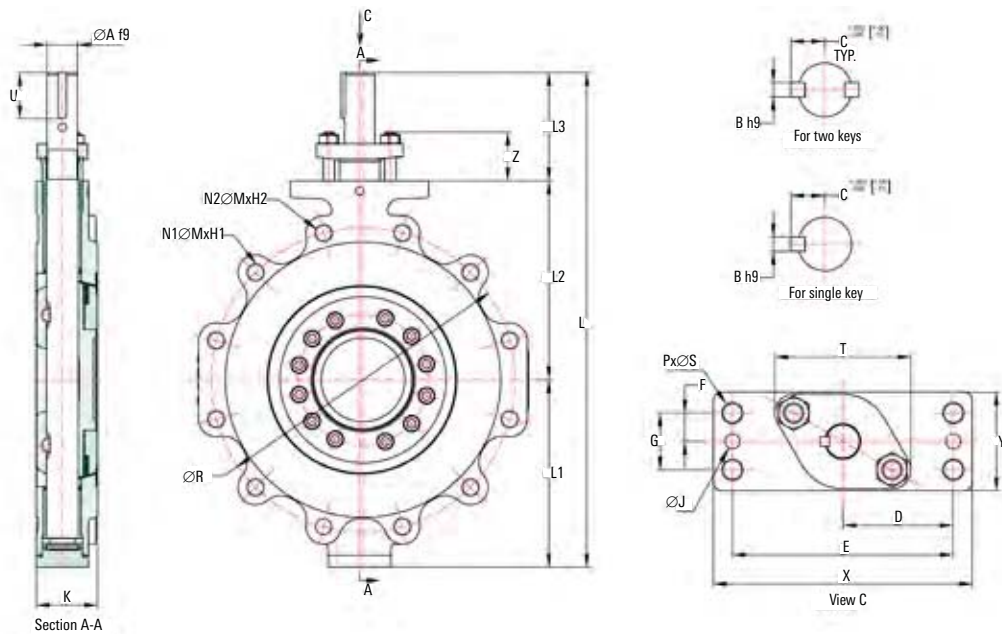

Lug Pattern Dimensions: 3 to 24 in per API 609, ASME Class 150, 300, and 600

Size, in [mm]	Class	L	L1	L2	L3	ØR	P x ØS	ØM	N1 (No's)	N2 (No's)
3 [80]	150	12.68 [322.0]	4.27 [108.5]	3.94 [100.0]	4.47 [113.5]	6.00 [152.4]	4X M8 X 1.25	.625-11 UNC	4	—
	300	13.82 [351.0]	4.67 [118.5]	4.72 [120.0]	4.43 [112.5]	6.62 [168.3]	4X M8 X 1.25	.750-10 UNC	8	—
4 [100]	150	14.65 [372.0]	5.02 [127.5]	5.16 [131.0]	4.47 [113.5]	7.50 [190.5]	4X M8 X 1.25	.625-11 UNC	8	—
	300	15.63 [397.0]	5.57 [141.5]	5.51 [140.0]	4.55 [115.5]	7.88 [200.0]	4X M8 X 1.25	.750-10 UNC	8	—
	600	20.00 [508.0]	7.56 [192.0]	7.52 [191.0]	4.92 [125.0]	8.50 [215.9]	4XM12X1.75	.875-9 UNC	8	—
6 [150]	150	17.09 [434.0]	5.87 [149.0]	6.30 [160.0]	4.92 [125.0]	9.50 [241.3]	4X M10 X 1.50	.750-10 UNC	8	—
	300	20.12 [511.0]	7.09 [180.0]	8.07 [205.0]	4.96 [126.0]	10.62 [270.0]	4X M12 X 1.75	.750-10 UNC	12	—
	600	25.59 [650.0]	9.53 [242.0]	10.04 [255.0]	6.02 [153.0]	11.50 [292.1]	4XM14X2	1.00-8 UNC	10	2
8 [200]	150	19.76 [502.0]	7.09 [180.0]	7.76 [197.0]	4.92 [125.0]	11.75 [298.5]	4X M12 X 1.75	.750-10 UNC	8	—
	300	21.79 [553.5]	8.21 [208.5]	8.66 [220.0]	4.92 [125.0]	13.00 [330.0]	4X M14 X 2.00	.875-9 UNC	12	—
	600	27.60 [701.0]	10.35 [263.0]	10.71 [272.0]	6.54 [166.0]	13.75 [349.2]	4XM18X2.5	1.125-8 UN	10	2
10 [250]	150	23.19 [589.0]	8.78 [223.0]	9.33 [237.0]	5.08 [129.0]	14.25 [362.0]	4X M12 X 1.75	.875-9 UNC	12	—
	300	26.14 [664.0]	9.69 [246.0]	10.24 [260.0]	6.22 [158.0]	15.25 [387.4]	4X M16 X 2.00	1.000-8 UNC	12	4
	600	32.32 [821.0]	11.81 [300.0]	12.20 [310.0]	8.31 [211.0]	17.00 [431.8]	4XM20X2.5	1.250-8 UN	12	4
12 [300]	150	27.01 [686.0]	9.92 [252.0]	10.79 [274.0]	6.30 [160.0]	17.00 [431.8]	4X M16 X 2.00	.875-9 UNC	12	—
	300	30.31 [770.0]	11.10 [282.0]	11.81 [300.0]	7.40 [188.0]	17.75 [450.8]	4X M18 X 2.50	1.125-8 UN	14	2
	600	34.65 [880.0]	13.27 [337.0]	13.39 [340.0]	7.99 [203.0]	19.25 [489.0]	4XM24X3.0	1.250-8 UN	16	4
14 [350]	150	32.44 [824.0]	11.26 [286.0]	13.00 [330.0]	8.19 [208.0]	18.75 [476.3]	4X M16 X 2.00	1.000-8 UNC	12	—
	300	35.91 [912.0]	12.60 [320.0]	13.78 [350.0]	9.53 [242.0]	20.25 [514.4]	4X M20 X 2.50	1.125-8 UN	16	4
	600	39.84 [1012.0]	14.25 [362.0]	14.88 [378.0]	10.71 [272.0]	20.75 [527.0]	4XM24X3.0	1.375-8 UN	16	4
16 [400]	150	35.28 [896.0]	12.52 [318.0]	14.37 [365.0]	8.39 [213.0]	21.25 [540.0]	4X M18 X 2.50	1.000-8 UNC	16	—
	300	40.47 [1028.0]	13.94 [354.0]	15.35 [390.0]	11.18 [284.0]	22.50 [571.5]	4X M24 X 3.00	1.250-8 UN	16	4
	600	45.59 [1158.0]	15.94 [405.0]	16.54 [420.0]	13.11 [333.0]	23.75 [603.2]	4XM30X3.5	1.50-8 UN	16	4
18 [450]	150	38.47 [977.0]	13.78 [350.0]	15.55 [395.0]	9.13 [232.0]	22.75 [577.9]	4X M20 X 2.50	1.125-8 UN	14	2
	300	43.94 [1116.0]	15.16 [385.0]	17.13 [435.0]	11.65 [296.0]	24.75 [628.6]	4X M24 X 3.00	1.250-8 UN	20	4
	600	50.79 [1290.0]	17.99 [457.0]	18.50 [470.0]	14.29 [363.0]	25.75 [654.0]	4XM30X3.5	1.625-8 UN	16	4
20 [500]	150	41.65 [1058.0]	15.12 [384.0]	16.93 [430.0]	9.61 [244.0]	25.00 [635.0]	4X M20 X 2.50	1.125-8 UN	16	4
	300	48.74 [1238.0]	17.05 [433.0]	18.70 [475.0]	13.00 [330.0]	27.00 [685.8]	4X M30 X 3.50	1.250-8 UN	20	4
	600	54.49 [1384.0]	19.17 [487.0]	20.47 [520.0]	14.84 [377.0]	28.50 [723.9]	4XM36X4.0	1.625-8 UN	20	4
24 [600]	150	48.41 [1229.5]	17.50 [444.5]	19.29 [490.0]	11.61 [295.0]	29.50 [749.3]	4X M24 X 3.00	1.250-8 UN	16	4
	300	55.71 [1415.0]	19.37 [492.0]	21.46 [545.0]	14.88 [378.0]	32.00 [812.8]	4X M30 X 3.50	1.500-8 UN	20	4
	600	59.21 [1504.0]	21.14 [537.0]	22.24 [565.0]	15.83 [402.0]	33.00 [838.2]	4XM36X4.0	1.875-8 UN	20	4

All the dimensions are in Inch [Metric]

Lug Pattern Dimensions: 3 to 24 in per API 609

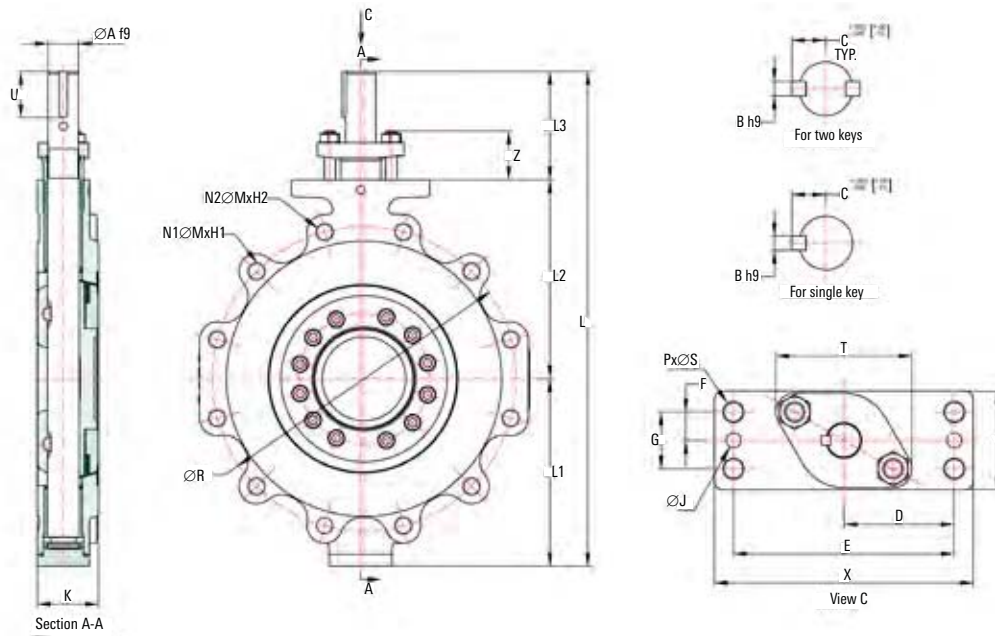

Lug Pattern Dimensions: 3 to 24 in per API 609, ASME Class 150, 300, and 600

Size, in [mm]	Class	H1	H2	ØJ	T	U	X	Y	Z
3 [80]	150	0.79 [20.0]	–	–	2.54 [65.0]	1.77 [45.0]	4.33 [110.0]	1.57 [40.0]	1.70 [43.0]
	300	0.79 [20.0]	–	–	2.54 [65.0]	1.77 [45.0]	4.33 [110.0]	1.81 [46.0]	1.70 [43.0]
4 [100]	150	0.94 [24.0]	–	–	2.54 [65.0]	1.77 [45.0]	4.33 [110.0]	1.65 [42.0]	1.70 [43.0]
	300	0.94 [24.0]	–	–	2.54 [65.0]	1.77 [45.0]	4.33 [110.0]	1.89 [48.0]	1.70 [43.0]
	600	1.02 [26.0]	–	–	3.47 [88.1]	2.17 [55.0]	6.50 [165.0]	2.28 [58.0]	2.09 [53.0]
6 [150]	150	0.94 [24.0]	–	–	2.74 [70.0]	2.17 [55.0]	5.71 [145.0]	1.89 [48.0]	1.97 [50.0]
	300	1.02 [26.0]	–	–	3.47 [88.0]	2.17 [55.0]	6.50 [165.0]	2.13 [54.0]	2.17 [55.0]
	600	1.30 [33.0]	0.67 [17.1]	–	4.33 [109.9]	2.17 [55.0]	7.28 [185.0]	2.91 [74.0]	2.36 [60.0]
8 [200]	150	1.10 [28.0]	–	–	3.55 [90.0]	2.17 [55.0]	6.50 [165.0]	2.13 [54.0]	2.28 [58.0]
	300	0.98 [25.0]	–	–	3.86 [98.0]	2.17 [55.0]	6.50 [165.0]	2.56 [65.0]	2.36 [60.0]
	600	1.77 [45.0]	0.79 [20.0]	0.47 [12.0]	5.04 [128.0]	2.95 [75.0]	8.27 [210.0]	3.54 [90.0]	2.64 [67.0]
10 [250]	150	1.26 [32.0]	–	–	4.07 [104.0]	2.17 [55.0]	6.50 [165.0]	2.44 [62.0]	2.36 [60.0]
	300	1.18 [30.0]	0.68 [17.3]	0.47 [12.0]	4.75 [122.0]	2.76 [70.0]	7.68 [195.0]	2.76 [70.0]	2.56 [65.0]
	600	1.89 [48.0]	0.84 [21.3]	0.47 [12.0]	6.30 [160.0]	3.35 [85.0]	10.63 [270.0]	4.13 [105.0]	3.03 [77.0]
12 [300]	150	1.26 [32.0]	–	–	4.08 [104.0]	2.76 [70.0]	7.68 [195.0]	2.80 [71.0]	2.64 [67.0]
	300	1.38 [35.0]	0.79 [20.0]	0.47 [12.0]	4.25 [108.0]	3.74 [95.0]	8.07 [205.0]	3.07 [78.0]	2.76 [70.0]
	600	1.97 [50.0]	0.84 [21.3]	0.63 [16.0]	6.10 [155.0]	3.94 [100.0]	13.78 [350.0]	5.59 [142.0]	2.95 [75.0]
14 [350]	150	1.50 [38.0]	–	0.47 [12.0]	4.92 [125.0]	3.74 [95.0]	8.07 [205.0]	3.19 [81.0]	3.07 [78.0]
	300	1.65 [42.0]	0.79 [20.0]	0.47 [12.0]	5.71 [144.0]	5.51 [140.0]	10.63 [270.0]	3.94 [100.0]	3.07 [78.0]
	600	2.05 [52.0]	0.94 [24.0]	0.63 [16.0]	7.09 [180.0]	5.12 [130.0]	13.78 [350.0]	5.43 [138.0]	3.27 [83.0]
16 [400]	150	1.38 [35.0]	–	0.47 [12.0]	5.00 [127.0]	3.94 [100.0]	8.07 [205.0]	3.62 [92.0]	3.15 [80.0]
	300	1.89 [48.0]	0.87 [22.0]	0.63 [16.0]	5.63 [143.0]	5.71 [145.0]	13.78 [350.0]	5.12 [130.0]	3.35 [85.0]
	600	2.24 [57.0]	1.02 [26.0]	0.87 [22.0]	8.27 [210.0]	5.91 [150.0]	16.38 [416.0]	6.38 [162.0]	3.70 [94.0]
18 [450]	150	1.73 [44.0]	0.79 [20.0]	0.47 [12.0]	5.31 [136.0]	4.72 [120.0]	10.63 [270.0]	3.70 [94.0]	3.27 [83.0]
	300	1.89 [48.0]	0.87 [22.0]	0.63 [16.0]	5.91 [150.0]	6.30 [160.0]	13.78 [350.0]	5.12 [130.0]	3.39 [86.0]
	600	2.56 [65.0]	1.10 [28.0]	0.87 [22.0]	9.84 [250.0]	7.28 [185.0]	16.34 [415.0]	7.24 [184.0]	3.94 [100.0]
20 [500]	150	1.77 [45.0]	0.71 [18.0]	0.47 [12.0]	6.97 [177.0]	4.72 [120.0]	10.63 [270.0]	4.21 [107.0]	3.50 [89.0]
	300	1.89 [48.0]	0.87 [22.0]	0.87 [22.0]	7.48 [190.0]	6.50 [165.0]	16.73 [425.0]	5.51 [140.0]	3.46 [88.0]
	600	2.56 [65.0]	1.18 [30.0]	0.87 [22.0]	10.04 [255.0]	7.28 [185.0]	19.69 [500.0]	7.87 [200.0]	4.13 [105.0]
24 [600]	150	1.77 [45.0]	0.87 [22.0]	0.63 [16.0]	7.48 [190.0]	6.50 [165.0]	13.78 [350.0]	5.04 [128.0]	3.35 [85.0]
	300	2.24 [57.0]	1.02 [26.0]	0.87 [22.0]	7.48 [190.0]	8.07 [205.0]	16.34 [415.0]	5.91 [150.0]	3.54 [90.0]
	600	2.83 [72.0]	1.26 [32.0]	0.87 [22.0]	11.02 [280.0]	8.66 [220.0]	18.70 [475.0]	8.46 [215.0]	4.72 [120.0]

All the dimensions are in Inch [Metric]

Lug Pattern Dimensions: 26 to 48 in per API 609

ASME Class 150, 300, and 600

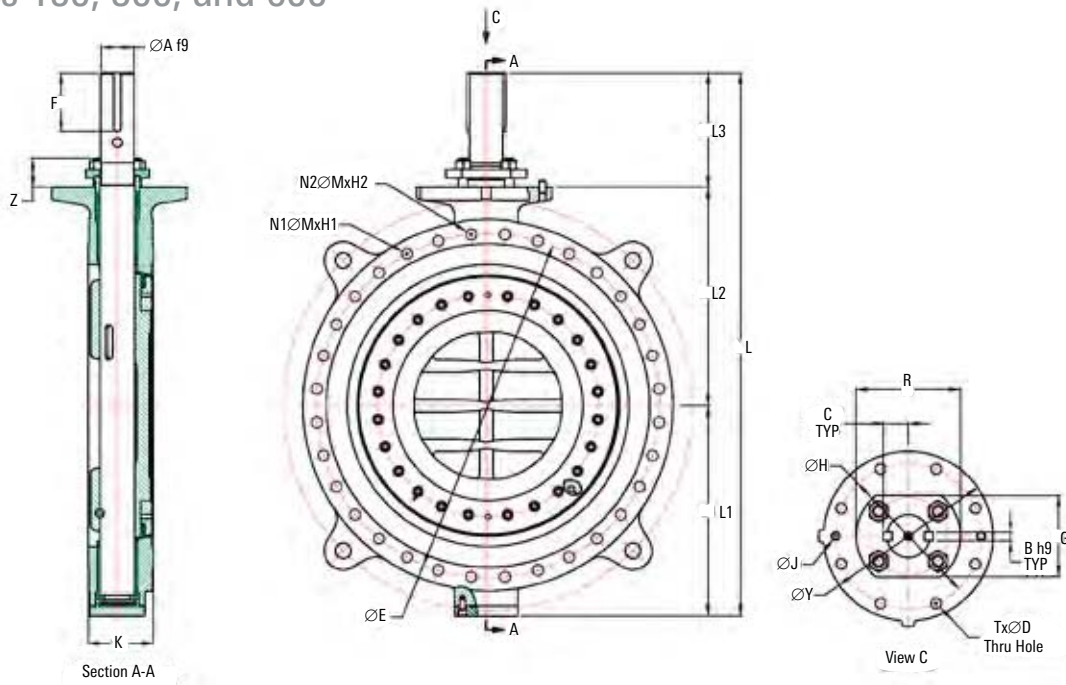

Lug Pattern Dimensions: 26 to 48 in per API 609, ASME Class 150, 300, and 600

Size, in [mm]	Class	ØA f9	B h9	C +0.000/-0.006 [+0.00/-0.15]	Flange Type	ØY	T x ØD THRU HOLE	ØH	ØJ	R	G	L
26 [650]	150	3.15 [80.0]	0.79 [20.0]	1.89 [48.0]	F30	13.78 [350.0]	8 x M20	11.73 [298.0]	0.61 [15.5]	8.86 [225.0]	7.09 [180.0]	52.76 [1,340.0]
	300	3.94 [100.0]	0.87 [22.0]	2.32 [59.0]	F40	18.70 [475.0]	8 x M36	15.98 [406.0]	0.87 [22.0]	10.24 [260.0]	7.87 [200.0]	58.66 [1,490.0]
	600	5.31 [135.0]	1.26 [32.0]	3.17 [80.5]	F48	22.05 [560.0]	12 x M36	19.02 [483.0]	0.98 [25.0]	12.60 [320.0]	9.06 [230.0]	67.72 [1,720.0]
30 [750]	150	3.35 [85.0]	0.87 [22.0]	2.03 [51.5]	F35	16.34 [415.0]	8 x M30	14.02 [356.0]	0.87 [22.0]	8.27 [210.0]	5.91 [150.0]	61.50 [1,562.0]
	300	4.53 [115.0]	1.10 [28.0]	2.70 [68.5]	F40	18.70 [475.0]	8 x M36	15.98 [406.0]	0.87 [22.0]	11.42 [290.0]	8.66 [220.0]	67.20 [1,707.0]
	600	5.71 [145.0]	1.42 [36.0]	3.41 [86.5]	F48	22.05 [560.0]	12 x M36	19.02 [483.0]	0.98 [25.0]	12.99 [330.0]	9.29 [236.0]	72.64 [1,845.0]
32 [800]	150	3.54 [90.0]	0.87 [22.0]	2.13 [54.0]	F35	16.34 [415.0]	8 x M30	14.02 [356.0]	0.87 [22.0]	8.46 [215.0]	6.14 [156.0]	62.72 [1,593.0]
	300	5.12 [130.0]	1.10 [28.0]	2.99 [76.0]	F40	18.70 [475.0]	8 x M36	15.98 [406.0]	0.87 [22.0]	11.02 [280.0]	8.46 [215.0]	69.88 [1,775.0]
	600	6.89 [175.0]	1.42 [36.0]	4.00 [101.5]	F48	22.05 [560.0]	12 x M36	19.02 [483.0]	0.98 [25.0]	14.37 [365.0]	10.63 [270.0]	77.17 [1,960.0]
36 [900]	150	4.13 [105.0]	0.87 [22.0]	2.42 [61.5]	F35	16.34 [415.0]	8 x M30	14.02 [356.0]	0.87 [22.0]	10.04 [255.0]	7.87 [200.0]	67.48 [1,714.0]
	300	5.51 [140.0]	1.10 [28.0]	3.19 [81.0]	F48	22.05 [560.0]	12 x M36	19.02 [483.0]	0.96 [24.5]	12.80 [325.0]	9.06 [230.0]	75.59 [1,920.0]
	600	7.68 [195.0]	1.77 [45.0]	4.51 [114.5]	F60	27.01 [686.0]	20 x M36	23.74 [603.0]	1.18 [30.0]	15.75 [400.0]	11.18 [284.0]	84.84 [2,155.0]
40 [1,000]	150	4.53 [115.0]	1.10 [28.0]	2.70 [68.5]	F40	18.70 [475.0]	8 x M36	15.98 [406.0]	0.87 [22.0]	11.42 [290.0]	8.66 [220.0]	74.21 [1,885.0]
	300	6.30 [160.0]	1.42 [36.0]	3.70 [94.0]	F48	22.05 [560.0]	12 x M36	19.02 [483.0]	0.98 [25.0]	12.80 [325.0]	9.84 [250.0]	79.13 [2,010.0]
	600	8.46 [215.0]	1.77 [45.0]	4.90 [124.5]	F60	27.01 [686.0]	20 x M36	23.74 [603.0]	1.18 [30.0]	18.11 [460.0]	13.86 [352.0]	89.96 [2,285.0]
42 [1,050]	150	5.12 [130.0]	1.10 [28.0]	3.09 [78.5]	F40	18.70 [475.0]	8 x M36	15.98 [406.0]	0.87 [22.0]	11.02 [280.0]	8.46 [215.0]	78.35 [1,990.0]
	300	6.30 [160.0]	1.42 [36.0]	3.70 [94.0]	F48	22.05 [560.0]	12 x M36	19.02 [483.0]	0.98 [25.0]	12.80 [325.0]	9.84 [250.0]	82.36 [2,092.0]
	600	8.66 [220.0]	1.77 [45.0]	5.00 [127.0]	F60	27.01 [686.0]	20 x M36	23.74 [603.0]	1.18 [30.0]	18.11 [460.0]	13.39 [340.0]	93.90 [2,385.0]
46 [1,150]	150	5.51 [140.0]	1.10 [28.0]	3.19 [81.0]	F40	18.70 [475.0]	8 x M36	15.98 [406.0]	0.87 [22.0]	11.42 [290.0]	8.66 [220.0]	82.09 [2,085.0]
	300	6.69 [170.0]	1.10 [28.0]	3.78 [96.0]	F60	27.01 [686.0]	20 x M36	23.74 [603.0]	1.18 [30.0]	14.37 [365.0]	9.84 [250.0]	89.96 [2,285.0]
	600	9.25 [235.0]	1.77 [45.0]	5.30 [134.5]	F60	27.01 [686.0]	20 x M36	23.74 [603.0]	1.18 [30.0]	19.09 [485.0]	14.96 [380.0]	100.24 [2,546.0]
48 [1,200]	150	5.91 [150.0]	1.42 [36.0]	3.50 [89.0]	F40	18.70 [475.0]	8 x M36	15.98 [406.0]	0.87 [22.0]	11.61 [295.0]	9.29 [236.0]	83.27 [2,115.0]
	300	6.69 [170.0]	1.10 [28.0]	3.78 [96.0]	F60	27.01 [686.0]	20 x M36	23.74 [603.0]	1.18 [30.0]	14.37 [365.0]	9.84 [250.0]	90.55 [2,300.0]
	600	9.25 [235.0]	1.77 [45.0]	5.30 [134.5]	F60	27.01 [686.0]	20 x M36	23.74 [603.0]	1.18 [30.0]	19.09 [485.0]	14.96 [380.0]	101.81 [2,586.0]

All the dimensions are in Inch [Metric]

Lug Pattern Dimensions: 26 to 48 in per API 609

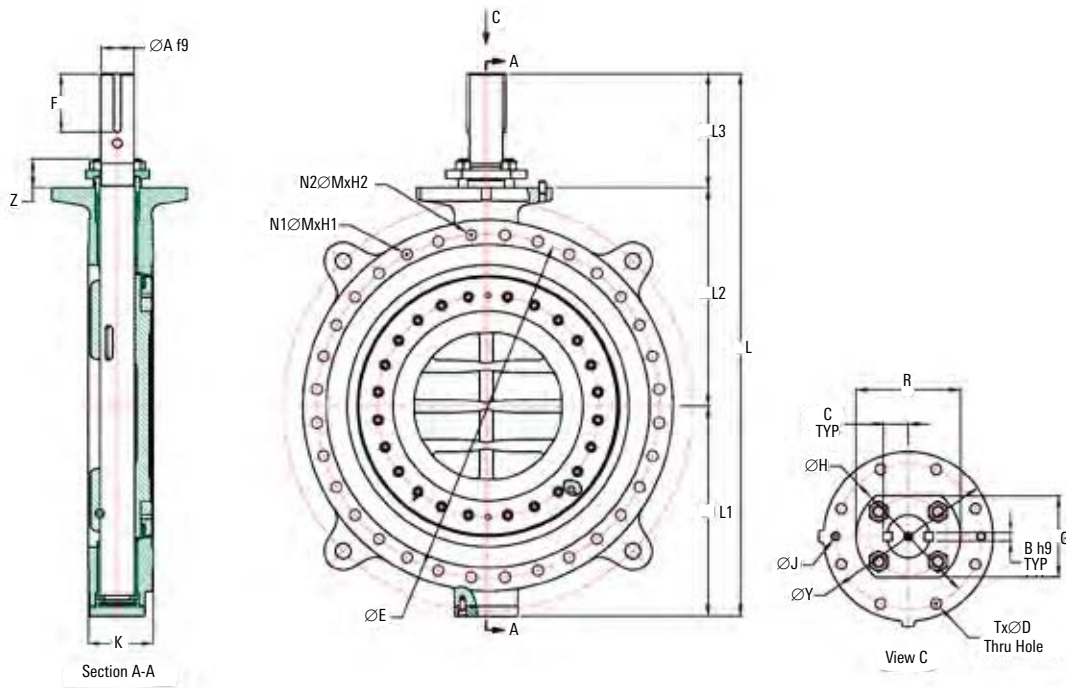

Lug Pattern Dimensions: 26 to 48 in per API 609, ASME Class 150, 300, and 600

Size, in [mm]	Class	L1	L2	L3	ØE	N1 (No's)	ØM	H1	N2 (No's)	H2	K	F	Z
26 [650]	150	19.76 [502.0]	21.65 [550.0]	11.34 [288.0]	31.75 [806.4]	20	1.250-8 UN	1.57 [40.0]	4	1.06 [27.0]	6.69 [170.0]	5.91 [150.0]	3.74 [95.0]
	300	21.57 [548.0]	23.62 [600.0]	13.46 [342.0]	34.50 [876.3]	24	1.625-8 UN	2.05 [52.0]	4	1.18 [30.0]	8.27 [210.0]	5.91 [150.0]	4.13 [105.0]
	600	25.79 [655.0]	25.39 [645.0]	16.54 [420.0]	36.00 [914.4]	20	1.875-8 UN	2.52 [64.0]	8	1.57 [40.0]	11.50 [292.0]	7.87 [200.0]	5.12 [130.0]
30 [750]	150	23.31 [592.0]	25.28 [642.0]	12.91 [328.0]	36.00 [914.4]	24	1.250-8 UN	1.57 [40.0]	4	0.87 [22.0]	6.69 [170.0]	5.91 [150.0]	3.70 [94.0]
	300	25.04 [636.0]	26.54 [674.0]	15.63 [397.0]	39.25 [997.0]	24	1.750-8 UN	2.20 [56.0]	4	1.26 [32.0]	9.25 [235.0]	8.66 [220.0]	4.53 [115.0]
	600	28.35 [720.0]	27.76 [705.0]	16.54 [420.0]	40.25 [1022.4]	20	2.000-8 UN	2.60 [66.0]	8	1.57 [40.0]	12.52 [318.0]	7.87 [200.0]	4.92 [125.0]
32 [800]	150	23.94 [608.0]	25.98 [660.0]	12.80 [325.0]	38.50 [977.9]	24	1.500-8 UN	1.97 [50.0]	4	1.57 [40.0]	9.06 [230.0]	5.91 [150.0]	3.94 [100.0]
	300	26.10 [663.0]	27.56 [700.0]	16.22 [412.0]	41.50 [1,054.1]	24	1.875-8 UN	2.44 [62.0]	4	1.26 [32.0]	9.49 [241.0]	8.66 [220.0]	4.72 [120.0]
	600	30.12 [765.0]	30.51 [775.0]	16.54 [420.0]	42.50 [1,079.5]	20	2.250-8 UN	3.15 [80.0]	8	1.57 [40.0]	12.60 [320.0]	7.87 [200.0]	5.91 [150.0]
36 [900]	150	26.14 [664.0]	27.17 [690.0]	14.17 [360.0]	42.75 [1,085.8]	28	1.500-8 UN	1.97 [50.0]	4	1.10 [28.0]	8.07 [205.0]	7.28 [185.0]	3.74 [95.0]
	300	29.06 [738.0]	29.72 [755.0]	16.81 [427.0]	46.00 [1,168.4]	26	2.000-8 UN	2.58 [65.5]	6	1.35 [34.3]	9.69 [246.0]	8.66 [220.0]	4.72 [120.0]
	600	32.72 [831.0]	32.48 [825.0]	19.65 [499.0]	47.00 [1,193.8]	24	2.500-8 UN	3.19 [81.0]	4	1.69 [43.0]	13.07 [332.0]	10.63 [270.0]	6.69 [170.0]
40 [1,000]	150	28.07 [713.0]	29.92 [760.0]	16.22 [412.0]	47.25 [1,200.2]	32	1.500-8 UN	1.97 [50.0]	4	1.02 [26.0]	9.21 [234.0]	8.66 [220.0]	4.72 [120.0]
	300	30.12 [765.0]	32.48 [825.0]	16.54 [420.0]	45.50 [1,155.7]	24	1.625-8 UN	2.05 [52.0]	8	1.18 [30.0]	11.81 [300.0]	7.87 [200.0]	4.92 [125.0]
	600	33.66 [855.0]	36.81 [935.0]	19.49 [495.0]	47.75 [1,212.8]	24	2.250-8 UN	3.31 [84.0]	8	1.77 [45.0]	16.14 [410.0]	10.63 [270.0]	6.50 [165.0]
42 [1,050]	150	30.91 [785.0]	31.50 [800.0]	15.94 [405.0]	49.50 [1,257.3]	32	1.500-8 UN	1.97 [50.0]	4	1.10 [28.0]	9.88 [251.0]	8.66 [220.0]	5.31 [135.0]
	300	31.69 [805.0]	34.65 [880.0]	16.02 [407.0]	47.50 [1,206.5]	28	1.625-8 UN	2.13 [54.0]	4	1.18 [30.0]	11.81 [300.0]	7.87 [200.0]	5.12 [130.0]
	600	35.83 [910.0]	38.39 [975.0]	19.69 [500.0]	50.50 [1,282.7]	24	2.500-8 UN	3.74 [95.0]	4	1.77 [45.0]	16.14 [410.0]	10.63 [270.0]	6.69 [170.0]
46 [1,150]	150	31.89 [810.0]	33.86 [860.0]	16.34 [415.0]	53.75 [1,365.2]	36	1.500-8 UN	1.97 [50.0]	4	1.50 [38.0]	10.87 [276.0]	8.66 [220.0]	5.31 [135.0]
	300	32.87 [835.0]	37.40 [950.0]	19.69 [500.0]	52.00 [1,320.8]	24	1.875-8 UN	2.36 [60.0]	4	1.89 [48.0]	13.78 [350.0]	10.24 [260.0]	5.12 [130.0]
	600	37.80 [960.0]	41.34 [1,050.0]	21.10 [536.0]	54.75 [1,390.6]	24	2.500-8 UN	3.78 [96.0]	8	2.56 [65.0]	18.50 [470.0]	10.63 [270.0]	6.50 [165.0]
48 [1,200]	150	32.28 [820.0]	35.63 [905.0]	15.35 [390.0]	56.00 [1,422.4]	36	1.500-8 UN	2.28 [58.0]	8	1.10 [28.0]	11.02 [280.0]	7.87 [200.0]	5.31 [135.0]
	300	32.87 [835.0]	37.99 [965.0]	19.69 [500.0]	54.00 [1,371.6]	28	1.875-8 UN	2.36 [60.0]	4	1.89 [48.0]	13.78 [350.0]	10.24 [260.0]	5.12 [130.0]
	600	38.98 [990.0]	42.72 [1,085.0]	20.12 [511.0]	57.50 [1,460.5]	24	2.750-8 UN	3.46 [88.0]	8	2.17 [55.0]	18.50 [470.0]	10.63 [270.0]	6.50 [165.0]

All the dimensions are in Inch [Metric]

Short Pattern Dimensions: 3 to 24 in per ISO 5752/API 609

ASME Class 150, 300, and 600

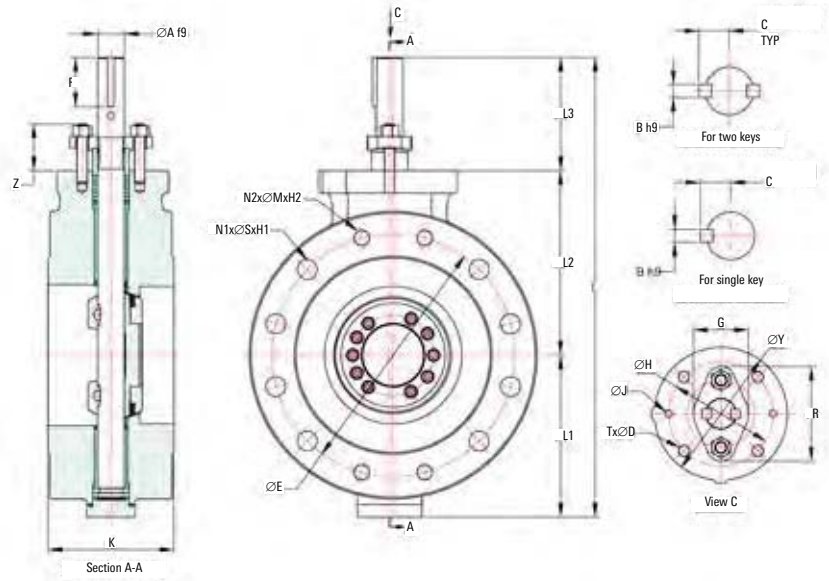

Short Pattern Dimensions: 3 to 24 in per ISO 5752/API 609, ASME Class 150, 300, and 600

Size, in [mm]	Class	ØA f9	B h9	C +0.000/-0.006 [+0.00/-0.15]	NO. OF KEYS	FLANGE TYPE	ØY	T x ØD THRU HOLE	ØH	ØJ
3 [80]	150	0.83 [21.0]	0.24 [6.0]	0.51 [13.0]	1	F07	3.54 [90.0]	4x8x1.25	2.76 [70.0]	0.24 [6.0]
	300	0.83 [21.0]	0.24 [6.0]	0.51 [13.0]	1	F07	3.54 [90.0]	4x8x1.25	2.76 [70.0]	0.24 [6.0]
4 [100]	150	0.83 [21.0]	0.24 [6.0]	0.51 [13.0]	1	F07	3.54 [90.0]	4x8x1.25	2.76 [70.0]	0.24 [6.0]
	300	0.83 [21.0]	0.24 [6.0]	0.51 [13.0]	1	F07	3.54 [90.0]	4x8x1.25	2.76 [70.0]	0.24 [6.0]
	600	1.02 [26.0]	0.32 [8.0]	0.63 [16.0]	1	F12	5.91 [150.0]	4x12x1.75	4.92 [125.0]	0.39 [10.0]
6 [150]	150	0.98 [25.0]	0.32 [8.0]	0.61 [15.5]	1	F10	4.92 [125.0]	4x10x1.50	4.02 [102.0]	0.39 [10.0]
	300	1.18 [30.0]	0.32 [8.0]	0.75 [19.0]	1	F12	5.91 [150.0]	4x12x1.75	4.92 [125.0]	0.39 [10.0]
	600	1.42 [36.0]	0.47 [12.0]	0.91 [23.0]	1	F14	6.89 [175.0]	4x16x2.00	5.51 [140.0]	0.39 [10.0]
8 [200]	150	1.26 [32.0]	0.32 [8.0]	0.75 [19.0]	1	F12	5.91 [150.0]	4x12x1.75	4.92 [125.0]	0.39 [10.0]
	300	1.50 [38.0]	0.39 [10.0]	0.91 [23.0]	2	F14	6.89 [175.0]	4x16x2.00	5.51 [140.0]	0.39 [10.0]
	600	1.81 [46.0]	0.55 [14.0]	1.10 [28.0]	2	F16	8.27 [210.0]	4x20x2.5	6.50 [165.0]	0.47 [12.0]
10 [250]	150	1.42 [36.0]	0.39 [10.0]	0.87 [22.0]	1	F12	5.91 [150.0]	4x12x1.75	4.92 [125.0]	0.39 [10.0]
	300	1.58 [40.0]	0.47 [12.0]	0.97 [24.5]	2	F16	8.27 [210.0]	4x20x2.50	6.50 [165.0]	0.47 [12.0]
	600	2.17 [55.0]	0.63 [16.0]	1.32 [33.5]	2	F25	11.81 [300.0]	8x16x2.0	10.00 [254.0]	0.47 [12.0]
12 [300]	150	1.65 [42.0]	0.47 [12.0]	1.00 [25.5]	1	F14	6.89 [175.0]	4x16x2.00	5.51 [140.0]	0.39 [10.0]
	300	1.81 [46.0]	0.55 [14.0]	1.10 [28.0]	2	F16	8.27 [210.0]	4x20x2.50	6.50 [165.0]	0.47 [12.0]
	600	2.56 [65.0]	0.71 [18.0]	1.56 [39.5]	2	F30	13.78 [350.0]	8x20x2.5	11.73 [298.0]	0.63 [16.0]
14 [350]	150	1.77 [45.0]	0.55 [14.0]	1.10 [28.0]	2	F16	8.27 [210.0]	4x20x2.5	6.50 [165.0]	0.47 [12.0]
	300	2.17 [55.0]	0.63 [16.0]	1.32 [33.5]	2	F25	11.81 [300.0]	8x16x2.0	10.00 [254.0]	0.47 [12.0]
	600	2.95 [75.0]	0.79 [20.0]	1.79 [45.5]	2	F30	13.78 [350.0]	8x20x2.5	11.73 [298.0]	0.63 [16.0]
16 [400]	150	1.97 [50.0]	0.63 [16.0]	1.22 [31.0]	2	F16	8.27 [210.0]	4x20x2.5	6.50 [165.0]	0.47 [12.0]
	300	2.56 [65.0]	0.71 [18.0]	1.56 [39.5]	2	F30	13.78 [350.0]	8x20x2.5	11.73 [298.0]	0.63 [16.0]
	600	3.35 [85.0]	0.87 [22.0]	2.03 [51.5]	2	F35	16.34 [415.0]	8x30x3.5	14.02 [356.0]	0.87 [22.0]
18 [450]	150	2.28 [58.0]	0.71 [18.0]	1.42 [36.0]	2	F25	11.81 [300.0]	8x16x2.0	10.00 [254.0]	0.47 [12.0]
	300	2.76 [70.0]	0.79 [20.0]	1.73 [44.0]	2	F30	13.78 [350.0]	8x20x2.5	11.73 [298.0]	0.63 [16.0]
	600	3.74 [95.0]	0.87 [22.0]	2.22 [56.5]	2	F35	16.34 [415.0]	8x30x3.5	14.02 [356.0]	0.87 [22.0]
20 [500]	150	2.68 [68.0]	0.71 [18.0]	1.61 [41.0]	2	F25	11.81 [300.0]	8x16x2.0	10.00 [254.0]	0.47 [12.0]
	300	3.07 [78.0]	0.87 [22.0]	1.89 [48.0]	2	F35	16.34 [415.0]	8x30x3.5	14.02 [356.0]	0.87 [22.0]
	600	4.13 [105.0]	0.87 [22.0]	2.42 [61.5]	2	F40	18.70 [475.0]	8x36x4.0	15.98 [406.0]	0.87 [22.0]
24 [600]	150	3.07 [78.0]	0.87 [22.0]	1.89 [48.0]	2	F30	13.78 [350.0]	8x20x2.5	11.73 [298.0]	0.63 [16.0]
	300	3.62 [92.0]	0.87 [22.0]	2.17 [55.0]	2	F35	16.34 [415.0]	8x30x3.5	14.02 [356.0]	0.87 [22.0]
	600	5.12 [130.0]	1.10 [28.0]	3.19 [81.0]	2	F40	18.70 [475.0]	8x36x4.0	15.98 [406.0]	0.87 [22.0]

All the dimensions are in Inch [Metric]

Short Pattern Dimensions: 3 to 24 in per ISO 5752/API 609

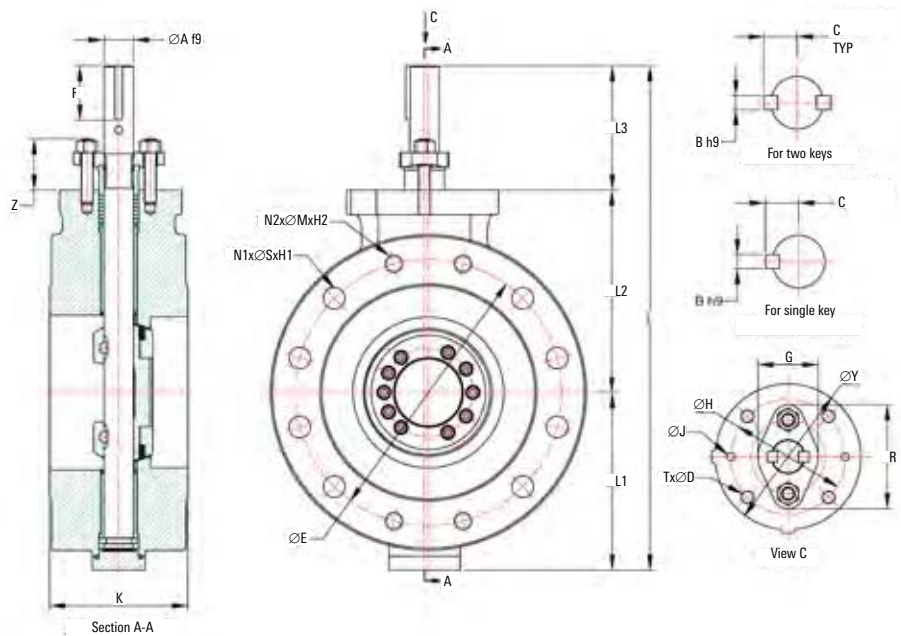

Short Pattern Dimensions: 3 to 24 in per ISO 5752/API 609, ASME Class 150, 300, and 600

Size, in [mm]	Class	R	G	L	L1	L2	L3	ØE	N1 (No's)	ØS
3 [80]	150	2.71 [69.0]	1.34 [34.0]	12.68 [322.0]	4.27 [108.5]	3.94 [100.0]	4.47 [113.5]	6.00 [152.4]	4	.750 [19.00]
	300	2.71 [69.0]	1.34 [34.0]	13.82 [351.0]	4.67 [118.5]	4.72 [120.0]	4.43 [112.5]	6.63 [168.3]	4	.875 [22.00]
4 [100]	150	2.71 [69.0]	1.34 [34.0]	14.65 [372.0]	5.02 [127.5]	5.16 [131.0]	4.47 [113.5]	7.50 [190.5]	4	.750 [19.00]
	300	2.71 [69.0]	1.34 [34.0]	15.63 [397.0]	5.57 [141.5]	5.51 [140.0]	4.55 [115.5]	7.87 [200.0]	4	.875 [22.00]
	600	3.62 [92.0]	1.97 [50.0]	20.00 [508.0]	7.56 [192.0]	7.52 [191.0]	4.92 [125.0]	8.50 [215.9]	4	1.000 [25.40]
6 [150]	150	3.03 [77.0]	1.77 [45.0]	17.09 [434.0]	5.87 [149.0]	6.30 [160.0]	4.92 [125.0]	9.50 [241.3]	4	.875 [22.00]
	300	3.62 [92.0]	1.97 [50.0]	20.12 [511.0]	7.09 [180.0]	8.07 [205.0]	4.96 [126.0]	10.63 [269.9]	8	.875 [22.00]
	600	4.53 [115.0]	2.56 [65.0]	25.59 [650.0]	9.53 [242.0]	10.04 [255.0]	6.02 [153.0]	11.50 [292.0]	8	1.125 [29.00]
8 [200]	150	3.70 [94.0]	1.97 [50.0]	19.76 [502.0]	7.09 [180.0]	7.76 [197.0]	4.92 [125.0]	11.75 [298.5]	4	.875 [22.00]
	300	4.13 [105.0]	2.20 [56.0]	21.79 [553.5]	8.21 [208.5]	8.66 [220.0]	4.92 [125.0]	13.00 [330.2]	8	1.000 [25.00]
	600	5.04 [128.0]	3.15 [80.0]	27.60 [701.0]	10.35 [263.0]	10.71 [272.0]	6.54 [166.0]	13.75 [349.2]	8	1.250 [32.00]
10 [250]	150	4.25 [108.0]	2.36 [60.0]	23.19 [589.0]	8.78 [223.0]	9.33 [237.0]	5.08 [129.0]	14.25 [362.0]	8	1.000 [25.00]
	300	4.96 [126.0]	2.76 [70.0]	26.14 [664.0]	9.69 [246.0]	10.24 [260.0]	6.22 [158.0]	15.25 [387.4]	12	1.125 [29.00]
	600	6.30 [160.0]	3.94 [100.0]	32.32 [821.0]	11.81 [300.0]	12.20 [310.0]	8.31 [211.0]	17.00 [431.8]	12	1.375 [35.00]
12 [300]	150	4.53 [115.0]	2.56 [65.0]	27.01 [686.0]	9.92 [252.0]	10.79 [274.0]	6.30 [160.0]	17.00 [431.8]	8	1.000 [25.00]
	300	4.72 [120.0]	2.95 [75.0]	30.31 [770.0]	11.10 [282.0]	11.81 [300.0]	7.40 [188.0]	17.75 [450.9]	12	1.250 [32.00]
	600	6.10 [155.0]	4.33 [110.0]	34.65 [880.0]	13.27 [337.0]	13.39 [340.0]	7.99 [203.0]	19.25 [489.0]	16	1.375 [35.00]
14 [350]	150	5.43 [138.0]	3.15 [80.0]	32.44 [824.0]	11.26 [286.0]	13.00 [330.0]	8.19 [208.0]	18.75 [476.3]	8	1.125 [29.00]
	300	6.30 [160.0]	3.74 [95.0]	35.91 [912.0]	12.60 [320.0]	13.78 [350.0]	9.53 [242.0]	20.25 [514.4]	16	1.250 [32.00]
	600	7.09 [180.0]	5.32 [135.0]	39.84 [1,012.0]	14.25 [362.0]	14.88 [378.0]	10.71 [272.0]	20.75 [527.0]	12	1.500 [38.00]
16 [400]	150	5.51 [140.0]	3.23 [82.0]	35.28 [896.0]	12.52 [318.0]	14.37 [365.0]	8.39 [213.0]	21.25 [539.8]	12	1.125 [29.00]
	300	6.50 [165.0]	3.94 [100.0]	40.47 [1,028.0]	13.94 [354.0]	15.35 [390.0]	11.18 [284.0]	22.50 [571.5]	16	1.375 [35.00]
	600	8.27 [210.0]	5.91 [150.0]	45.59 [1,158.0]	15.94 [405.0]	16.54 [420.0]	13.11 [333.0]	23.75 [603.2]	12	1.625 [42.00]
18 [450]	150	5.88 [150.0]	3.54 [90.0]	38.47 [977.0]	13.78 [350.0]	15.55 [395.0]	9.13 [232.0]	22.75 [577.9]	12	1.250 [32.00]
	300	7.09 [180.0]	4.13 [105.0]	43.94 [1,116.0]	15.16 [385.0]	17.13 [435.0]	11.65 [296.0]	24.75 [628.6]	20	1.375 [35.00]
	600	9.84 [250.0]	7.09 [180.0]	50.79 [1,290.0]	17.99 [457.0]	18.50 [470.0]	14.29 [363.0]	25.75 [654.0]	12	1.750 [44.50]
20 [500]	150	7.28 [185.0]	4.13 [105.0]	41.65 [1,058.0]	15.12 [384.0]	16.93 [430.0]	9.61 [244.0]	25.00 [635.0]	16	1.250 [32.00]
	300	5.50 [140.0]	7.48 [190.0]	48.74 [1,238.0]	17.05 [433.0]	18.70 [475.0]	13.00 [330.0]	27.00 [685.8]	20	1.375 [35.00]
	600	10.04 [255.0]	7.87 [200.0]	54.49 [1,384.0]	19.17 [487.0]	20.47 [520.0]	14.84 [377.0]	28.50 [723.9]	16	1.750 [44.50]
24 [600]	150	5.12 [130.0]	7.48 [190.0]	48.41 [1,229.5]	17.50 [444.5]	19.29 [490.0]	11.61 [295.0]	29.50 [749.3]	16	1.375 [35.00]
	300	5.91 [150.0]	7.48 [190.0]	55.71 [1,415.0]	19.37 [492.0]	21.46 [545.0]	14.88 [378.0]	32.00 [812.8]	20	1.625 [41.50]
	600	11.02 [280.0]	8.47 [215.0]	59.21 [1,504.0]	21.14 [537.0]	22.24 [565.0]	15.83 [402.0]	33.00 [838.2]	16	2.000 [51.00]

All the dimensions are in Inch [Metric]

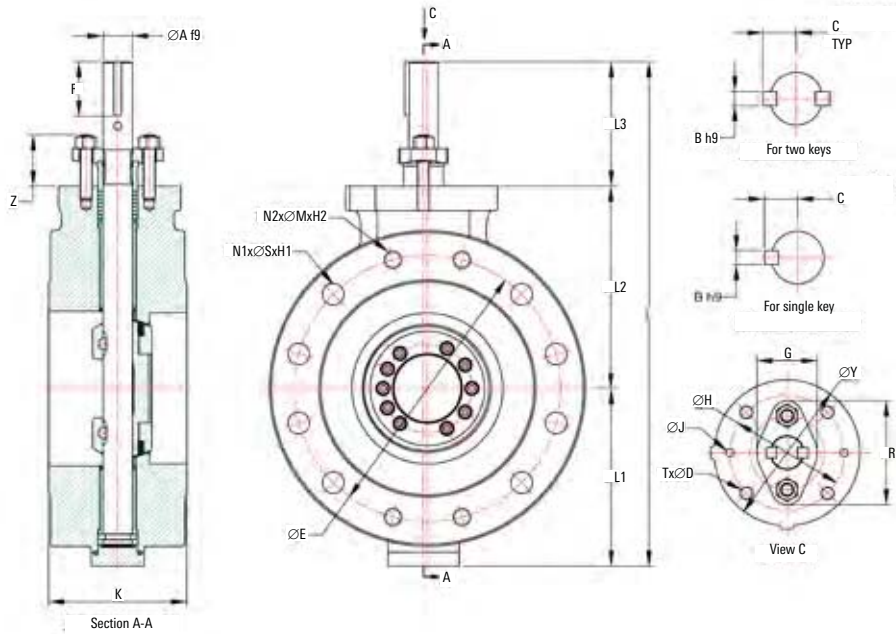

Short Pattern Dimensions: 3 to 24 in per ISO 5752/API 609, ASME Class 150, 300, and 600

Size, in [mm]	Class	H1	N2 (No's)	ØM	H2	K	F	Z
3 [80]	150	0.71 [18.0]	-	-	-	4.50 [114.0]	1.77 [45.0]	1.70 [43.0]
	300	1.06 [27.0]	4	.750-10 UNC	0.87 [22.0]	4.50 [114.0]	1.77 [45.0]	1.70 [43.0]
4 [100]	150	0.91 [23.0]	4	.625-11 UNC	0.91 [23.0]	5.00 [127.0]	1.77 [45.0]	1.70 [43.0]
	300	1.22 [31.0]	4	.750-10 UNC	0.79 [20.0]	5.00 [127.0]	1.77 [45.0]	1.70 [43.0]
6 [150]	600	1.54 [39.0]	4	.875-9 UNC	1.10 [28.0]	7.48 [190.0]	2.17 [55.0]	2.09 [53.0]
	150	0.94 [24.0]	4	.750-10 UNC	0.87 [22.0]	5.50 [140.0]	2.17 [55.0]	1.97 [50.0]
8 [200]	300	1.38 [35.0]	4	.750-10 UNC	0.87 [22.0]	5.50 [140.0]	2.17 [55.0]	2.17 [55.0]
	600	1.89 [48.0]	4	1.00-8 UNC	1.50 [38.0]	8.27 [210.0]	2.17 [55.0]	2.36 [60.0]
10 [250]	150	1.06 [27.0]	4	.750-10 UNC	0.94 [24.0]	6.00 [152.0]	2.17 [55.0]	2.28 [58.0]
	300	1.57 [40.0]	4	.875-9 UNC	0.98 [25.0]	6.00 [152.0]	2.17 [55.0]	2.36 [60.0]
12 [300]	600	2.20 [56.0]	4	1.125-8 UN	1.57 [40.0]	9.06 [230.0]	2.95 [75.0]	2.64 [67.0]
	150	1.14 [29.0]	4	.875-9 UNC	1.02 [26.0]	6.50 [165.0]	2.17 [55.0]	2.36 [60.0]
14 [350]	300	1.85 [47.0]	4	1.000-8 UNC	1.18 [30.0]	6.50 [165.0]	2.76 [70.0]	2.56 [65.0]
	600	2.52 [64.0]	4	1.250-8 UN	1.89 [48.0]	9.84 [250.0]	3.35 [85.0]	3.03 [77.0]
16 [400]	150	1.22 [31.0]	4	.875-9 UNC	1.02 [26.0]	7.00 [178.0]	2.76 [70.0]	2.64 [67.0]
	300	1.97 [50.0]	4	1.125-8 UN	1.38 [35.0]	7.00 [178.0]	3.74 [95.0]	2.76 [70.0]
18 [450]	600	2.64 [67.0]	4	1.250-8 UN	1.77 [45.0]	10.63 [270.0]	3.94 [100.0]	2.95 [75.0]
	150	1.38 [35.0]	4	1.000-8 UNC	1.50 [38.0]	7.48 [190.0]	3.74 [95.0]	3.07 [78.0]
20 [500]	300	2.13 [54.0]	4	1.125-8 UN	1.57 [40.0]	7.48 [190.0]	5.51 [140.0]	3.07 [78.0]
	600	2.76 [70.0]	8	1.375-8 UN	2.05 [52.0]	11.42 [290.0]	5.12 [130.0]	3.27 [83.0]
24 [600]	150	1.46 [37.0]	4	1.000-8 UNC	1.50 [38.0]	8.50 [216.0]	3.94 [100.0]	3.15 [80.0]
	300	2.28 [58.0]	4	1.250-8 UN	1.57 [40.0]	8.50 [216.0]	5.71 [145.0]	3.35 [85.0]
30 [750]	600	3.03 [77.0]	8	1.50-8 UN	2.28 [58.0]	12.20 [310.0]	5.91 [150.0]	3.70 [94.0]
	150	1.57 [40.0]	4	1.125-8 UN	1.57 [40.0]	8.74 [222.0]	4.72 [120.0]	3.27 [83.0]
36 [900]	300	2.40 [61.0]	4	1.250-8 UN	1.57 [40.0]	8.74 [222.0]	6.30 [160.0]	3.39 [86.0]
	600	3.27 [83.0]	8	1.625-8 UN	2.16 [55.0]	12.99 [330.0]	7.28 [185.0]	3.94 [100.0]
42 [1050]	150	1.69 [43.0]	4	1.125-8 UN	1.77 [45.0]	9.02 [229.0]	4.72 [120.0]	3.50 [89.0]
	300	2.52 [64.0]	4	1.250-8 UN	1.57 [40.0]	9.02 [229.0]	6.50 [165.0]	3.46 [88.0]
48 [1200]	600	3.54 [90.0]	8	1.625-8 UN	2.05 [52.0]	13.78 [350.0]	7.28 [185.0]	4.13 [105.0]
	150	1.89 [48.0]	4	1.250-8 UN	1.57 [40.0]	10.51 [267.0]	6.50 [165.0]	3.35 [85.0]
54 [1350]	300	2.76 [70.0]	4	1.500-8 UN	1.97 [50.0]	10.51 [267.0]	8.07 [205.0]	3.54 [90.0]
	600	4.02 [102.0]	8	1.875-8 UN	2.36 [60.0]	15.35 [390.0]	8.66 [220.0]	4.72 [120.0]

All the dimensions are in Inch [Metric]

Short Pattern Dimensions: 26 to 60 in per ISO 5752/API 609

ASME Class 150, 300, and 600

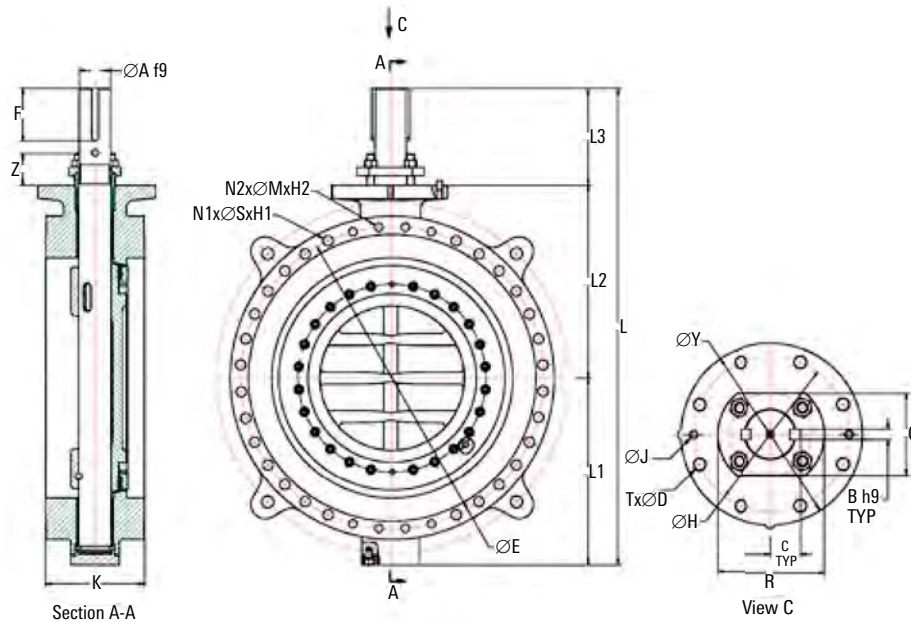

Short Pattern Dimensions: 26 to 60 in per ISO 5752/API 609, ASME Class 150, 300, and 600

Size, in [mm]	Class	ØA f9	B h9	C +0.000/-0.006 [+0.00/-0.15]	Flange Type	ØY	T x ØD THRU HOLE	ØH	ØJ	R	G	L
26 [650]	150	3.15 [80.0]	0.79 [20.0]	1.89 [48.0]	F30	13.78 [350.0]	8 X M20	11.73 [298.0]	0.61 [15.5]	8.86 [225.0]	7.09 [180.0]	52.76 [1,340.0]
	300	3.94 [100.0]	0.87 [22.0]	2.32 [59.0]	F40	18.70 [475.0]	8 x M36	15.98 [406.0]	0.87 [22.0]	10.24 [260.0]	7.87 [200.0]	58.66 [1,490.0]
	600	5.31 [135.0]	1.26 [32.0]	3.17 [80.5]	F48	22.05 [560.0]	12 x M36	19.02 [483.0]	0.98 [25.0]	12.60 [320.0]	9.06 [230.0]	67.72 [1,720.0]
30 [750]	150	3.35 [85.0]	0.87 [22.0]	2.03 [51.5]	F35	16.34 [415.0]	8 X M30	14.02 [356.0]	0.87 [22.0]	8.27 [210.0]	5.91 [150.0]	61.50 [1,562.0]
	300	4.53 [115.0]	1.10 [28.0]	2.70 [68.5]	F40	18.70 [475.0]	8 x M36	15.98 [406.0]	0.87 [22.0]	11.42 [290.0]	8.66 [220.0]	67.20 [1,707.0]
	600	5.71 [145.0]	1.42 [36.0]	3.41 [86.5]	F48	22.05 [560.0]	12 x M36	19.02 [483.0]	0.98 [25.0]	12.99 [330.0]	9.29 [236.0]	72.64 [1,845.0]
32 [800]	150	3.54 [90.0]	0.87 [22.0]	2.13 [54.0]	F35	16.34 [415.0]	8 X M30	14.02 [356.0]	0.87 [22.0]	8.46 [215.0]	6.14 [156.0]	62.72 [1,593.0]
	300	5.12 [130.0]	1.10 [28.0]	2.99 [76.0]	F40	18.70 [475.0]	8 x M36	15.98 [406.0]	0.87 [22.0]	11.02 [280.0]	8.46 [215.0]	69.88 [1,775.0]
	600	6.89 [175.0]	1.42 [36.0]	4.00 [101.5]	F48	22.05 [560.0]	12 x M36	19.02 [483.0]	0.98 [25.0]	14.37 [365.0]	10.63 [270.0]	77.17 [1,960.0]
36 [900]	150	4.13 [105.0]	0.87 [22.0]	2.42 [61.5]	F35	16.34 [415.0]	8 X M30	14.02 [356.0]	0.87 [22.0]	10.04 [255.0]	7.87 [200.0]	67.48 [1,714.0]
	300	5.51 [140.0]	1.10 [28.0]	3.19 [81.0]	F48	22.05 [560.0]	12 x M36	19.02 [483.0]	0.96 [24.5]	12.80 [325.0]	9.06 [230.0]	75.59 [1,920.0]
	600	7.68 [195.0]	1.77 [45.0]	4.51 [114.5]	F60	27.01 [686.0]	20 x M36	23.74 [603.0]	1.18 [30.0]	15.75 [400.0]	11.18 [284.0]	84.84 [2,155.0]
40 [1,000]	150	4.53 [115.0]	1.10 [28.0]	2.70 [68.5]	F40	18.70 [475.0]	8 X M36	15.98 [406.0]	0.87 [22.0]	11.42 [290.0]	8.66 [220.0]	74.21 [1,885.0]
	300	6.30 [160.0]	1.42 [36.0]	3.70 [94.0]	F48	22.05 [560.0]	12 x M36	19.02 [483.0]	0.98 [25.0]	12.80 [325.0]	9.84 [250.0]	79.13 [2,010.0]
	600	8.46 [215.0]	1.77 [45.0]	4.90 [124.5]	F60	27.01 [686.0]	20 x M36	23.74 [603.0]	1.18 [30.0]	18.11 [460.0]	13.86 [352.0]	89.96 [2,285.0]
42 [1,050]	150	5.12 [130.0]	1.10 [28.0]	3.09 [78.5]	F40	18.70 [475.0]	8 X M36	15.98 [406.0]	0.87 [22.0]	11.02 [280.0]	8.46 [215.0]	78.35 [1,990.0]
	300	6.30 [160.0]	1.42 [36.0]	3.70 [94.0]	F48	22.05 [560.0]	12 x M36	19.02 [483.0]	0.98 [25.0]	12.80 [325.0]	9.84 [250.0]	82.36 [2,092.0]
	600	8.66 [220.0]	1.77 [45.0]	5.00 [127.0]	F60	27.01 [686.0]	20 x M36	23.74 [603.0]	1.18 [30.0]	18.11 [460.0]	13.39 [340.0]	93.90 [2,385.0]
46 [1,150]	150	5.51 [140.0]	1.10 [28.0]	3.19 [81.0]	F40	18.70 [475.0]	8 X M36	15.98 [406.0]	0.87 [22.0]	11.42 [290.0]	8.66 [220.0]	82.09 [2,085.0]
	300	6.69 [170.0]	1.10 [28.0]	3.78 [96.0]	F60	27.01 [686.0]	20 x M36	23.74 [603.0]	1.18 [30.0]	14.37 [365.0]	9.84 [250.0]	89.96 [2,285.0]
	600	9.25 [235.0]	1.77 [45.0]	5.30 [134.5]	F60	27.01 [686.0]	20 x M36	23.74 [603.0]	1.18 [30.0]	19.09 [485.0]	14.96 [380.0]	100.24 [2,546.0]

All the dimensions are in Inch [Metric]

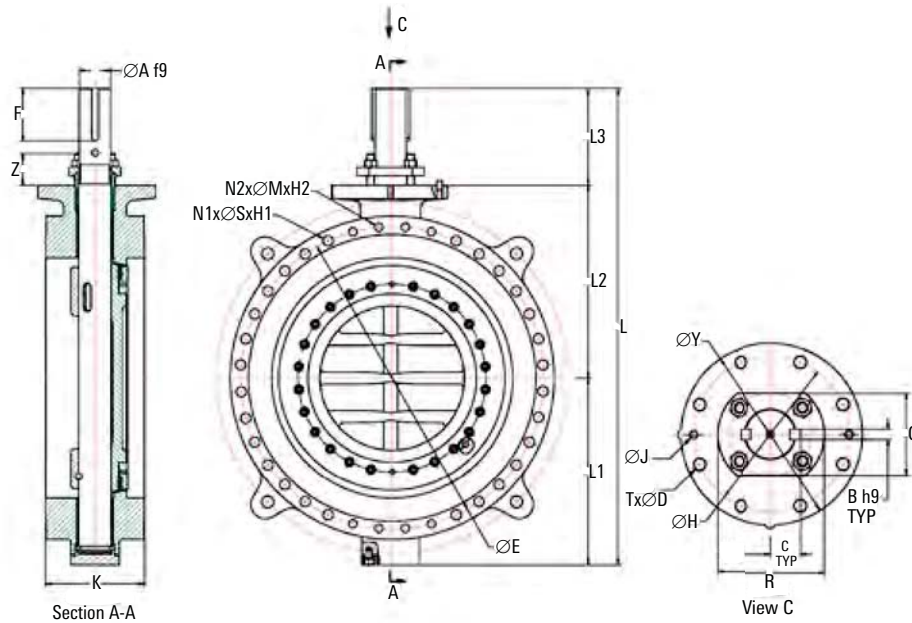

Short Pattern Dimensions: 26 to 60 in per ISO 5752/API 609, ASME Class 150, 300, and 600

Size, in [mm]	Class	ØA f9	B h9	C +0.000/-0.006	Flange Type	ØY	T x ØD THRU HOLE	ØH	ØJ	R	G	L
48 [1,200]	150	5.91 [150.0]	1.42 [36.0]	3.50 [89.0]	F40	18.70 [475.0]	8 X M36	15.98 [406.0]	0.87 [22.0]	11.61 [295.0]	9.29 [236.0]	83.27 [2,115.0]
	300	6.69 [170.0]	1.10 [28.0]	3.78 [96.0]	F60	27.01 [686.0]	20 x M36	23.74 [603.0]	1.18 [30.0]	14.37 [365.0]	9.84 [250.0]	90.55 [2,300.0]
	600	9.25 [235.0]	1.77 [45.0]	5.30 [134.5]	F60	27.01 [686.0]	20 x M36	23.74 [603.0]	1.18 [30.0]	19.09 [485.0]	14.96 [380.0]	101.81 [2,586.0]
52 [1,300]	150	6.50 [165.0]	1.42 [36.0]	3.80 [96.5]	F48	22.05 [560.0]	12 X M36	19.02 [483.0]	0.98 [25.0]	13.19 [335.0]	10.24 [260.0]	90.94 [2,310.0]
	300	8.07 [205.0]	1.77 [45.0]	4.70 [119.5]	F60	27.01 [686.0]	20 x M36	23.74 [603.0]	1.18 [30.0]	16.93 [430.0]	12.99 [330.0]	98.82 [2,510.0]
	600	11.61 [295.0]	2.48 [63.0]	6.87 [174.5]	F80	35.43 [900.0]	20 x M42	32.01 [813.0]	1.38 [35.0]	21.65 [550.0]	15.75 [400.0]	114.17 [2,900.0]
54 [1,350]	150	6.69 [170.0]	1.42 [36.0]	3.90 [99.0]	F48	22.05 [560.0]	12 X M36	19.02 [483.0]	0.98 [25.0]	14.37 [365.0]	9.84 [250.0]	93.90 [2,385.0]
	300	8.46 [215.0]	1.77 [45.0]	4.90 [124.5]	F60	27.01 [686.0]	20 x M36	23.74 [603.0]	1.18 [30.0]	18.11 [460.0]	13.86 [352.0]	101.18 [2,570.0]
	600	12.60 [320.0]	2.48 [63.0]	7.36 [187.0]	F80	35.43 [900.0]	20 x M42	32.01 [813.0]	1.38 [35.0]	22.44 [570.0]	—	119.21 [3,028.0]
56 [1,400]	150	7.09 [180.0]	1.42 [36.0]	4.09 [104.0]	F48	22.05 [560.0]	12 X M36	19.02 [483.0]	0.98 [25.0]	14.37 [365.0]	11.02 [280.0]	97.64 [2,480.0]
	300	8.86 [225.0]	1.77 [45.0]	5.10 [129.5]	F60	27.01 [686.0]	20 x M36	23.74 [603.0]	1.18 [30.0]	16.14 [410.0]	11.42 [290.0]	107.09 [2,720.0]
	600	13.19 [335.0]	2.76 [70.0]	7.78 [197.5]	F80	35.43 [900.0]	20 x M42	32.01 [813.0]	1.38 [35.0]	23.23 [590.0]	—	126.38 [3,210.0]
58 [1,450]	150	7.48 [190.0]	1.57 [40.0]	4.33 [110.0]	F48	22.05 [560.0]	12 X M36	19.02 [483.0]	0.98 [25.0]	14.37 [365.0]	11.42 [290.0]	102.95 [2,615.0]
	300	9.45 [240.0]	1.77 [45.0]	5.39 [137.0]	F60	27.01 [686.0]	20 x M36	23.74 [603.0]	1.18 [30.0]	18.70 [475.0]	14.17 [360.0]	110.63 [2,810.0]
	600	13.58 [345.0]	2.76 [70.0]	7.97 [202.5]	F80	35.43 [900.0]	20 x M42	32.01 [813.0]	1.38 [35.0]	25.20 [640.0]	—	129.65 [3,293.0]
60 [1,500]	150	8.46 [215.0]	1.77 [45.0]	4.90 [124.5]	F48	22.05 [560.0]	12 X M36	19.02 [483.0]	0.98 [25.0]	15.16 [385.0]	12.20 [310.0]	103.74 [2,635.0]
	300	10.04 [255.0]	1.97 [50.0]	5.77 [146.5]	F60	27.01 [686.0]	20 x M36	23.74 [603.0]	1.18 [30.0]	18.70 [475.0]	14.76 [375.0]	115.55 [2,935.0]
	600	13.98 [355.0]	2.76 [70.0]	8.17 [207.5]	F80	35.43 [900.0]	20 x M42	32.01 [813.0]	1.38 [35.0]	24.41 [620.0]	—	134.06 [3,405.0]

All the dimensions are in Inch [Metric]

Short Pattern Dimensions: 26 to 60 in per ISO 5752/API 609

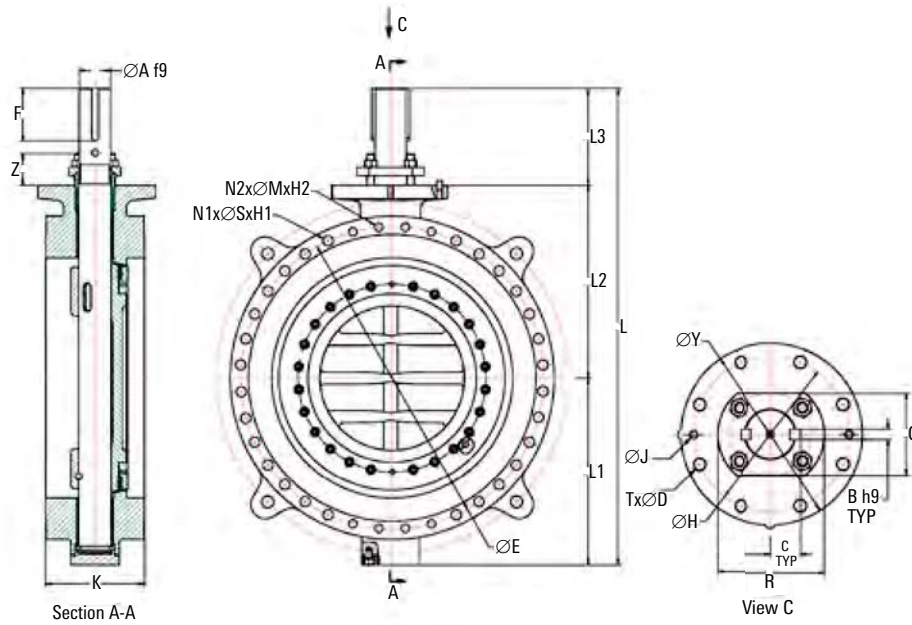

Short Pattern Dimensions: 26 to 60 in per ISO 5752/API 609, AMSE Class 150, 300, and 600

Size, in [mm]	Class	L1	L2	L3	ØE	N1 (No's)	ØS	H1	N2 (No's)	ØM	H2	K	F	Z
26 [650]	150	19.76 [502.0]	21.65 [550.0]	11.34 [288.0]	31.75 [806.4]	20	1.38 [35.0]	2.68 [68.0]	4	1.250-8 UN	1.57 [40.0]	11.50 [292.0]	5.91 [150.0]	3.74 [95.0]
	300	21.57 [548.0]	23.62 [600.0]	13.46 [342.0]	34.50 [876.3]	20	1.75 [44.5]	3.15 [80.0]	8	1.625-8 UN	1.77 [45.0]	11.50 [292.0]	5.91 [150.0]	4.13 [105.0]
	600	25.79 [655.0]	25.39 [645.0]	16.54 [420.0]	36.00 [914.4]	20	2.01 [51.0]	4.33 [110.0]	8	1.875-8 UN	2.36 [60.0]	16.93 [430.0]	7.87 [200.0]	5.12 [130.0]
30 [750]	150	23.31 [592.0]	25.28 [642.0]	12.91 [328.0]	36.00 [914.4]	24	1.38 [35.0]	3.17 [80.5]	4	1.250-8 UN	1.57 [40.0]	12.52 [318.0]	5.91 [150.0]	3.70 [94.0]
	300	25.04 [636.0]	26.54 [674.0]	15.63 [397.0]	39.25 [997.0]	22	1.89 [48.0]	3.70 [94.0]	6	1.750-8 UN	2.17 [55.0]	12.52 [318.0]	8.66 [220.0]	4.53 [115.0]
	600	28.35 [720.0]	27.76 [705.0]	16.54 [420.0]	40.25 [1022.4]	20	2.13 [54.0]	4.61 [117.0]	8	2.000-8 UN	2.56 [65.0]	16.93 [430.0]	7.87 [200.0]	4.92 [125.0]
32 [800]	150	23.94 [608.0]	25.98 [660.0]	12.80 [325.0]	38.50 [977.9]	24	1.65 [42.0]	3.19 [81.0]	4	1.500-8 UN	1.97 [50.0]	12.52 [318.0]	5.91 [150.0]	3.94 [100.0]
	300	26.10 [663.0]	27.56 [700.0]	16.22 [412.0]	41.50 [1,054.1]	20	2.01 [51.0]	3.90 [99.0]	8	1.875-8 UN	1.97 [50.0]	12.52 [318.0]	8.66 [220.0]	4.72 [120.0]
	600	30.12 [765.0]	30.51 [775.0]	16.54 [420.0]	42.50 [1,079.5]	20	2.40 [61.0]	4.72 [120.0]	8	2.250-8 UN	2.76 [70.0]	18.50 [470.0]	7.87 [200.0]	5.91 [150.0]
36 [900]	150	26.14 [664.0]	27.17 [690.0]	14.17 [360.0]	42.75 [1,085.8]	28	1.65 [42.0]	3.80 [96.5]	4	1.500-8 UN	1.97 [50.0]	12.99 [330.0]	7.28 [185.0]	3.54 [90.0]
	300	29.06 [738.0]	29.72 [755.0]	16.81 [427.0]	46.00 [1,168.4]	24	2.13 [54.0]	4.25 [108.0]	8	2.000-8 UN	2.36 [60.0]	12.99 [330.0]	8.66 [220.0]	4.72 [120.0]
	600	32.72 [831.0]	32.48 [825.0]	19.65 [499.0]	47.00 [1,193.8]	20	2.64 [67.0]	4.96 [126.0]	8	2.500-8 UN	2.56 [65.0]	20.08 [510.0]	10.63 [270.0]	6.69 [170.0]
40 [1,000]	150	28.07 [713.0]	29.92 [760.0]	16.22 [412.0]	47.25 [1,200.2]	28	1.63 [41.5]	3.62 [92.0]	8	1.500-8 UN	1.97 [50.0]	16.14 [410.0]	8.66 [220.0]	4.72 [120.0]
	300	30.12 [765.0]	32.48 [825.0]	16.54 [420.0]	45.50 [1,155.7]	24	1.77 [45.0]	4.53 [115.0]	8	1.625-8 UN	1.97 [50.0]	16.14 [410.0]	7.87 [200.0]	4.92 [125.0]
	600	33.66 [855.0]	36.81 [935.0]	19.49 [495.0]	47.75 [1,212.8]	24	2.40 [61.0]	6.34 [161.0]	8	2.250-8 UN	2.76 [70.0]	21.65 [550.0]	10.63 [270.0]	6.50 [165.0]
42 [1,050]	150	30.91 [785.0]	31.50 [800.0]	15.94 [405.0]	49.50 [1,257.3]	28	1.63 [41.5]	3.94 [100.0]	8	1.500-8 UN	1.57 [40.0]	16.14 [410.0]	8.66 [220.0]	5.31 [135.0]
	300	31.69 [805.0]	34.65 [880.0]	16.02 [407.0]	47.50 [1,206.5]	24	1.75 [44.5]	4.80 [122.0]	8	1.625-8 UN	1.75 [44.5]	16.14 [410.0]	7.87 [200.0]	5.12 [130.0]
	600	35.83 [910.0]	38.39 [975.0]	19.69 [500.0]	50.50 [1,282.7]	20	2.64 [67.0]	6.73 [171.0]	8	2.500-8 UN	2.56 [65.0]	21.65 [550.0]	10.63 [270.0]	6.69 [170.0]
46 [1,150]	150	31.89 [810.0]	33.86 [860.0]	16.34 [415.0]	53.75 [1,365.2]	32	1.63 [41.5]	4.13 [105.0]	8	1.500-8 UN	1.97 [50.0]	18.50 [470.0]	8.66 [220.0]	5.31 [135.0]
	300	32.87 [835.0]	37.40 [950.0]	19.69 [500.0]	52.00 [1,320.8]	24	2.01 [51.0]	5.12 [130.0]	4	1.875-8 UN	2.36 [60.0]	18.50 [470.0]	10.24 [260.0]	5.12 [130.0]
	600	37.80 [960.0]	41.34 [1,050.0]	21.10 [536.0]	54.75 [1,390.6]	24	2.64 [67.0]	7.17 [182.0]	8	2.500-8 UN	2.95 [75.0]	24.80 [630.0]	10.63 [270.0]	6.50 [165.0]

All the dimensions are in Inch [Metric]

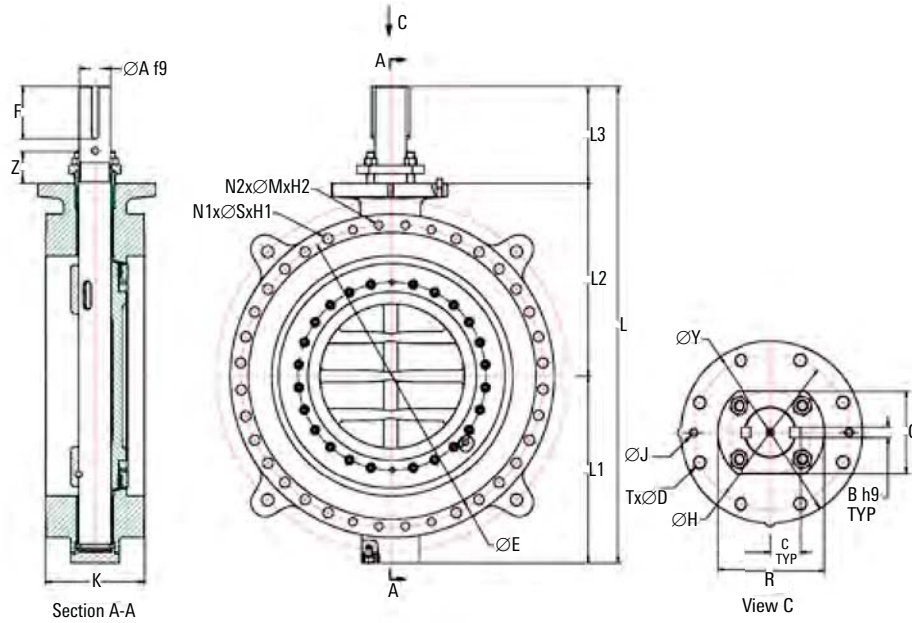

Short Pattern Dimensions: 26 to 60 in per ISO 5752/API 609, AMSE Class 150, 300, and 600

Size, in [mm]	Class	L1	L2	L3	ØE	N1 (No's) ØS	H1	N2 (No's) ØM	H2	K	F	Z
48 [1,200]	150	32.28 [820.0]	35.63 [905.0]	15.35 [390.0]	56.00 [1,422.4]	36 1.63 [41.5]	4.33 [110.0]	8 1.500-8 UN	1.57 [40.0]	18.50 [470.0]	7.87 [200.0]	5.31 [135.0]
	300	32.87 [835.0]	37.99 [965.0]	19.69 [500.0]	54.00 [1,371.6]	24 2.01 [51.0]	5.43 [138.0]	8 1.875-8 UN	2.76 [70.0]	18.50 [470.0]	10.24 [260.0]	5.12 [130.0]
	600	38.98 [990.0]	42.72 [1085.0]	20.12 [511.0]	57.50 [1,460.5]	24 2.87 [73.0]	7.52 [191.0]	8 2.750-8 UN	3.15 [80.0]	24.80 [630.0]	10.63 [270.0]	6.50 [165.0]
52 [1,300]	150	36.22 [920.0]	38.19 [970.0]	16.54 [420.0]	60.50 [1,536.7]	36 1.89 [48.0]	4.65 [118.0]	8 1.750-8 UN	2.17 [55.0]	20.87 [530.0]	7.87 [200.0]	5.12 [130.0]
	300	38.19 [970.0]	41.34 [1,050.0]	19.29 [490.0]	58.25 [1,479.6]	24 2.13 [54.0]	5.75 [146.0]	8 2.000-8 UN	2.17 [55.0]	20.87 [530.0]	9.84 [250.0]	6.10 [155.0]
	600	43.07 [1094.0]	47.05 [1,195.0]	24.06 [611.0]	62.00 [1,574.8]	24 3.15 [80.0]	8.11 [206.0]	8 3.000-8 UN	3.15 [80.0]	26.77 [680.0]	13.78 [350.0]	8.46 [215.0]
54 [1,350]	150	37.60 [955.0]	39.76 [1,010.0]	16.54 [420.0]	62.75 [1,593.8]	36 1.89 [48.0]	4.84 [123.0]	8 1.750-8 UN	2.36 [60.0]	20.87 [530.0]	7.87 [200.0]	5.12 [130.0]
	300	39.37 [1,000.0]	43.31 [1,100.0]	18.50 [470.0]	61.00 [1,549.4]	24 2.38 [60.5]	6.06 [154.0]	4 2.250-8 UN	2.36 [60.0]	20.87 [530.0]	9.06 [230.0]	6.50 [165.0]
	600	46.54 [1,182.0]	48.23 [1,225.0]	24.45 [621.0]	64.25 [1,632.0]	24 3.15 [80.0]	8.35 [212.0]	8 3.000-8 UN	3.07 [78.0]	27.95 [710.0]	14.17 [360.0]	8.66 [220.0]
56 [1,400]	150	38.58 [980.0]	40.16 [1,020.0]	18.90 [480.0]	65.00 [1,651.0]	40 1.89 [48.0]	4.96 [126.0]	8 1.750-8 UN	2.76 [70.0]	20.87 [530.0]	10.24 [260.0]	6.10 [155.0]
	300	40.75 [1,035.0]	45.28 [1,150.0]	21.06 [535.0]	63.00 [1,600.2]	24 2.38 [60.5]	6.14 [156.0]	4 2.250-8 UN	2.76 [70.0]	20.87 [530.0]	11.81 [300.0]	6.30 [160.0]
	600	48.19 [1,224.0]	50.79 [1,290.0]	27.40 [696.0]	66.75 [1,695.4]	24 3.39 [86.0]	8.66 [220.0]	8 3.250-8 UN	3.94 [100.0]	27.95 [710.0]	14.76 [375.0]	8.66 [220.0]
58 [1,450]	150	39.17 [995.0]	42.32 [1,075.0]	21.46 [545.0]	67.25 [1,708.2]	40 1.89 [48.0]	5.12 [130.0]	8 1.750-8 UN	2.36 [60.0]	23.62 [600.0]	12.80 [325.0]	6.10 [155.0]
	300	42.13 [1,070.0]	46.26 [1,175.0]	22.24 [565.0]	65.00 [1,651.0]	24 2.38 [60.5]	6.34 [161.0]	8 2.250-8 UN	2.95 [75.0]	23.62 [600.0]	12.80 [325.0]	6.50 [165.0]
	600	49.33 [1,253.0]	52.36 [1,330.0]	27.95 [710.0]	68.75 [1,746.2]	24 3.39 [86.0]	8.86 [225.0]	8 3.250-8 UN	3.94 [100.0]	31.10 [790.0]	15.75 [400.0]	8.86 [225.0]
60 [1,500]	150	41.14 [1,045.0]	44.09 [1,120.0]	18.50 [470.0]	69.25 [1,759.0]	44 1.89 [48.0]	5.28 [134.0]	8 1.750-8 UN	2.36 [60.0]	23.62 [600.0]	9.84 [250.0]	6.30 [160.0]
	300	45.24 [1,149.0]	48.03 [1,220.0]	22.28 [566.0]	67.00 [1,701.8]	24 2.36 [60.0]	6.67 [169.5]	8 2.250-8 UN	2.95 [75.0]	23.62 [600.0]	12.80 [325.0]	7.28 [185.0]
	600	52.32 [1,329.0]	53.74 [1,365.0]	27.99 [711.0]	71.75 [1,822.4]	20 3.62 [92.0]	9.72 [247.0]	8 3.500-8 UN	4.53 [115.0]	30.71 [780.0]	15.75 [400.0]	9.65 [245.0]

All the dimensions are in Inch [Metric]

Long Pattern Dimensions: 3 to 24 in per ASME B16.10 and API 609

ASME Class 150 and 300

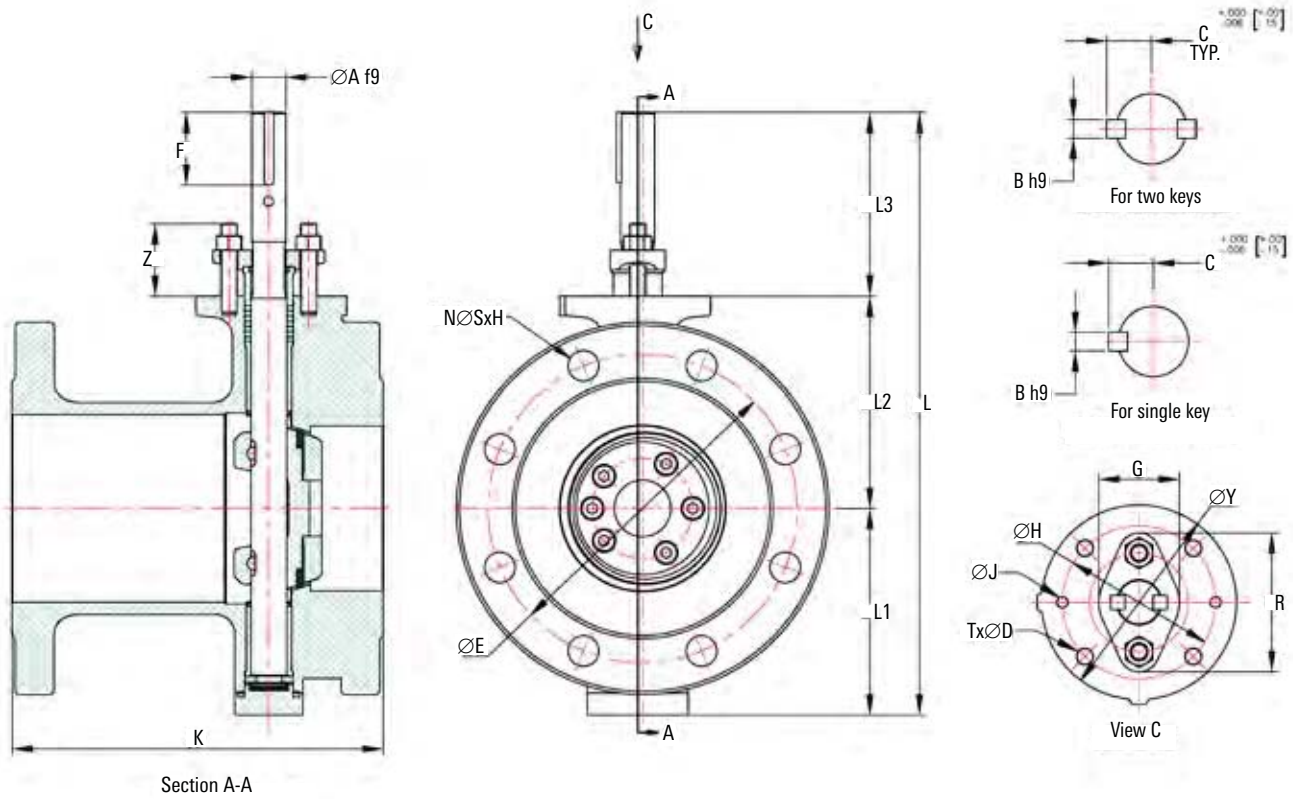

Long Pattern Dimensions: 3 to 24 in per ASME B16.10 and API 609, ASME Class 150 and 300

Size, in [mm]	Class	ØA f9	B h9	C +0.000/-0.006 [+0.00/-0.15]	NO. of keys	FLANGE TYPE	ØE	F	ØH	ØJ	K	L
3 [80]	150	0.83 [21.0]	0.24 [6.0]	0.51 [13.0]	1	F07	6.00 [152.4]	1.77 [45.0]	2.76 [70.0]	0.24 [6.0]	8.00 [203.0]	12.68 [322.0]
	300	0.83 [21.0]	0.24 [6.0]	0.51 [13.0]	1	F07	6.62 [168.3]	1.77 [45.0]	2.76 [70.0]	0.24 [6.0]	11.12 [282.0]	13.82 [351.0]
4 [100]	150	0.83 [21.0]	0.24 [6.0]	0.51 [13.0]	1	F07	7.50 [190.5]	1.77 [45.0]	2.76 [70.0]	0.24 [6.0]	9.00 [229.0]	14.65 [372.0]
	300	0.83 [21.0]	0.24 [6.0]	0.51 [13.0]	1	F07	7.88 [200.0]	1.77 [45.0]	2.76 [70.0]	0.24 [6.0]	12.00 [305.0]	15.63 [397.0]
6 [150]	150	0.98 [25.0]	0.31 [8.0]	0.61 [15.5]	1	F10	10.62 [269.9]	2.17 [55.0]	4.02 [102.0]	0.39 [10.0]	10.50 [267.0]	17.09 [434.0]
	300	1.18 [30.0]	0.31 [8.0]	0.75 [19.0]	1	F12	10.62 [269.9]	2.17 [55.0]	4.92 [125.0]	0.39 [10.0]	15.88 [403.0]	20.12 [511.0]
8 [200]	150	1.26 [32.0]	0.31 [8.0]	0.75 [19.0]	1	F12	11.75 [298.5]	2.17 [55.0]	4.92 [125.0]	0.39 [10.0]	11.50 [292.0]	19.76 [502.0]
	300	1.50 [38.0]	0.39 [10.0]	0.91 [23.0]	2	F14	13.00 [330.2]	2.17 [55.0]	5.51 [140.0]	0.39 [10.0]	16.50 [418.0]	21.79 [553.5]
10 [250]	150	1.42 [36.0]	0.39 [10.0]	0.87 [22.0]	1	F12	14.25 [362.0]	2.17 [55.0]	4.92 [125.0]	0.39 [10.0]	13.00 [330.0]	23.19 [589.0]
	300	1.57 [40.0]	0.47 [12.0]	0.96 [24.5]	2	F16	15.25 [387.4]	2.76 [70.0]	6.50 [165.0]	0.47 [12.0]	18.00 [457.0]	26.14 [664.0]
12 [300]	150	1.65 [42.0]	0.47 [12.0]	1.00 [25.5]	1	F14	17.00 [431.8]	2.76 [70.0]	5.51 [140.0]	0.39 [10.0]	14.00 [356.0]	27.01 [686.0]
	300	1.81 [46.0]	0.55 [14.0]	1.10 [28.0]	2	F16	17.75 [450.9]	3.74 [95.0]	6.50 [165.0]	0.47 [12.0]	19.75 [502.0]	30.31 [770.0]
14 [350]	150	1.77 [45.0]	0.55 [14.0]	1.10 [28.0]	2	F16	18.75 [476.3]	3.74 [95.0]	6.50 [165.0]	0.47 [12.0]	15.00 [381.0]	32.44 [824.0]
	300	2.17 [55.0]	0.63 [16.0]	1.32 [33.5]	2	F25	20.25 [514.4]	5.51 [140.0]	10.00 [254.0]	0.47 [12.0]	30.00 [762.0]	35.91 [912.0]
16 [400]	150	1.97 [50.0]	0.63 [16.0]	1.22 [31.0]	2	F16	21.25 [539.8]	3.94 [100.0]	6.50 [165.0]	0.47 [12.0]	16.00 [406.0]	35.28 [896.0]
	300	2.56 [65.0]	0.71 [18.0]	1.56 [39.5]	2	F30	22.50 [571.5]	5.71 [145.0]	11.73 [298.0]	0.63 [16.0]	33.00 [838.0]	40.47 [1,028.0]
18 [450]	150	2.28 [58.0]	0.71 [18.0]	1.42 [36.0]	2	F25	22.75 [577.9]	4.72 [120.0]	10.00 [254.0]	0.47 [12.0]	17.00 [432.0]	38.46 [977.0]
	300	2.76 [70.0]	0.79 [20.0]	1.73 [44.0]	2	F30	24.75 [628.6]	6.30 [160.0]	11.73 [298.0]	0.63 [16.0]	36.00 [914.0]	43.94 [1,116.0]
20 [500]	150	2.68 [68.0]	0.71 [18.0]	1.61 [41.0]	2	F25	25.00 [635.0]	4.72 [120.0]	10.00 [254.0]	0.47 [12.0]	18.00 [457.0]	41.65 [1,058.0]
	300	3.07 [78.0]	0.87 [22.0]	1.89 [48.0]	2	F35	27.00 [688.8]	6.50 [165.0]	14.02 [356.0]	0.87 [22.0]	39.00 [991.0]	48.74 [1,238.0]
24 [600]	150	3.07 [78.0]	0.87 [22.0]	1.89 [48.0]	2	F30	29.50 [749.3]	6.50 [165.0]	11.73 [298.0]	0.63 [16.0]	20.00 [508.0]	48.39 [1,229.5]
	300	3.62 [92.0]	0.87 [22.0]	2.17 [55.0]	2	F35	32.00 [812.8]	8.07 [205.0]	14.02 [356.0]	0.87 [22.0]	45.00 [1,143.0]	55.71 [1,415.0]

All the dimensions are in Inch [Metric]

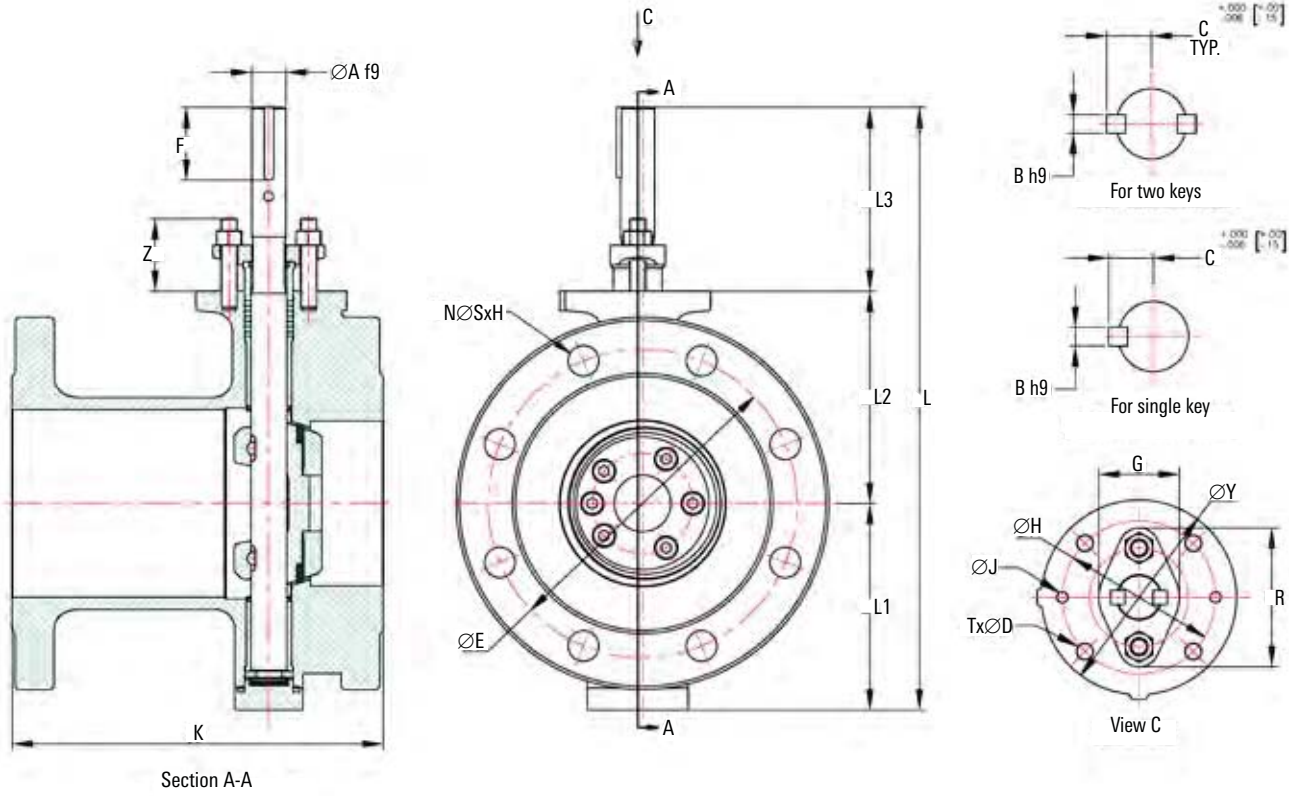

Long Pattern Dimensions: 3 to 24 in per ASME B16.10 and API 609, ASME Class 150 and 300

Size, in [mm]	Class	L1	L2	L3	N	ØS	H	T x ØD THRU HOLE	G	R	ØY	Z
3 [80]	150	4.27 [108.5]	3.94 [100.0]	4.47 [113.5]	4	0.750 [19.00]	0.71 [18.0]	4 X M8x1.25	1.34 [34.0]	2.71 [69.0]	3.54 [90.0]	1.70 [43.0]
	300	4.67 [118.5]	4.72 [120.0]	4.43 [112.5]	8	0.875 [22.00]	1.06 [27.0]	4 X M8x1.25	1.34 [34.0]	2.71 [69.0]	3.54 [90.0]	1.70 [43.0]
4 [100]	150	5.02 [127.5]	5.16 [131.0]	4.47 [113.5]	8	0.750 [19.00]	0.91 [23.0]	4 X M8x1.25	1.34 [34.0]	2.71 [69.0]	3.54 [90.0]	1.70 [43.0]
	300	5.57 [141.5]	5.51 [140.0]	4.55 [115.5]	8	0.875 [22.00]	1.22 [31.0]	4 X M8x1.25	1.34 [34.0]	2.71 [69.0]	3.54 [90.0]	1.70 [43.0]
6 [150]	150	5.87 [149.0]	6.30 [160.0]	4.92 [125.0]	8	0.875 [22.00]	0.94 [24.0]	4 X M10x1.50	1.77 [45.0]	3.03 [77.0]	4.92 [125.0]	1.97 [50.0]
	300	7.09 [180.0]	8.07 [205.0]	4.96 [126.0]	12	0.875 [22.00]	1.38 [35.0]	4 X M12x1.75	1.97 [50.0]	3.62 [92.0]	5.91 [150.0]	2.17 [55.0]
8 [200]	150	7.09 [180.0]	7.76 [197.0]	4.92 [125.0]	8	0.875 [22.00]	1.06 [27.0]	4 X M12x1.75	1.97 [50.0]	3.70 [94.0]	5.91 [150.0]	2.28 [58.0]
	300	8.21 [208.5]	8.66 [220.0]	4.92 [125.0]	12	1.000 [25.00]	1.57 [40.0]	4 X M16x2.00	2.20 [56.0]	4.13 [105.0]	6.89 [175.0]	2.36 [60.0]
10 [250]	150	8.78 [223.0]	9.33 [237.0]	5.08 [129.0]	12	1.000 [25.00]	1.14 [29.0]	4 X M12x1.75	2.36 [60.0]	4.25 [108.0]	5.91 [150.0]	2.36 [60.0]
	300	9.69 [246.0]	10.24 [260.0]	6.22 [158.0]	16	1.125 [29.00]	1.85 [47.0]	4 X M20x2.50	2.76 [70.0]	4.96 [126.0]	8.27 [210.0]	2.56 [65.0]
12 [300]	150	9.92 [252.0]	10.79 [274.0]	6.30 [160.0]	12	1.000 [25.00]	1.22 [31.0]	4 X M16x2.00	2.56 [65.0]	4.53 [115.0]	6.89 [175.0]	2.64 [67.0]
	300	11.10 [282.0]	11.81 [300.0]	7.40 [188.0]	16	1.250 [32.00]	1.97 [50.0]	4 X M20x2.5	2.95 [75.0]	4.72 [120.0]	8.27 [210.0]	2.76 [70.0]
14 [350]	150	11.26 [286.0]	12.99 [330.0]	8.19 [208.0]	12	1.125 [29.00]	1.38 [35.0]	4 X M20x2.5	3.15 [80.0]	5.43 [138.0]	8.27 [210.0]	3.07 [78.0]
	300	12.60 [320.0]	13.78 [350.0]	9.53 [242.0]	20	1.250 [32.00]	2.13 [54.0]	8 X M16x2.0	3.74 [95.0]	6.30 [160.0]	11.81 [300.0]	3.07 [78.0]
16 [400]	150	12.52 [318.0]	14.37 [365.0]	8.39 [213.0]	16	1.125 [29.00]	1.46 [37.0]	4 X M20x2.5	3.23 [82.0]	5.51 [140.0]	8.27 [210.0]	3.15 [80.0]
	300	13.94 [354.0]	15.35 [390.0]	11.18 [284.0]	20	1.375 [35.00]	2.28 [58.0]	8 X M20x2.5	3.94 [100.0]	6.50 [165.0]	13.78 [350.0]	3.35 [85.0]
18 [450]	150	13.78 [350.0]	15.55 [395.0]	9.13 [232.0]	16	1.250 [32.00]	1.57 [40.0]	8 X M16x2.0	3.54 [90.0]	5.91 [150.0]	11.81 [300.0]	3.27 [83.0]
	300	15.16 [385.0]	17.13 [435.0]	11.65 [296.0]	24	1.375 [35.00]	2.40 [61.0]	8 X M20x2.5	4.13 [105.0]	7.09 [180.0]	13.78 [350.0]	3.39 [86.0]
20 [500]	150	15.12 [384.0]	16.93 [430.0]	9.61 [244.0]	20	1.250 [32.00]	1.69 [43.0]	8 X M16x2.0	4.13 [105.0]	7.09 [180.0]	11.81 [300.0]	3.54 [90.0]
	300	17.05 [433.0]	18.70 [475.0]	12.99 [330.0]	24	1.375 [35.00]	2.52 [64.0]	8 X M30x3.5	7.48 [190.0]	5.51 [140.0]	16.34 [415.0]	3.46 [88.0]
24 [600]	150	17.48 [444.5]	19.29 [490.0]	11.61 [295.0]	20	1.375 [35.00]	1.89 [48.0]	8 X M20x2.5	7.48 [190.0]	5.12 [130.0]	13.78 [350.0]	3.35 [85.0]
	300	19.37 [492.0]	21.46 [545.0]	14.88 [378.0]	24	1.625 [42.00]	2.76 [70.0]	8 X M30x3.5	7.48 [190.0]	5.91 [150.0]	16.34 [415.0]	3.54 [90.0]

All the dimensions are in Inch [Metric]

Long Pattern Dimensions: 26 to 60 in per ASME B16.10 and API 609

ASME Class 150, 300, and 600

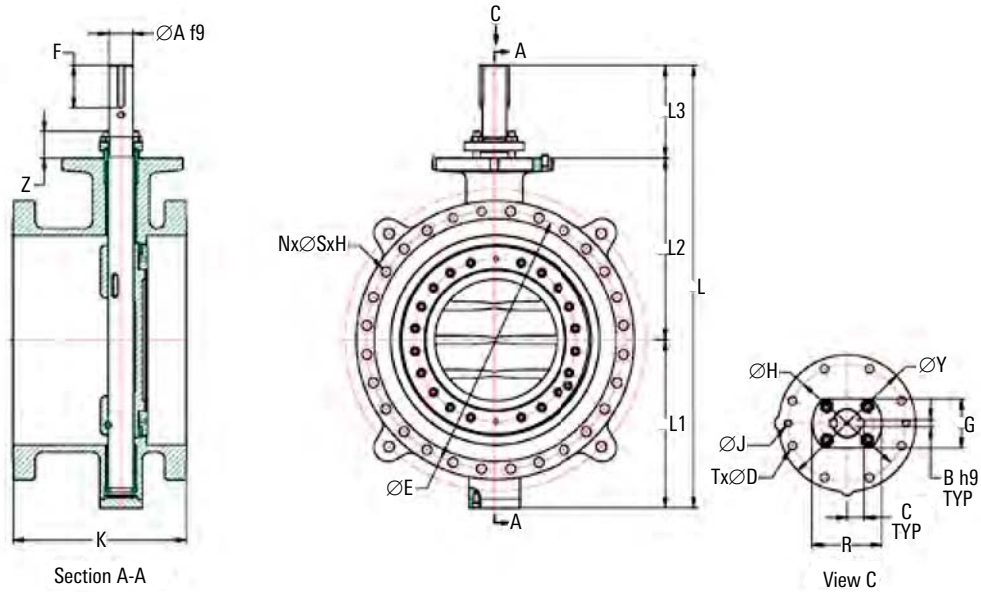

Long Pattern Dimensions: 26 to 60 in per ASME B16.10 and API 609

Size, in [mm]	Class	ØA f9	B h9	C +0.000/-0.006 [+0.00/-0.15]	Flange Type	ØY	T x ØD THRU HOLE	ØH	ØJ	R	G	L
26 [650]	150	3.1 [80.0]	0.8 [20.0]	1.9 [48.0]	F30	13.8 [350.0]	8 X M20	11.7 [298.0]	0.6 [15.5]	8.9 [225.0]	7.1 [180.0]	52.8 [1,340.0]
	300	3.9 [100.0]	0.9 [22.0]	2.3 [59.0]	F40	18.7 [475.0]	8 x M36	16.0 [406.0]	0.9 [22.0]	10.2 [260.0]	7.9 [200.0]	58.7 [1,490.0]
	600	5.3 [135.0]	1.3 [32.0]	3.2 [80.5]	F48	22.0 [560.0]	12 x M36	19.0 [483.0]	1.0 [25.0]	12.6 [320.0]	9.1 [230.0]	67.7 [1,720.0]
30 [750]	150	3.3 [85.0]	0.9 [22.0]	2.0 [51.5]	F35	16.3 [415.0]	8 x M30	14.0 [356.0]	0.9 [22.0]	8.3 [210.0]	5.9 [150.0]	61.5 [1,562.0]
	300	4.5 [115.0]	1.1 [28.0]	2.7 [68.5]	F40	18.7 [475.0]	8 x M36	16.0 [406.0]	0.9 [22.0]	11.4 [290.0]	8.7 [220.0]	67.2 [1,707.0]
	600	5.7 [145.0]	1.4 [36.0]	3.4 [86.5]	F48	22.0 [560.0]	12 x M36	19.0 [483.0]	1.0 [25.0]	13.0 [330.0]	9.3 [236.0]	72.6 [1,845.0]
32 [800]	150	3.5 [90.0]	0.9 [22.0]	2.1 [54.0]	F35	16.3 [415.0]	8 X M30	14.0 [356.0]	0.9 [22.0]	8.5 [215.0]	6.1 [156.0]	62.7 [1,593.0]
	300	5.1 [130.0]	1.1 [28.0]	3.0 [76.0]	F40	18.7 [475.0]	8 x M36	16.0 [406.0]	0.9 [22.0]	11.0 [280.0]	8.5 [215.0]	69.9 [1,775.0]
	600	6.9 [175.0]	1.4 [36.0]	4.0 [101.5]	F48	22.0 [560.0]	12 x M36	19.0 [483.0]	1.0 [25.0]	14.4 [365.0]	10.6 [270.0]	77.2 [1,960.0]
36 [900]	150	4.1 [105.0]	0.9 [22.0]	2.4 [61.5]	F35	16.3 [415.0]	8 x M30	14.0 [356.0]	0.9 [22.0]	10.0 [255.0]	7.9 [200.0]	67.5 [1,714.0]
	300	5.5 [140.0]	1.1 [28.0]	3.2 [81.0]	F48	22.0 [560.0]	12 x M36	19.0 [483.0]	1.0 [24.5]	12.8 [325.0]	9.1 [230.0]	75.6 [1,920.0]
	600	7.7 [195.0]	1.8 [45.0]	4.5 [114.5]	F60	27.0 [686.0]	20 x M36	23.7 [603.0]	1.2 [30.0]	15.7 [400.0]	11.2 [284.0]	84.8 [2,155.0]
40 [1,000]	150	4.5 [115.0]	1.1 [28.0]	2.7 [68.5]	F40	18.7 [475.0]	8 X M36	16.0 [406.0]	0.9 [22.0]	11.4 [290.0]	8.7 [220.0]	74.2 [1,885.0]
	300	6.3 [160.0]	1.4 [36.0]	3.7 [94.0]	F48	22.0 [560.0]	12 x M36	19.0 [483.0]	1.0 [25.0]	12.8 [325.0]	9.8 [250.0]	79.1 [2,010.0]
	600	8.5 [215.0]	1.8 [45.0]	4.9 [124.5]	F60	27.0 [686.0]	20 x M36	23.7 [603.0]	1.2 [30.0]	18.1 [460.0]	13.9 [352.0]	90.0 [2,285.0]
42 [1,050]	150	5.1 [130.0]	1.1 [28.0]	3.1 [78.5]	F40	18.7 [475.0]	8 x M36	16.0 [406.0]	0.9 [22.0]	11.0 [280.0]	8.5 [215.0]	78.3 [1,990.0]
	300	6.3 [160.0]	1.4 [36.0]	3.7 [94.0]	F48	22.0 [560.0]	12 x M36	19.0 [483.0]	1.0 [25.0]	12.8 [325.0]	9.8 [250.0]	82.4 [2,092.0]
	600	8.7 [220.0]	1.8 [45.0]	5.0 [127.0]	F60	27.0 [686.0]	20 x M36	23.7 [603.0]	1.2 [30.0]	18.1 [460.0]	13.4 [340.0]	93.9 [2,385.0]
46 [1,150]	150	5.5 [140.0]	1.1 [28.0]	3.2 [81.0]	F40	18.7 [475.0]	8 X M36	16.0 [406.0]	0.9 [22.0]	11.4 [290.0]	8.7 [220.0]	82.1 [2,085.0]
	300	6.7 [170.0]	1.1 [28.0]	3.8 [96.0]	F60	27.0 [686.0]	20 x M36	23.7 [603.0]	1.2 [30.0]	14.4 [365.0]	9.8 [250.0]	90.0 [2,285.0]
	600	9.3 [235.0]	1.8 [45.0]	5.3 [134.5]	F60	27.0 [686.0]	20 x M36	23.7 [603.0]	1.2 [30.0]	19.1 [485.0]	15.0 [380.0]	100.2 [2,546.0]

All the dimensions are in Inch [Metric]

Long Pattern Dimensions: 26 to 60 in per ASME B 16.10 and API 609

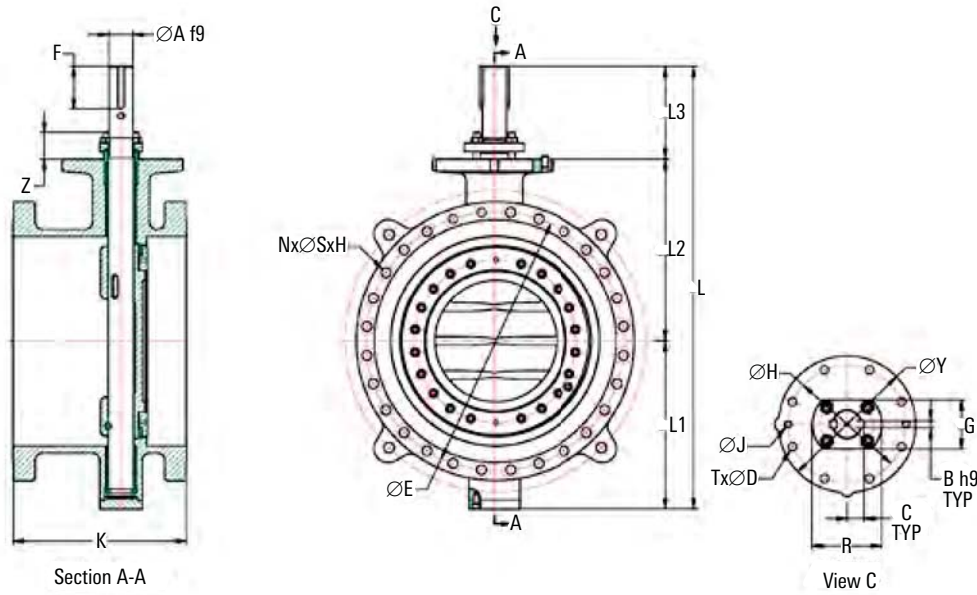

Long Pattern Dimensions: 26 to 60 in per ASME B16.10 and API 609

Size, in [mm]	Class	ØA f9	B h9	C +0.000/-0.006 [+0.00/-0.15]	Flange Type	ØY	T x ØD THRU HOLE	ØH	ØJ	R	G	L
48 [1,200]	150	5.9 [150.0]	1.4 [36.0]	3.5 [89.0]	F40	18.7 [475.0]	8 x M36	16.0 [406.0]	0.9 [22.0]	11.6 [295.0]	9.3 [236.0]	83.3 [2,115.0]
	300	6.7 [170.0]	1.1 [28.0]	3.8 [96.0]	F60	27.0 [686.0]	20 x M36	23.7 [603.0]	1.2 [30.0]	14.4 [365.0]	9.8 [250.0]	90.6 [2,300.0]
	600	9.3 [235.0]	1.8 [45.0]	5.3 [134.5]	F60	27.0 [686.0]	20 x M36	23.7 [603.0]	1.2 [30.0]	19.1 [485.0]	15.0 [380.0]	101.8 [2,586.0]
52 [1,300]	150	6.5 [165.0]	1.4 [36.0]	3.8 [96.5]	F48	22.0 [560.0]	12 X M36	19.0 [483.0]	1.0 [25.0]	13.2 [335.0]	10.2 [260.0]	90.9 [2,310.0]
	300	8.1 [205.0]	1.8 [45.0]	4.7 [119.5]	F60	27.0 [686.0]	20 x M36	23.7 [603.0]	1.2 [30.0]	16.9 [430.0]	13.0 [330.0]	98.8 [2,510.0]
	600	11.6 [295.0]	2.5 [63.0]	6.9 [174.5]	F80	35.4 [900.0]	20 x M42	32.0 [813.0]	1.4 [35.0]	21.7 [550.0]	15.7 [400.0]	114.2 [2,900.0]
54 [1,350]	150	6.7 [170.0]	1.4 [36.0]	3.9 [99.0]	F48	22.0 [560.0]	12 X M36	19.0 [483.0]	1.0 [25.0]	14.4 [365.0]	9.8 [250.0]	93.9 [2,385.0]
	300	8.5 [215.0]	1.8 [45.0]	4.9 [124.5]	F60	27.0 [686.0]	20 x M36	23.7 [603.0]	1.2 [30.0]	18.1 [460.0]	13.9 [352.0]	101.2 [2,570.0]
	600	12.6 [320.0]	2.5 [63.0]	7.4 [187.0]	F80	35.4 [900.0]	20 x M42	32.0 [813.0]	1.4 [35.0]	22.4 [570.0]	—	119.2 [3,028.0]
56 [1,400]	150	7.1 [180.0]	1.4 [36.0]	4.1 [104.0]	F48	22.0 [560.0]	12 X M36	19.0 [483.0]	1.0 [25.0]	14.4 [365.0]	11.0 [280.0]	97.6 [2,480.0]
	300	8.9 [225.0]	1.8 [45.0]	5.1 [129.5]	F60	27.0 [686.0]	20 x M36	23.7 [603.0]	1.2 [30.0]	16.1 [410.0]	11.4 [290.0]	107.1 [2,720.0]
	600	13.2 [335.0]	2.8 [70.0]	7.8 [197.5]	F80	35.4 [900.0]	20 x M42	32.0 [813.0]	1.4 [35.0]	23.2 [590.0]	—	126.4 [3,210.0]
58 [1,450]	150	7.5 [190.0]	1.6 [40.0]	4.3 [110.0]	F48	22.0 [560.0]	12 X M36	19.0 [483.0]	1.0 [25.0]	14.4 [365.0]	11.4 [290.0]	103.0 [2,615.0]
	300	9.4 [240.0]	1.8 [45.0]	5.4 [137.0]	F60	27.0 [686.0]	20 x M36	23.7 [603.0]	1.2 [30.0]	18.7 [475.0]	14.2 [360.0]	110.6 [2,810.0]
	600	13.6 [345.0]	2.8 [70.0]	8.0 [202.5]	F80	35.4 [900.0]	20 x M42	32.0 [813.0]	1.4 [35.0]	25.2 [640.0]	—	129.6 [3,293.0]
60 [1,500]	150	8.5 [215.0]	1.8 [45.0]	4.9 [124.5]	F48	22.0 [560.0]	12 X M36	19.0 [483.0]	1.0 [25.0]	15.2 [385.0]	12.2 [310.0]	103.7 [2,635.0]
	300	10.0 [255.0]	2.0 [50.0]	5.8 [146.5]	F60	27.0 [686.0]	20 x M36	23.7 [603.0]	1.2 [30.0]	18.7 [475.0]	14.8 [375.0]	115.6 [2,935.0]
	600	14.0 [355.0]	2.8 [70.0]	8.2 [207.5]	F80	35.4 [900.0]	20 x M42	32.0 [813.0]	1.4 [35.0]	24.4 [620.0]	—	134.1 [3,405.0]

All the dimensions are in Inch [Metric]

Long Pattern Dimensions: 26 to 60 in per ASME B16.10 and API 609

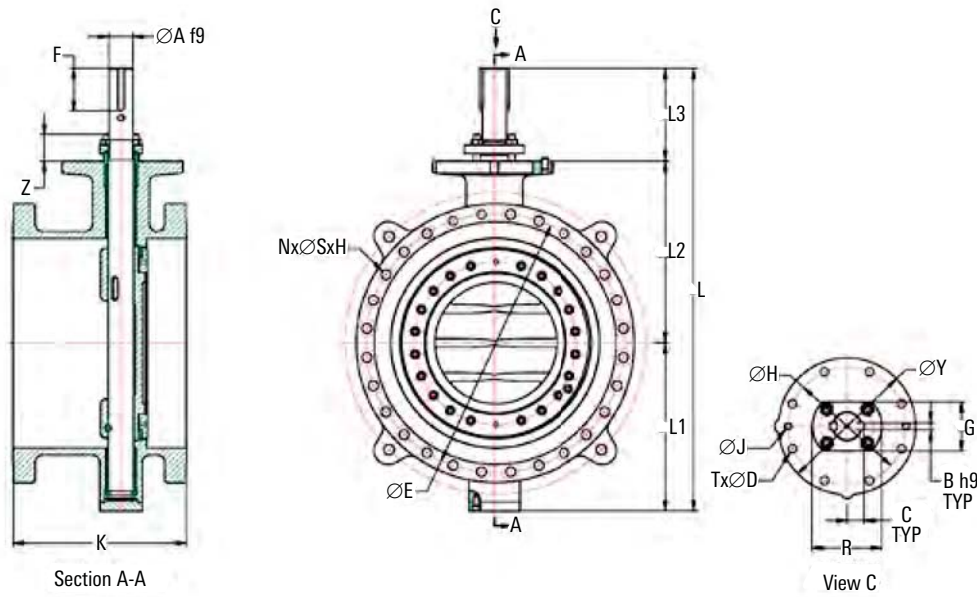

Long Pattern Dimensions: 26 to 60 in per ASME B16.10 and API 609

Size, in [mm]	Class	L1	L2	L3	ØE	N (No's)	ØS	H	K	F	Z
26 [650]	150	19.8 [502.0]	21.7 [550.0]	11.3 [288.0]	31.7 [806.4]	24	1.4 [35.0]	2.8 [71.0]	22.0 [559.0]	5.9 [150.0]	3.7 [95.0]
	300	21.6 [548.0]	23.6 [600.0]	13.5 [342.0]	34.5 [876.3]	28	1.8 [44.5]	3.2 [82.0]	49.0 [1,245.0]	6.0 [152.0]	4.1 [105.0]
	600	25.8 [655.0]	25.4 [645.0]	16.5 [420.0]	36.0 [914.4]	28	2.0 [51.0]	4.4 [111.0]	57.0 [1,448.0]	7.9 [200.0]	5.1 [130.0]
30 [750]	150	23.3 [592.0]	25.3 [642.0]	12.9 [328.0]	36.0 [914.4]	28	1.4 [35.0]	3.0 [77.0]	24.0 [610.0]	5.9 [150.0]	3.7 [94.0]
	300	25.0 [636.0]	26.5 [674.0]	15.6 [397.0]	39.3 [997.0]	28	1.9 [48.0]	3.7 [94.0]	55.0 [1,397.0]	8.1 [207.0]	4.5 [115.0]
	600	28.3 [720.0]	27.8 [705.0]	16.5 [420.0]	40.3 [1022.4]	28	2.1 [54.0]	4.6 [118.0]	65.0 [1,651.0]	7.9 [200.0]	4.9 [125.0]
32 [800]	150	23.9 [608.0]	26.0 [660.0]	12.8 [325.0]	38.5 [977.9]	28	1.7 [42.0]	3.3 [83.0]	26.0 [660.0]	5.9 [150.0]	3.9 [100.0]
	300	26.1 [663.0]	27.6 [700.0]	16.2 [412.0]	41.5 [1,054.1]	28	2.0 [51.0]	4.0 [101.0]	60.0 [1,524.0]	8.7 [222.0]	4.7 [120.0]
	600	30.1 [765.0]	30.5 [775.0]	16.5 [420.0]	42.5 [1,079.5]	28	2.4 [61.0]	4.8 [121.0]	70.0 [1,778.0]	7.9 [200.0]	5.9 [150.0]
36 [900]	150	26.1 [664.0]	27.2 [690.0]	14.2 [360.0]	42.7 [1,085.8]	32	1.7 [42.0]	3.7 [93.0]	28.0 [711.0]	7.3 [185.0]	3.5 [90.0]
	300	29.1 [738.0]	29.7 [755.0]	16.8 [427.0]	46.0 [1,168.4]	32	2.1 [54.0]	4.2 [107.0]	68.0 [1,727.0]	8.1 [207.0]	4.7 [120.0]
	600	32.7 [831.0]	32.5 [825.0]	19.6 [499.0]	47.0 [1,193.8]	28	2.6 [67.0]	5.0 [127.0]	82.0 [2,083.0]	10.6 [270.0]	6.7 [170.0]
40 [1,000]	150	28.1 [713.0]	29.9 [760.0]	16.2 [412.0]	47.3 [1,200.2]	36	1.6 [41.5]	3.7 [93.0]	30.0 [762.0]	8.7 [220.0]	4.7 [120.0]
	300	30.1 [765.0]	32.5 [825.0]	16.5 [420.0]	45.5 [1,155.7]	32	1.8 [44.5]	4.6 [117.0]	76.0 [1,930.0]	7.9 [200.0]	4.9 [125.0]
	600	33.7 [855.0]	36.8 [935.0]	19.5 [495.0]	47.7 [1,212.8]	32	2.4 [61.0]	6.4 [162.0]	90.0 [2,286.0]	10.6 [270.0]	6.5 [165.0]
42 [1,050]	150	30.9 [785.0]	31.5 [800.0]	15.9 [405.0]	49.5 [1,257.3]	36	1.6 [41.5]	3.9 [99.0]	32.0 [812.0]	8.7 [220.0]	5.3 [135.0]
	300	31.7 [805.0]	34.6 [880.0]	16.0 [407.0]	47.5 [1,206.5]	32	1.8 [44.5]	4.8 [121.0]	76.0 [1,930.0]	7.4 [187.0]	5.1 [130.0]
	600	35.8 [910.0]	38.4 [975.0]	19.7 [500.0]	50.5 [1,282.7]	28	2.6 [67.0]	6.8 [172.0]	96.0 [2,438.0]	10.6 [270.0]	6.7 [170.0]
46 [1,150]	150	31.9 [810.0]	33.9 [860.0]	16.3 [415.0]	53.7 [1,365.2]	40	1.6 [41.5]	4.2 [106.0]	33.5 [850.0]	8.7 [220.0]	5.3 [135.0]
	300	32.9 [835.0]	37.4 [950.0]	19.7 [500.0]	52.0 [1,320.8]	28	2.0 [51.0]	5.2 [131.0]	88.0 [2,235.0]	10.2 [260.0]	5.1 [130.0]
	600	37.8 [960.0]	41.3 [1,050.0]	21.1 [536.0]	54.7 [1,390.6]	32	2.6 [67.0]	7.3 [185.0]	100.0 [2,540.0]	10.6 [270.0]	6.5 [165.0]

All the dimensions are in Inch [Metric]

Long Pattern Dimensions: 26 to 60 in per ASME B 16.10 and API 609

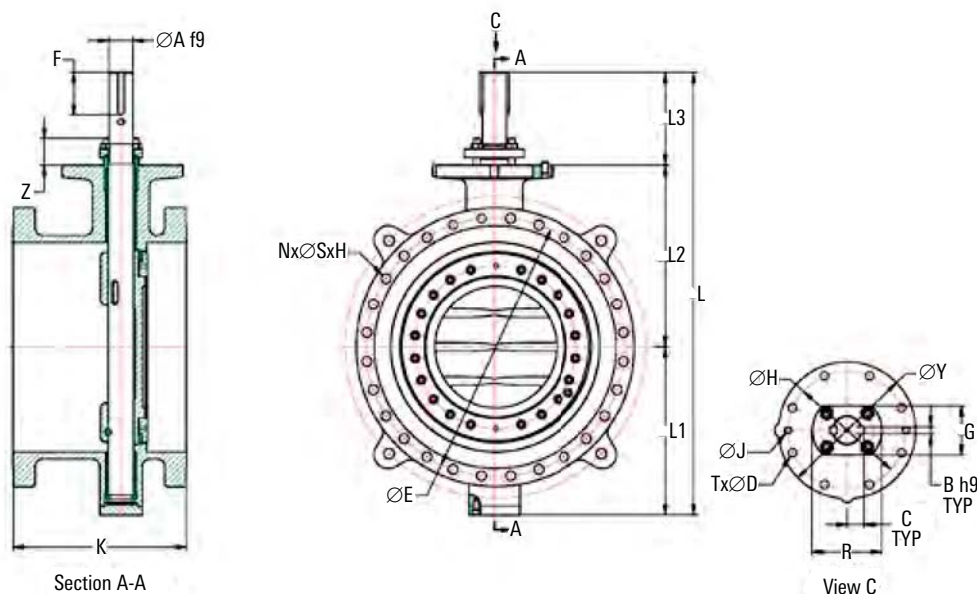

Long Pattern Dimensions: 26 to 60 in per ASME B16.10 and API 609

Size, in [mm]	Class	L1	L2	L3	ØE	N (No's)	ØS	H	K	F	Z
48 [1,200]	150	32.3 [820.0]	35.6 [905.0]	15.4 [390.0]	56.0 [1,422.4]	44	1.6 [41.5]	4.3 [110.0]	34.0 [864.0]	7.9 [200.0]	5.3 [135.0]
	300	32.9 [835.0]	38.0 [965.0]	19.7 [500.0]	54.0 [1,371.6]	32	2.0 [51.0]	5.4 [136.0]	88.0 [2,235.0]	10.2 [260.0]	5.1 [130.0]
	600	39.0 [990.0]	42.7 [1,085.0]	20.1 [511.0]	57.5 [1,460.5]	32	2.9 [73.0]	7.6 [192.0]	100.0 [2,540.0]	10.6 [270.0]	6.5 [165.0]
52 [1,300]	150	36.2 [920.0]	38.2 [970.0]	16.5 [420.0]	60.5 [1,536.7]	44	1.9 [48.0]	4.6 [118.0]		7.9 [200.0]	5.1 [130.0]
	300	38.2 [970.0]	41.3 [1,050.0]	19.3 [490.0]	58.3 [1,479.6]	32	2.1 [54.0]	5.7 [146.0]		9.8 [250.0]	6.1 [155.0]
	600	43.1 [1,094.0]	47.0 [1,195.0]	24.1 [611.0]	62.0 [1,574.8]	32	3.1 [80.0]	8.1 [207.0]		13.8 [350.0]	8.5 [215.0]
54 [1,350]	150	37.6 [955.0]	39.8 [1,010.0]	16.5 [420.0]	62.7 [1,593.8]	44	1.9 [48.0]	4.8 [123.0]		7.9 [200.0]	5.1 [130.0]
	300	39.4 [1,000.0]	43.3 [1,100.0]	18.5 [470.0]	61.0 [1,549.4]	28	2.4 [60.5]	6.1 [154.0]		9.1 [230.0]	6.5 [165.0]
	600	46.5 [1,182.0]	48.2 [1,225.0]	24.4 [621.0]	64.3 [1,632.0]	32	3.1 [80.0]	8.4 [213.0]		14.2 [360.0]	8.7 [220.0]
56 [1,400]	150	38.6 [980.0]	40.2 [1,020.0]	18.9 [480.0]	65.0 [1,651.0]	48	1.9 [48.0]	5.0 [126.0]		10.2 [260.0]	6.1 [155.0]
	300	40.7 [1,035.0]	45.3 [1,150.0]	21.1 [535.0]	63.0 [1,600.2]	28	2.4 [60.5]	6.1 [156.0]	Upon Request	11.8 [300.0]	6.3 [160.0]
	600	48.2 [1,224.0]	50.8 [1,290.0]	27.4 [696.0]	66.7 [1,695.4]	32	3.4 [86.0]	8.7 [221.0]		14.8 [375.0]	8.7 [220.0]
58 [1,450]	150	39.2 [995.0]	42.3 [1,075.0]	21.5 [545.0]	67.3 [1,708.2]	48	1.9 [48.0]	5.1 [130.0]		12.8 [325.0]	6.1 [155.0]
	300	42.1 [1,070.0]	46.3 [1,175.0]	22.2 [565.0]	65.0 [1,651.0]	32	2.4 [60.5]	6.3 [161.0]		12.8 [325.0]	6.5 [165.0]
	600	49.3 [1,253.0]	52.4 [1,330.0]	28.0 [710.0]	68.7 [1,746.2]	32	3.4 [86.0]	8.9 [226.0]		15.7 [400.0]	8.9 [225.0]
60 [1,500]	150	41.1 [1,045.0]	44.1 [1,120.0]	18.5 [470.0]	69.3 [1,759.0]	52	1.9 [48.0]	5.3 [134.0]		9.8 [250.0]	6.3 [160.0]
	300	45.2 [1,149.0]	48.0 [1,220.0]	22.3 [566.0]	67.0 [1,701.8]	32	2.4 [60.0]	6.7 [170.0]		12.8 [325.0]	7.3 [185.0]
	600	52.3 [1,329.0]	53.7 [1,365.0]	28.0 [711.0]	71.7 [1,822.4]	28	3.6 [92.0]	9.7 [247.0]		15.7 [400.0]	9.6 [245.0]

All the dimensions are in Inch [Metric]

Gear Operator Dimensions

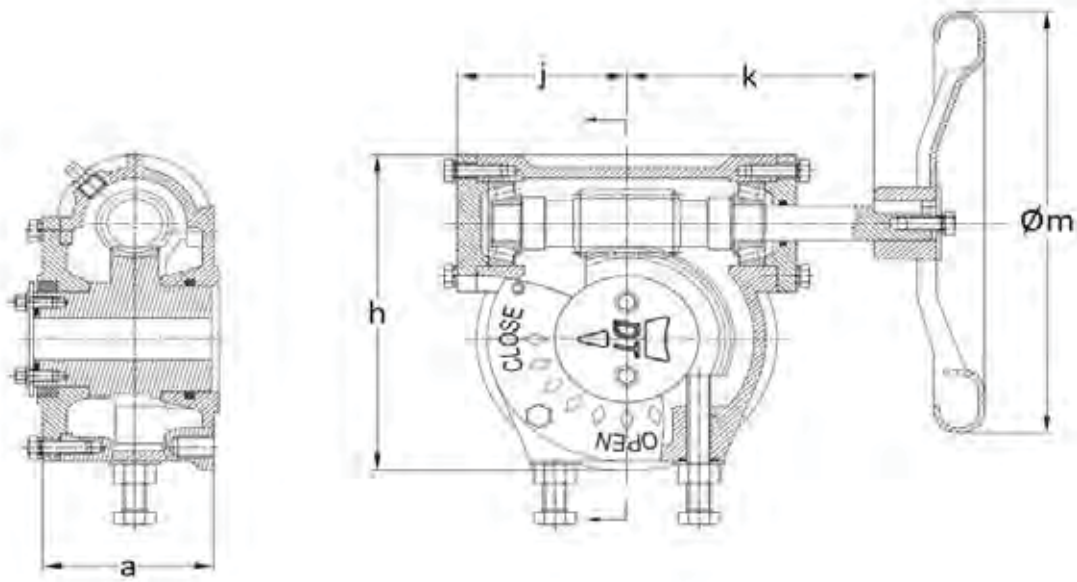

Gear Dimensions

Valve Size, in [mm]	ASME Class	Model	a	h	k	j	Øm
3 [80]	150	GB-BF	1.81 [46]	4.45 [113]	2.09 [53]	3.58 [91]	6 [152]
	300	GB-BF	1.81 [46]	4.45 [113]	2.09 [53]	3.58 [91]	8 [203]
4 [100]	150	GB-BF	1.81 [46]	4.45 [113]	2.09 [53]	3.58 [91]	6 [152]
	300	GB-00	2.87 [73]	5.91 [150]	2.80 [71]	4.06 [103]	12 [305]
	600	GB-01-1S	3.66 [93]	8.86 [225]	3.66 [93]	6.73 [171]	14 [350]
6 [150]	150	GB-00	2.87 [73]	5.91 [150]	2.80 [71]	4.06 [103]	10 [254]
	300	GB-01	3.82 [97]	7.99 [203]	3.66 [93]	5.71 [145]	20 [508]
	600	GB-02-1S	4.33 [110]	11.26 [286]	4.45 [113]	8.07 [205]	18 [450]
8 [200]	150	GB-0	3.70 [94]	7.13 [181]	3.27 [83]	5.28 [134]	16 [406]
	300	GB-02	4.49 [114]	9.65 [245]	4.45 [113]	7.64 [194]	34 [864]
	600	GB-04-1SD	4.88 [124]	15.31 [389]	6.22 [158]	11.30 [287]	26 [650]
10 [250]	150	GB-01	3.82 [97]	7.99 [203]	3.66 [93]	5.71 [145]	24 [610]
	300	GB-03-1S	4.50 [115]	12.80 [325]	4.92 [125]	8.54 [217]	22 [559]
	600	B38	5.79 [147]	16.69 [424]	6.26 [159]	10.91 [277]	28 [700]
12 [300]	150	GB-02	4.49 [114]	9.65 [245]	4.45 [113]	7.64 [194]	28 [711]
	300	GB-04-1S	5.04 [128]	15.08 [383]	6.22 [158]	9.69 [246]	34 [864]
	600	B48	6.50 [165]	21.42 [544]	8.39 [213]	15.04 [382]	28 [700]
14 [350]	150	GB-02-1S	4.49 [114]	11.26 [286]	4.45 [113]	8.07 [205]	24 [610]
	300	B38	5.91 [150]	16.69 [424]	6.26 [159]	10.71 [272]	30 [762]
	600	B48	6.50 [165]	21.42 [544]	8.39 [213]	15.04 [382]	33 [850]
16 [400]	150	GB-03-1S	4.50 [115]	12.80 [325]	4.92 [125]	8.54 [217]	26 [660]
	300	B48	6.69 [170]	21.42 [544]	8.39 [213]	14.84 [377]	24 [610]
	600	B58	7.91 [201]	26.18 [665]	10.98 [279]	17.91 [455]	30 [750]
18 [450]	150	GB-04-1S	5.04 [128]	15.08 [383]	6.22 [158]	9.69 [246]	34 [864]
	300	B48	6.69 [170]	21.42 [544]	8.39 [213]	14.84 [377]	32 [813]
	600	B58+1S02	7.91 [201]	26.18 [665]	10.98 [279]	21.14 [537]	30 [750]
20 [500]	150	B38	5.91 [150]	16.69 [424]	6.26 [159]	10.71 [272]	26 [660]
	300	B48	6.69 [170]	21.42 [544]	8.39 [213]	14.84 [377]	40 [1,016]
	600	GB-09-1SD+1S02	9.21 [234]	30.43 [773]	13.19 [335]	23.31 [592]	24 [600]
24 [600]	150	B48	6.69 [170]	21.42 [544]	8.39 [213]	14.84 [377]	22 [559]
	300	B58	8.07 [205]	26.18 [665]	10.98 [279]	17.52 [445]	36 [914]
	600	GB-09-1SD+1S02	9.21 [234]	30.43 [773]	13.19 [335]	23.31 [592]	35 [900]

All the dimensions are in Inch [Metric]

Valve Size, in [mm]	ASME Class	Model	a	h	j	k	Øm
26 [650]	150	B48	6.50 [165]	21.42 [544]	8.39 [213]	16.22 [412]	28 [700]
30 [750]	150	B48	6.50 [165]	21.42 [544]	8.39 [213]	16.22 [412]	28 [700]
32 [800]	150	GB-07-2SD	7.48 [190]	22.95 [583]	9.33 [237]	15.79 [401]	30 [750]
36 [900]	150	B58	7.91 [201]	26.18 [665]	10.98 [279]	17.52 [445]	31 [800]
40 [1000]	150	GB-08-1SD+1S04	7.91 [201]	26.38 [670]	10.98 [279]	21.10 [536]	31 [800]
42 [1050]	150	GB-09-1SD+1S04	9.13 [232]	30.59 [777]	13.43 [341]	23.90 [607]	31 [800]
46 [1150]	150	GB-09-1SD+1S04	9.13 [232]	30.59 [777]	13.43 [341]	23.90 [607]	31 [800]
48 [1200]	150	GB-09-1SD+1S04	9.13 [232]	30.59 [777]	13.43 [341]	23.90 [607]	31 [800]
52 [1300]	150	GB-09-1SD+1S04	9.13 [232]	30.59 [777]	13.43 [341]	23.90 [607]	31 [800]
54 [1350]	150	KB-10-1SD+1S05	11.10 [282]	37.70 [958]	15.24 [387]	28.94 [735]	31 [800]
56 [1400]	150	KB-10-1SD+1S05	11.10 [282]	37.70 [958]	15.24 [387]	28.94 [735]	31 [800]
58 [1450]	150	KB-10-1SD+1S05	11.10 [282]	37.70 [958]	15.24 [387]	28.94 [735]	31 [800]
60 [1500]	150	KB-10-1SD+1S05	11.10 [282]	37.70 [958]	15.24 [387]	28.94 [735]	31 [800]

Valve Size, in [mm]	ASME Class	Model	a	h	j	k	ØM
26 [650]	300	GB-08-1SD+1S04	7.91 [201]	26.38 [670]	10.98 [279]	21.10 [536]	31 [800]
30 [750]	300	GB-09-1SD+1S04	9.13 [232]	30.59 [777]	13.43 [341]	23.90 [607]	31 [800]
32 [800]	300	GB-09-1SD+1S04	9.13 [232]	30.59 [777]	13.43 [341]	23.90 [607]	31 [800]
36 [900]	300	KB-10-1SD+1S05	11.10 [282]	37.70 [958]	15.24 [387]	28.94 [735]	31 [800]
40 [1,000]	300	KB-10-1SD+1S05	11.10 [282]	37.70 [958]	15.24 [387]	28.94 [735]	31 [800]
42 [1,050]	300	KB-10-1SD+1S05	11.10 [282]	37.70 [958]	15.24 [387]	28.94 [735]	31 [800]
46 [1,150]	300	KB-11-1SD+V8	13.31 [338]	43.70 [1,110]	18.39 [467]	37.05 [941]	33 [850]
48 [1,200]	300	KB-11-1SD+V8	13.31 [338]	43.70 [1,110]	18.39 [467]	37.05 [941]	33 [850]
52 [1,300]	300	KB-11-1SD+V8	13.31 [338]	43.70 [1,110]	18.39 [467]	37.05 [941]	33 [850]
54 [1,350]	300						
56 [1,400]	300						
58 [1,450]	300						
60 [1,500]	300						

Upon request

Valve Size, in [mm]	ASME Class	Model	A	H	J	K	ØM
26 [650]	600	GB-09-1SD+1S04	9.13 [232]	30.59 [777]	13.43 [341]	23.90 [607]	31 [800]
30 [750]	600	KB-10-1SD+1S05	11.10 [282]	37.70 [958]	15.24 [387]	28.94 [735]	31 [800]
32 [800]	600	KB-10-1SD+1S05	11.10 [282]	37.70 [958]	15.24 [387]	28.94 [735]	31 [800]
36 [900]	600	KB-11-1SD+V8	13.31 [338]	43.70 [1,110]	18.39 [467]	37.05 [941]	33 [850]
40 [1,000]	600	KB-11-1SD+V8	13.31 [338]	43.70 [1,110]	18.39 [467]	37.05 [941]	33 [850]
42 [1,050]	600						
46 [1,150]	600						
48 [1,200]	600						
52 [1,300]	600						
54 [1,350]	600						
56 [1,400]	600						
58 [1,450]	600						
60 [1,500]	600						

Upon request

All the dimensions are in Inch [Metric]

Pressure and Temperature Ratings (ASME B16.34)[†]

Temperature, degF [degC]	ASME 150		ASME 300		ASME 600	
	Carbon Steel	Stainless Steel [‡]	Carbon Steel	Stainless Steel [‡]	Carbon Steel	Stainless Steel [‡]
-20 to 100 [-29 to 38]	285	275	740	720	1,480	1,440
200 [93]	260	240	675	620	1,350	1,240
300 [149]	230	215	655	560	1,315	1,120
400 [204]	200	195	635	515	1,270	1,030
500 [260]	170	170	600	480	1,200	955
600 [316]	140	140	550	450	1,095	905
650 [343]	125	125	535	445	1,075	890
700 [371]	110	110	535	430	1,065	865
750 [399]	95	95	505	425	1,010	845
800 [‡] [427]	80	80	410	415	825	830
850 [454]	65	65	270	405	535	810
900 [482]	50	50	170	395	345	790
950 [510]	35	35	105	385	205	775
1,000 [538]	20	20 [§]	50	365	105	725
1,100 [593]	—	20 [§]	—	305	—	610
1,150 [621]	—	20 [§]	—	235	—	472
1,200 [649]	—	20 [§]	—	185	—	370
1,250 [677]	—	20 [§]	—	145	—	295
1,300 [704]	—	20 [§]	—	115	—	235
1,350 [732]	—	20 [§]	—	95	—	190
1,400 [760]	—	20 [§]	—	75	—	150
1,450 [788]	—	20 [§]	—	60	—	115
1,500 [816]	—	15 [§]	—	40	—	85

Low-temperature gas test per API 598 for services below -20 degF [-29 degC] (316SS and PTFE seals)

[‡]WCB permissible, but not recommended for prolonged use above 800 degF [427 degC]

[‡]Above 800 degF [427 degC] stainless steel body valves, stem material to be determined

[§] Flanged-end valve ratings terminate at 1,000 degF [538 degC] for ASME Class 150

Weights

Weight, lbm [kg]—Valve Only—Bare Stem and Bracket

Size, in [mm]	Lug Pattern			ISO Short Pattern			Long Pattern	
	ASME Class			ASME Class			ASME Class	
	150	300	600	150	300	600	150	300
3 [80]	20 [9]	27 [11]	—	34 [16]	46 [21]	—	37 [17]	53 [24]
4 [100]	30 [14]	34 [16]	61 [28]	47 [22]	67 [31]	129 [59]	51 [23]	80 [36]
6 [150]	48 [22]	67 [30]	126 [57]	79 [36]	123 [56]	233 [106]	82 [37]	153 [70]
8 [200]	78 [36]	112 [51]	213 [96]	124 [56]	182 [83]	373 [169]	131 [60]	223 [101]
10 [250]	127 [58]	184 [84]	393 [178]	184 [84]	281 [128]	591 [268]	198 [90]	350 [159]
12 [300]	199 [91]	270 [123]	573 [260]	270 [123]	392 [178]	787 [357]	294 [133]	497 [226]
14 [350]	271 [123]	482 [219]	712 [323]	373 [169]	591 [269]	988 [448]	392 [178]	813 [369]
16 [400]	367 [167]	690 [313]	1,068 [484]	477 [217]	816 [370]	1,414 [641]	528 [240]	1,116 [506]
18 [450]	522 [237]	870 [395]	1,388 [630]	646 [293]	1,020 [463]	1,797 [815]	680 [309]	1,402 [636]
20 [500]	699 [317]	1,127 [512]	1,817 [824]	819 [372]	1,310 [595]	2,329 [1,057]	892 [405]	1,871 [849]
24 [600]	1,060 [481]	1,670 [758]	2,457 [1,114]	1,211 [550]	1,906 [865]	3,194 [1,449]	1,317 [598]	2,781 [1,262]

Weight, lbm [kg]—Valve Only—Bare Stem and Bracket

Size in [mm]	ASME Class 150		
	Lug Pattern	ISO Short Pattern	Long Pattern
26 [650]	1,294 [587]	1,598 [725]	1,779 [807]
30 [750]	1,731 [785]	2,339 [1,061]	2,497 [1,133]
32 [800]	2,234 [1,013]	2,584 [1,172]	2,931 [1,329]
36 [900]	2,762 [1,253]	3,368 [1,528]	3,922 [1,779]
40 [1,000]	3,657 [1,659]	4,589 [2,082]	4,991 [2,264]
42 [1,050]	4,308 [1,954]	5,318 [2,412]	5,852 [2,655]
46 [1,150]	5,214 [2,365]	6,623 [3,004]	7,249 [3,288]
48 [1,200]	5,917 [2,684]	7,301 [3,312]	8,090 [3,670]
52 [1,300]	—	9,637 [4,372]	Upon request
54 [1,350]	—	10,622 [4,818]	
56 [1,400]	—	11,994 [5,440]	
58 [1,450]	—	13,527 [6,136]	
60 [1,500]	—	14,162 [6,424]	

Weight, lbm [kg]—Valve Only—Bare Stem and Bracket

Size in [mm]	ASME Class - 300		
	Lug Pattern	ISO Short Pattern	Long Pattern
26 [650]	2,160 [980]	2,528 [1,147]	3,619 [1,641]
30 [750]	2,898 [1,315]	3,431 [1,556]	5,047 [2,289]
32 [800]	3,327 [1,509]	3,903 [1,770]	9,862 [4,474]
36 [900]	4,372 [1,983]	5,177 [2,348]	8,356 [3,790]
40 [1,000]	4,896 [2,221]	5,725 [2,597]	9,475 [4,298]
42 [1,050]	5,312 [2,409]	6,214 [2,819]	10,117 [4,589]
46 [1,150]	7,110 [3,225]	8,256 [3,745]	13,845 [6,280]
48 [1,200]	7,238 [3,283]	8,480 [3,846]	14,687 [6,662]
52 [1,300]	—	11,701 [5,307]	Upon request
54 [1,350]	—	13,061 [5,925]	
56 [1,400]	—	14,385 [6,525]	
58 [1,450]	—	16,316 [7,401]	
60 [1,500]	—	18,264 [8,285]	

Weight, lbm [kg]—Valve Only—Bare Stem and Bracket

Size in [mm]	ASME Class - 600		
	Lug Pattern	ISO Short Pattern	Long Pattern
26 [650]	3,400 [1,542]	4,156 [1,885]	5,936 [2,692]
30 [750]	4,406 [1,999]	5,264 [2,388]	8,212 [3,725]
32 [800]	5,287 [2,398]	6,294 [2,855]	98,62 [4,474]
36 [900]	6,700 [3,039]	8,180 [3,710]	13,483 [6,116]
40 [1,000]	8,200 [3,719]	9,731 [4,414]	16,634 [7,545]
42 [1,050]	9,351 [4,242]	11,059 [5,016]	19,649 [8,913]
46 [1,150]	11,449 [5,193]	13,584 [6,162]	23,799 [10,795]
48 [1,200]	12,395 [5,622]	14,900 [6,759]	27,071 [12,279]
52 [1,300]	—	19,989 [9,067]	Upon request
54 [1,350]	—	23,198 [10,522]	
56 [1,400]	—	25,594 [11,609]	
58 [1,450]	—	29,337 [13,307]	
60 [1,500]	—	32,279 [14,642]	

How to Order

Figure number

The figure number shown below identifies specific valve configuration details of TOVs, such as valve type, pressure class, end connections, body and bonnet and trim materials, and special features.

Please specify end connections, body materials, and trims not listed below.

When placing an order, refer to the respective product section of the catalog for size availability. A detailed description must be included with any special orders.

Additional details for nonstandard materials must be specified in the order.



91F-CBN-NC-FS-WGO

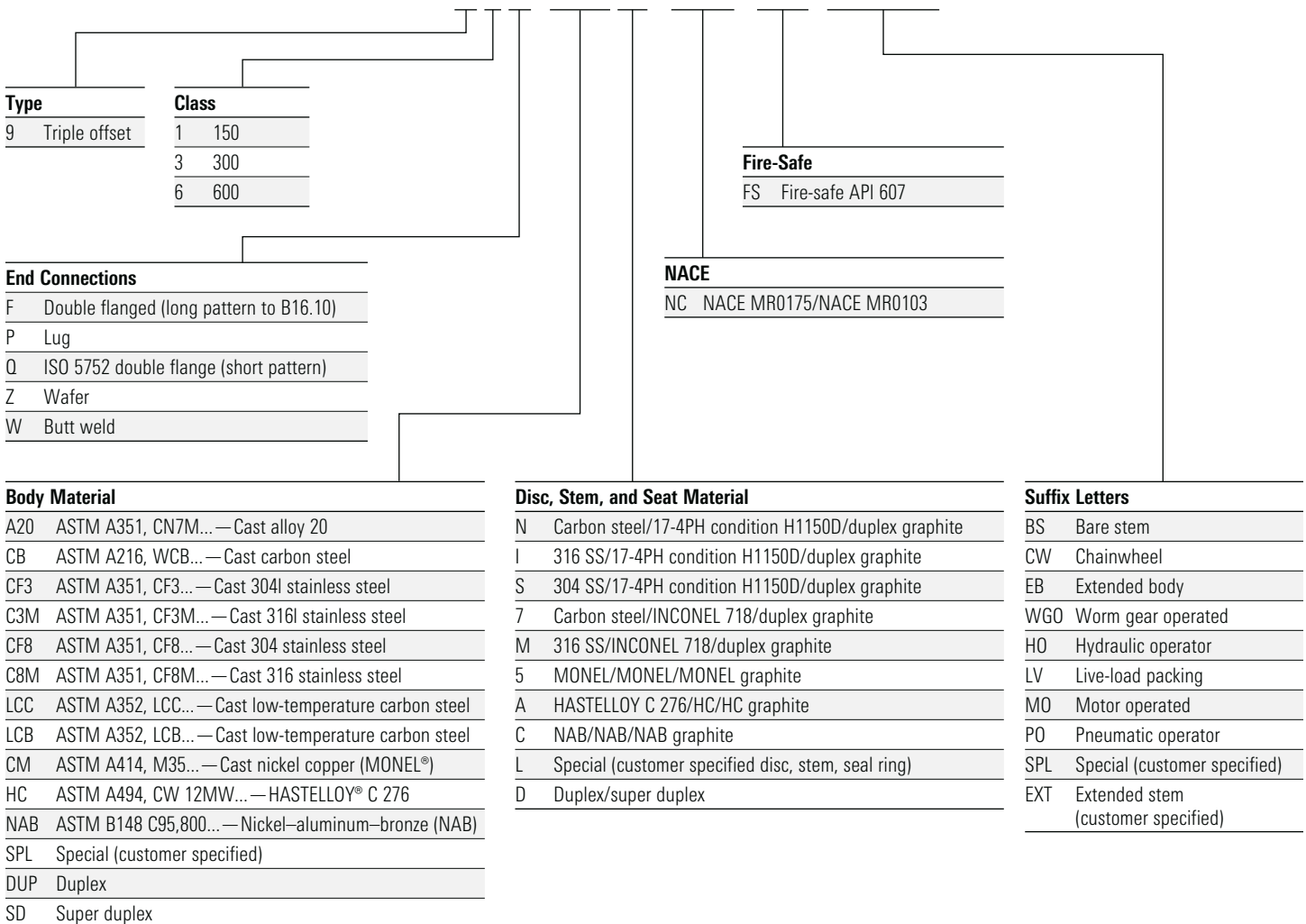

Distributed by | Distribuido por :



ANYTHINGTM
≈ FLOWS ≈

INFO@ANYTHINGFLOWS.COM

WWW.ANYTHINGFLOWS.COM

Flow Control , our passion ®

Life Flows on TM



SCAN ME