

MM & BPM Series

Direct-operated, spring pressure regulators



Suitable for:



Air & process gases



Liquids



Steam

Markets:



Oil & gas



Blanketing systems



General industry



Power

Valve ID card

Function
Reducing - Relief / Backpressure

Seat type
Single/Double

Inlet / Outlet diameters
From 1" up to 10" (standard ISA constructions)
Up to 20" (special constructions)

Body material
Carbon steel, Stainless steel and Exotic materials

End connections
Flanged (ANSI or NP)

Max rating
ANSI 1500

CV
From 6 to 850

Trim materials
Stainless steel (std) and Exotic materials

Diaphragms
Polychloroprene, EPDM, FKM, FVMQ, other

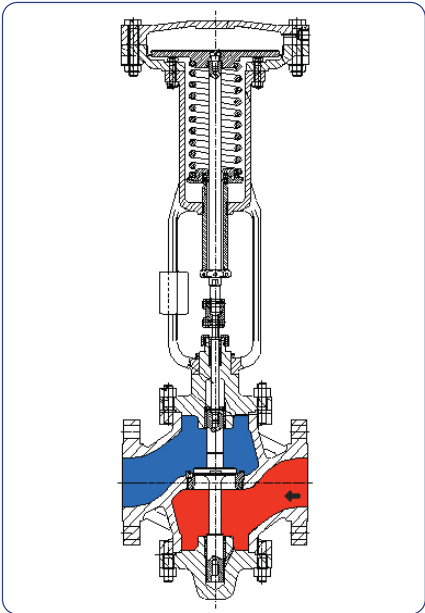

■ Inlet pressure

■ Outlet pressure

Index of tables and specifications

- Fluid applications • see table 1
- Capacities • see table 2
- Actuators operating range • see table 3
- Materials combination • see table 4
- Temperature Range • see tables 5 - 8
- Body weights • see tables 9
- Body weights • see tables 10
- Body Sizes and End Connections • see table 11 - 12
- Actuators dimension • see table 13

MM Series:
Flanged Connections Carbon Steel, Stainless Steel & Alloy Construction

The MM series are spring loaded, self actuated, direct-operated, valves. This series features both pressure reducing and pressure relief/backpressure valves. Pressure reducing valves are devices whose main function is to match the flow of the medium (gas, steam or liquid) through the regulator to the demand of the medium by the system. At the same time a regulator must maintain the system pressure at a requested value, or within an acceptable range of this pressure. Pressure relief valves are used to protect the system from over pressure. They can be used also as backpressure regulators as they have excellent throttling characteristics. They are available in 1 up to 10 inches (DN25 through DN250) body sizes. These regulators feature a construction capable of sustaining rugged use and their construction makes them easy to install and to maintain. The MM series is divided into 2 main groups:

- Downstream pressure regulating valves (pressure reducing valves):
 - a. Single seat (**MM81-83**)
 - b. Double seat (**MM71-73**)
- Upstream pressure regulating valves (backpressure valves):
 - a. Single seat (**MM82-84**)
 - b. Double seat (**MM72-74**)

General features:

- Flow to open design
- Available with ISA Face to face dimensions
- 3 different trim sizes for each body size, to meet a wide range of applications
- Quick-opening flow characteristics
- Trim features: Metal or Soft tightness, single or double ported
- Leakage Classes range from II up to VI (according to ANSI/FCI 70-3)
- External pressure sensing
- Stem tightness packing is available as elastomeric (lip seal) or graphite gasket
- Wide range of actuators according to the requested regulation range
- Wide range of elastomeric diaphragms

Special constructions:

- MM regulators are also available in special configurations:
- Exotic materials in short lead times (e.g. duplex, superduplex, alloy steel, monel, etc.)
 - Flow characteristics other than quick-opening
 - Stem packing made of PTFE coated gaskets
 - Body sizes up to DN 20"

Optionals e special configurations:

- Extended bonnet
- Hand wheel
- Double diaphragm
- Separation tank to handle superheated steam or high viscosity fluids
- Bolts and Nuts PTFE coated
- Butt weld and socket weld connections
- Pressure gauges

Tab. [1] - Fluid applications

Gas	Air, inert gas, CO ₂ , CO, hydrocarbons, O ₂ , H ₂ , F, NH ₃ .
Steam / Vapour	Water Steam, alcoholic vapours, organic vapours, sulphuric acid, refrigerating vapour.
Liquids	Water, aqueous solutions, hydrocarbons, alcohol, lubricating oils, diathermic, oils, solvents, refrigerating fluids, acrylic compounds.

Tab. [2a] - CV values | Single seated valves (MM81 MM82 MM83 MM84)

Trim size	Seat diameter (mm)	DN				
		25	40	50	80	100
1/2"	16,5	6				
3/4"	20,5	9	9			
1"	25	13	16	16		
1 1/2"	40		34	40	40	
2"	50			52	62	62
3"	70				110	128
4"	90					180

Tab. [2b] - CV values | Double seated valves (MM71 MM72 MM73 MM74)

Trim size	Seats diameter (mm)	DN							
		25	40	50	80	100	150	200	250
1/2"	16,5/14,5	6							
3/4"	20,5/18,5	9	9						
1"	25/23	13	18	18					
1 1/2"	40/38		40	43	43				
2"	50/48			54	64	64			
3"	70/68				112	128	128		
4"	90/88					204	240	240	
6"	135/132						430	440	440
8"	180/177							620	720
10"	225/222								850

Tab. [3] - Actuators operating range

Actuator	Actuators spring ranges							
	Min				Max		Maximum allowable pressure	
	Elastomeric packing (lip seal)		Graphite packing					
120	4,00 barg	(58,0 psig)	12,3 barg	(178 psig)	26,9 barg	(390 psig)	31 barg	(445 psig)
140	2,00 barg	(29,0 psig)	6,1 barg	(88 psig)	15,3 barg	(222 psig)	17 barg	(249 psig)
182	0,90 barg	(13,1 psig)	2,7 barg	(39 psig)	6,8 barg	(99 psig)	7,7 barg	(112 psig)
245	0,380 barg	(5,51 psig)	1,1 barg	(16 psig)	2,9 barg	(42,1 psig)	3,2 barg	(47,0 psig)
345	0,0045 barg	(0,07 psig)	0,47 barg	(6,8 psig)	1,2 barg	(17,4 psig)	1,8 barg	(26,5 psig)

NOTE:

Actuators spring ranges are based on the following assumptions:

- Stroke from setpoint is ± 7 mm
- Offset max 33% for minimum set pressure
- Low unbalancing forces on the plug
- Metal tightness, unless otherwise specified
- Seat leakage performance not taken into account for minimum set pressure evaluation

If different operating conditions are required please contact Carraro Technical Dept.

■ MM & BPM REGULATORS

Tab. [4] - Material Combinations

Body			
	Carbon steel (AF2)	316 SS (IF2)	Full 316 SS (IF3)
	-29°C ≤ T ≤ 427°C	-29°C ≤ T ≤ 540°C	-196°C ≤ T ≤ 540°C
	(-20°F ≤ T ≤ 800°F)	(-20°F ≤ T ≤ 1000°F)	(-321°F ≤ T ≤ 1000°F)
Body	ASME SA-216 WCC	ASME SA-351 CF8M	ASME SA-351 CF8M
Bonnet	ASME SA-216 WCC	ASME SA-351 CF8M	ASME SA-351 CF8M
Inferior Cover	ASME SA-216 WCC	ASME SA-351 CF8M	ASME SA-351 CF8M
Packing	See Tab.5		
Gaskets set	See Tab.6		
Trim			
Seat	ASME SA-479 316	ASME SA-479 316	ASME SA-479 316
Plug	ASME SA-479 316	ASME SA-479 316	ASME SA-479 316
Plug seating surface	See Tab.7		
Guide	ASTM A-564 17-4PH	ASTM A.276/A-479 UNS S21800	ASTM A.276/A-479 UNS S21800
Actuator			
Actuator cover	ASME SA-216 WCC	ASME SA-351 CF8M	ASME SA-351 CF8M
Yoke	ASME SA-216 WCC	ASME SA-216 WCC	ASME SA-351 CF8M
Spring	ASTM A 401	ASTM A 401	ASTM A-313 316
Diaphragm	See Tab.8		

NOTE:

- SS = Stainless steel
- Carbon steel parts are painted according to Carraro's internal procedures
- NACE material requirements: these material combinations meet the requirements of NACE MR 0103, non exposed conditions (par. 5.3).
- In case of exposed conditions (par. 5.2), or a different standard (e.g. NACE MR 0175-2003) please contact Carraro Technical Dept.

Tab. [5] - Temperature range for packing materials

Materials	Temperature limits
FKM Lip Seal	-10 to 200°C (14 to 392°F)
Graphite	-200 to 600°C (-328 to 1110°F)
PTFE coated aramid fiber	-200 to 260°C (-328 to 500°F)

Tab. [6] - Temperature range for flat gaskets

Materials	Temperature limits
Polytetrafluoroethylene (PTFE)	-200 to 250°C (-328 to 482°F)
No asbestos	-50 to 200°C (-58 to 392°F)
Graphite + AISI 316	-200 to 600°C (-328 to 1110°F)

Tab. [7] - Temperature range for plug seating surface

Materials	Temperature limits	Valve model
Stainless steel	-196 to 540°C (-321 to 1000°F)	BPM71 BPM72 BPM81 BPM82
Stellite 6	-150 to 600°C (-238 to 1110°F)	
Fluoroelastomer (FKM-FPM)	-10 to 200°C (-14 to 392°F)	BPM73 BPM74 BPM83 BPM84
Chloroprene (CR)	-20 to 90°C (-4 to 194°F)	
Nitrile (NBR)	-25 to 90°C (-13 to 194°F)	
Ethylene-Propylene (EPDM)	-35 to 150°C (-31 to 320°F)	
Silicone (VMQ)	-50 to 150°C (-58 to 300°F)	
Polytetrafluoroethylene (PTFE)	-200 to 250°C (-328 to 482°F)	BPM83 BPM84

Tab. [8] - Temperature range for diaphragms

Materials	Temperature limits
Chloroprene (CR)	-20 to 90°C (-4 to 194°F)
NBR	-25 to 90°C (-13 to 194°F)
Fluorocarbon (FKM-FPM) + polyester	-10 to 150°C (14 to 302°F)
Fluorocarbon (FKM-FPM) + polyaramid	-10 to 200°C (14 to 392°F)
Ethylene-Propylene (EPDM)	-35 to 150°C (-31 to 320°F)
Fluorosilicone (FVMQ)	-50 to 150°C (-58 to 300°F)

NOTE:

Diaphragm material is selected in order to withstand both temperature and chemical composition of the medium.

Tab. [9] - Body weights

Valve Model	DN	Connections									
		ANSI 150		ANSI 300		ANSI 600		ANSI 900		ANSI1500	
		PN10-16		PN25-40				PN160		PN250	
		kg	lbs	kg	lbs	kg	lbs	kg	lbs	kg	lbs
MM81 - MM82 (single seated)	25	14	31	15	33	16	34	33	73	33	73
	40	23	51	26	56	27	58	46	101	46	101
	50	29	64	31	68	33	73	65	143	65	143
	80	56	123	60	132	63	139	89	196	115	253
	100	74	163	78	172	96	211	89	196	115	253
MM71 - MM72 (double seated)	25	15	32	16	34	16	35	34	74	34	74
	40	27	59	30	65	31	67	50	110	50	110
	50	36	79	38	84	40	88	70	154	70	154
	80	66	145	70	154	73	161	106	233	134	295
	100	99	218	103	227	116	255	174	383	207	455
	150	168	370	182	400	224	493	//	//	//	//
	200	285	627	303	667	421	926	//	//	//	//
250	430	946	457	1005	671	1476	//	//	//	//	

Tab. [10] - Actuator weights

Actuator	kg	lbs
120	32	70
140	32	70
182	30	66
245	35	77
345	48	106

■ MM & BPM REGULATORS

Parts list:

- 1- Body cover
- 2- (a-b) Gaskets*
- 3- (a-b) Studs
- 4- (a-b) Stud nuts
- 5- Lower seat ring
- 6- Plug*
- 7- Valve body
- 8- Upper seat ring
- 9- Bonnet
- 10- Pin
- 11- Valve plug stem
- 12- Ring nut
- 13- Packing gland gaskets/lip seal*
- 14- Packing gland bushing
- 15- Packing gland nut
- 16- Joint
- 17- Yoke
- 18- Adjusting screw
- 19- Spring holder plate
- 20- Bearing
- 21- Actuator Stem
- 22- Balanced lug circlip
- 23- Spring
- 24- (a-b) Bolts
- 25- (a-b) Nuts
- 26- Lower diaphragm case
- 27- Upper diaphragm case
- 28- Diaphragm plate
- 29- Diaphragm*
- 30- Screw
- 31- Upper guide bushing
- 32- Lower guide bushing
- 33- Bearing spherical coupling
- 34- Bearing ring
- 35- Actuator guide bushing

* Recommended spare parts

2 years spare parts kit:

- flat gaskets (2 pcs)
- diaphragm
- Packing gland gasket/lip seal

5 years spare parts kit:

- flat gaskets (2 pcs)
- diaphragm
- Packing gland gasket/lip seal
- valve plug

MM71 72 section drawing

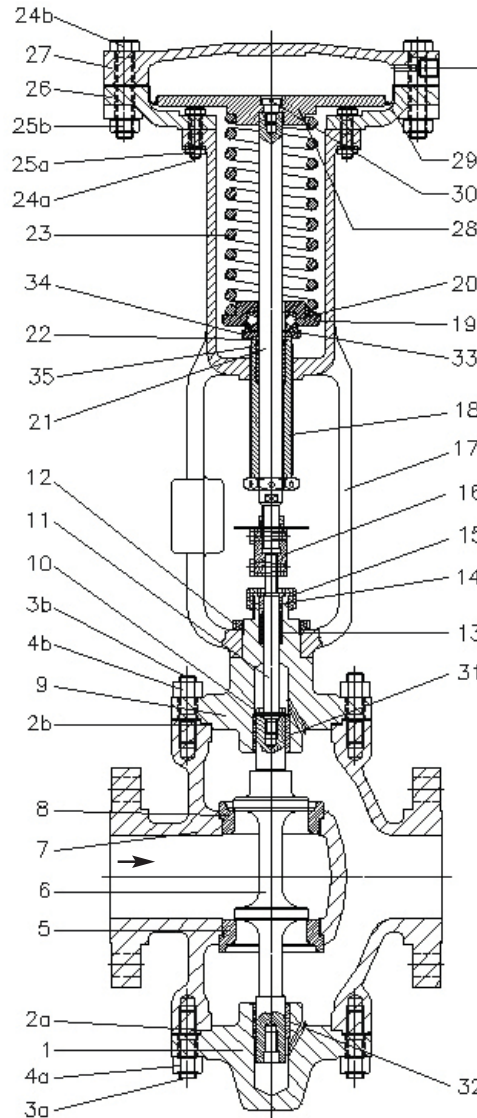

PRESSURE SENSING

Connect to:

- downstream pressure for MM71
- upstream pressure for MM72

MM71

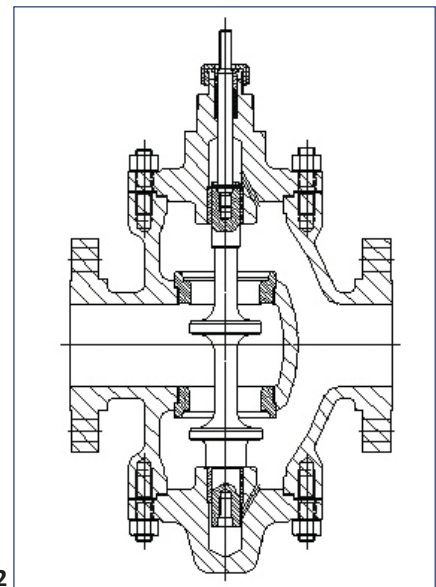

MM72

MM73 74 section drawing

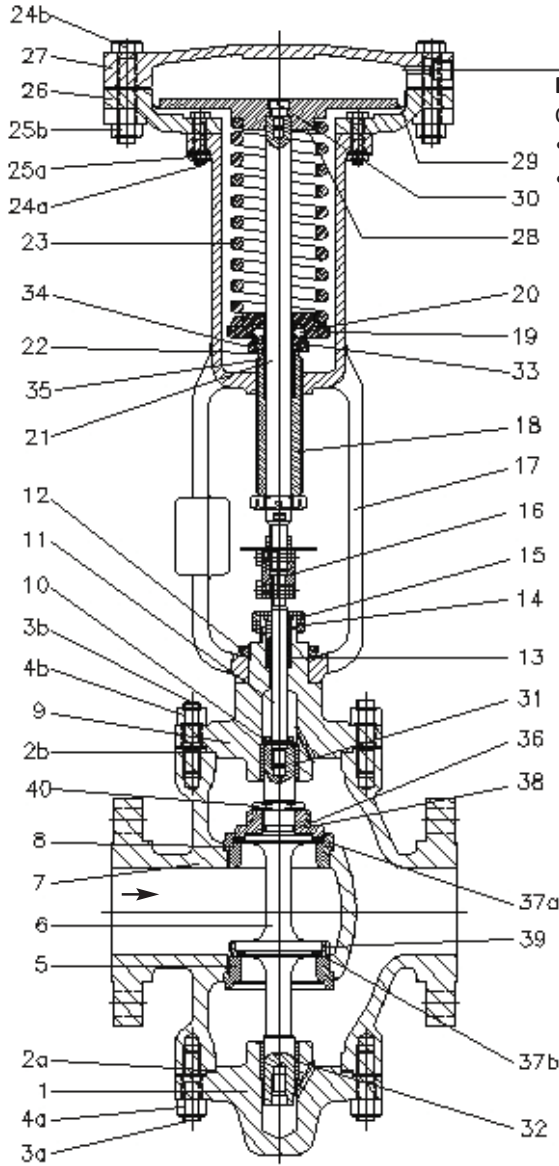

PRESSURE SENSING

Connect to:

- downstream pressure for MM73
- upstream pressure for MM74

MM73

Parts list:

- 1- Body cover
- 2- (a-b) Gaskets*
- 3- (a-b) Studs
- 4- (a-b) Stud nuts
- 5- Lower seat ring
- 6- Plug*
- 7- Valve body
- 8- Upper seat ring
- 9- Bonnet
- 10- Pin
- 11- Valve plug stem
- 12- Ring nut
- 13- Packing gland gaskets/lip seal*
- 14- Packing gland bushing
- 15- Packing gland nut
- 16- Joint
- 17- Yoke
- 18- Adjusting screw
- 19- Spring holder plate
- 20- Bearing
- 21- Actuator Stem
- 22- Balanced lug circlip
- 23- Spring
- 24- (a-b) Bolts
- 25- (a-b) Nuts
- 26- Lower diaphragm case
- 27- Upper diaphragm case
- 28- Diaphragm plate
- 29- Diaphragm*
- 30- Screw
- 31- Upper guide bushing
- 32- Lower guide bushing
- 33- Bearing spherical coupling
- 34- Bearing ring
- 35- Actuator guide bushing
- 36- O-Ring gasket*
- 37- Plug gaskets*
- 38- Adjustment nut
- 39- Lower nut
- 40- Nut

* Recommended spare parts

2 years spare parts kit:

- flat gaskets (2 pcs)
- diaphragm
- Packing gland gasket/lip seal

5 years spare parts kit:

- flat gaskets (2 pcs)
- diaphragm
- Packing gland gasket/lip seal
- valve plug

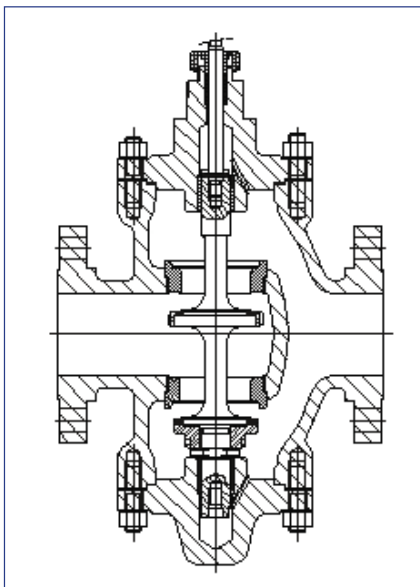

MM74

■ MM & BPM REGULATORS

Parts list:

- 1- Body cover
- 2- (a-b) Gaskets*
- 3- (a-b) Studs
- 4- (a-b) Stud nuts
- 5- Seat ring
- 6- Plug*
- 7- Valve body
- 8- Bonnet
- 9- Pin
- 10- Valve plug stem
- 11- Ring nut
- 12- Packing gland gaskets/lip seal*
- 13- Packing gland bushing
- 14- Packing gland nut
- 15- Joint
- 16- Yoke
- 17- Adjusting screw
- 18- Spring holder plate
- 19- Bearing
- 20- Actuator Stem
- 21- Balanced lug circlip
- 22- Spring
- 23- (a-b) Bolts
- 24- (a-b) Nuts
- 25- Lower diaphragm case
- 26- Upper diaphragm case
- 27- Diaphragm plate
- 28- Diaphragm*
- 29- Screw
- 30- Upper guide bushing
- 31- Lower guide bushing
- 32- Bearing spherical coupling
- 33- Bearing ring
- 34- Actuator guide bushing

* Recommended spare parts

2 years spare parts kit:

- flat gaskets (2 pcs)
- diaphragm
- Packing gland gasket/lip seal

5 years spare parts kit:

- flat gaskets (2 pcs)
- diaphragm
- Packing gland gasket/lip seal
- valve plug

MM81 82 section drawing

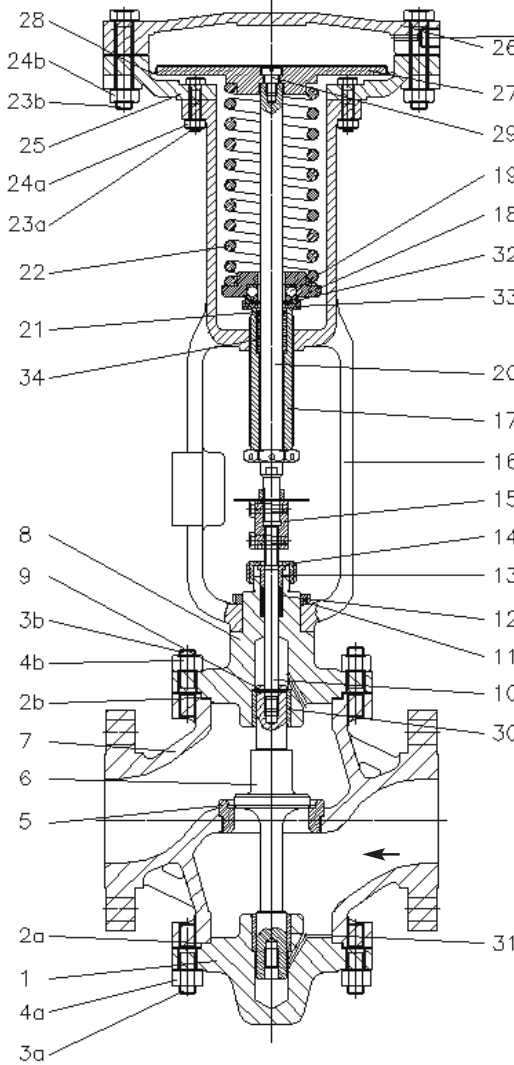

PRESSURE SENSING

Connect to:

- downstream pressure for MM81
- upstream pressure for MM82

MM81

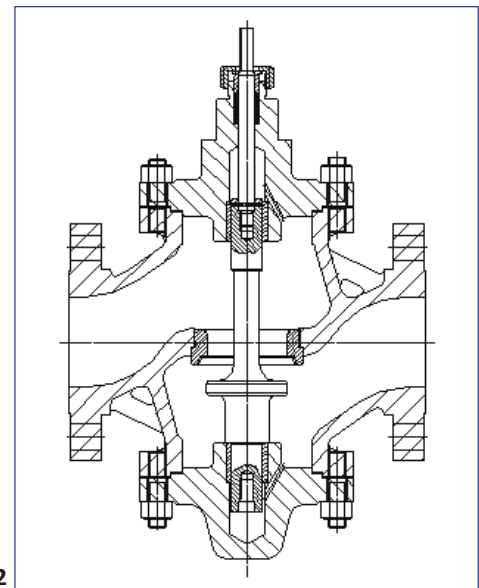

MM82

MM83 84 section drawing

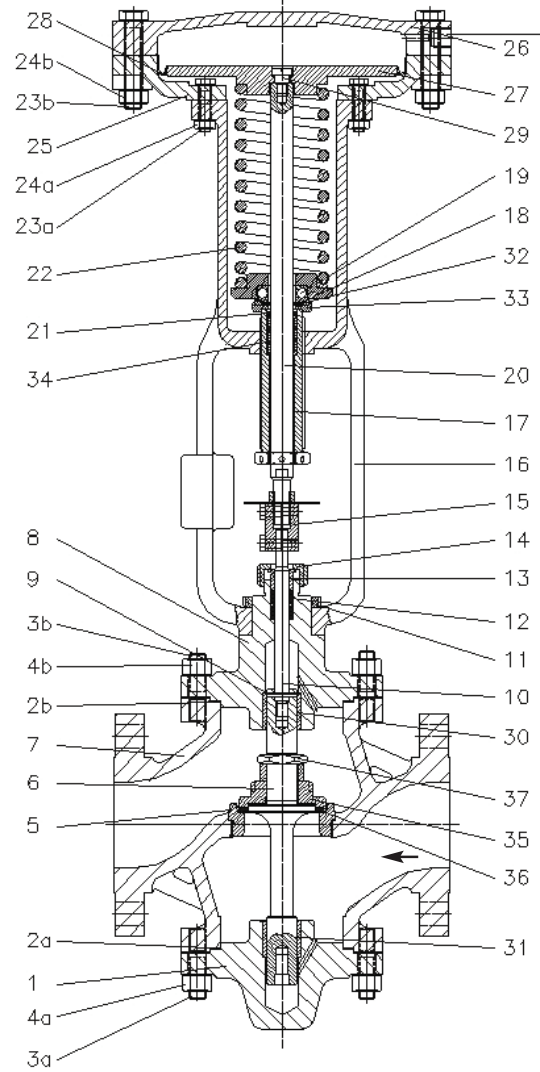

PRESSURE SENSING

Connect to:

- downstream pressure for MM83
- upstream pressure for MM84

MM83

Parts list:

- 1- Body cover
- 2- (a-b) Gaskets*
- 3- (a-b) Studs
- 4- (a-b) Stud nuts
- 5- Seat ring
- 6- Plug*
- 7- Valve body
- 8- Bonnet
- 9- Pin
- 10- Valve plug stem
- 11- Ring nut
- 12- Packing gland gaskets/lip seal*
- 13- Packing gland bushing
- 14- Packing gland nut
- 15- Joint
- 16- Yoke
- 17- Adjusting screw
- 18- Spring holder plate
- 19- Bearing
- 20- Actuator Stem
- 21- Balanced lug circlip
- 22- Spring
- 23- (a-b) Bolts
- 24- (a-b) Nuts
- 25- Lower diaphragm case
- 26- Upper diaphragm case
- 27- Diaphragm plate
- 28- Diaphragm*
- 29- Screw
- 30- Upper guide bushing
- 31- Lower guide bushing
- 32- Bearing spherical coupling
- 33- Bearing ring
- 34- Actuator guide bushing
- 35- Gasket*
- 36- Adjustment nut
- 37- Nut

* Recommended spare parts

2 years spare parts kit:

- flat gaskets (2 pcs)
- diaphragm
- Packing gland gasket/lip seal

5 years spare parts kit:

- flat gaskets (2 pcs)
- diaphragm
- Packing gland gasket/lip seal
- valve plug

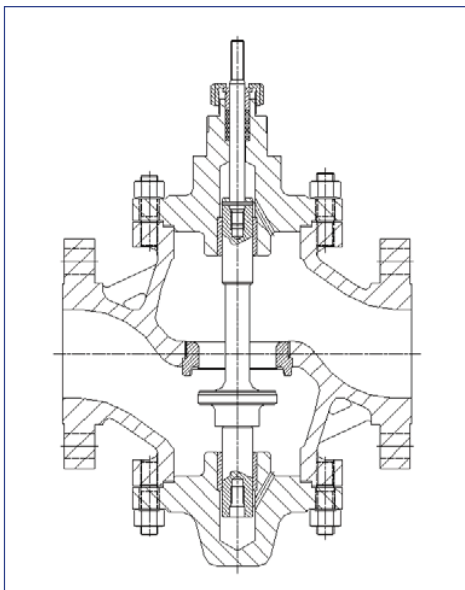

MM84

■ MM & BPM REGULATORS

MM flanged valve dimensional drawing

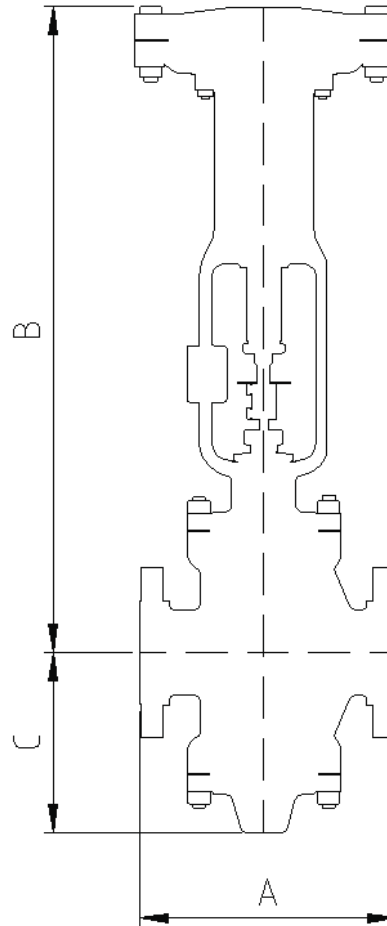

Tab. [11] -Body sizes and face-to-face dimensions. Double seated valves (MM71 72 73 74)

DN	A								
	ANSI B16.5 - RF					UNI - EN1092-1			
	150	300	600	900	1500	PN10-16	PN25-40	PN160	PN250
25	184	197	210	273		197		273	
40	222	235	251	311		235		311	
50	254	267	286	340		267		340	
80	298	318	337	387	406	318		387	406
100	352	368	394	464	483	352	368	464	483
150	451	473	508	//	//	451	473	//	//
200	543	568	610	//	//	543	568	//	//
250	673	708	752	//	//	673	708	//	//

DN	B		C		
	ANSI150-600	ANSI900-1500	ANSI150-600	ANSI900	ANSI1500
	PN10-40	PN160-250	PN10-40	PN160	PN250
25	737		122	140	
40	755		142	163	
50	765		166	180	
80	810	840	224	225	245
100	850	880	252	265	280
150	890	//	317	//	//
200	1010	//	407	//	//
250	1060	//	460	//	//

MM flanged valve dimensional drawing

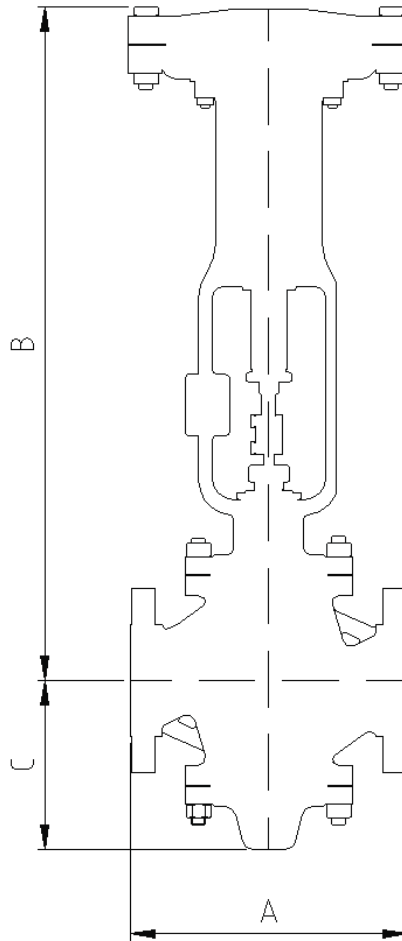

Tab. [12] -Body sizes and face-to-face dimensions. Single seated valves (MM81 82 83 84)

DN	A								
	ANSI B16.5 - RF					UNI - EN1092-1			
	150	300	600	900	1500	PN10-16	PN25-40	PN160	PN250
25	184	197	210	273		197		273	
40	222	235	251	311		235		311	
50	254	267	286	340		267		340	
80	298	318	337	387	406	318		387	406
100	352	368	394	464	483	352	368	464	483

DN	B		C		
	ANSI150-600	ANSI900-1500	ANSI150-600	ANSI900	ANSI1500
	PN10-40	PN160-250	PN10-40	PN160	PN250
25	717		102	120	
40	737		125	145	
50	745		146	160	
80	780	810	194	195	215
100	805	835	207	220	235

■ MM & BPM REGULATORS

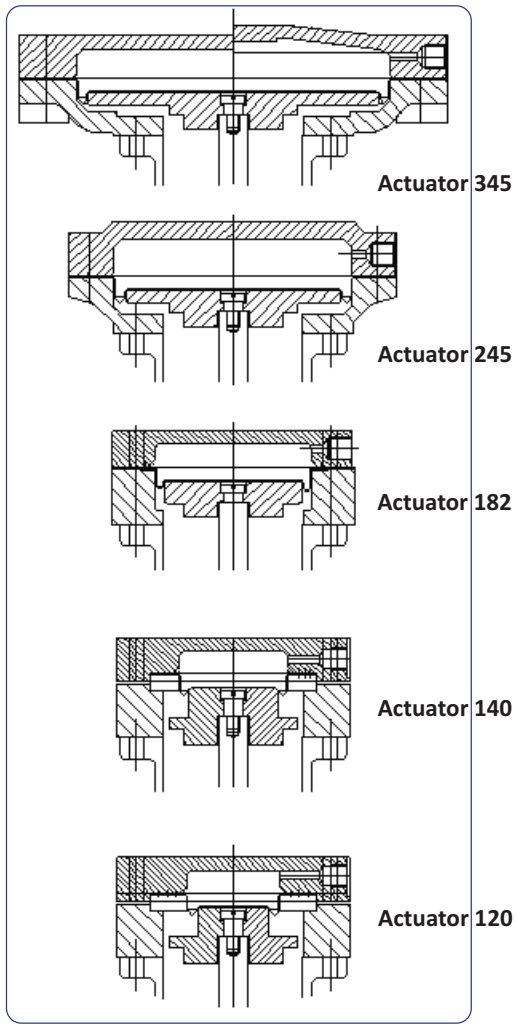

MM actuators:

The drawings show all our available actuators, which are perfectly interchangeable the one with the others according to the desired pressure regulation (please refer also to Tab. 3). The table below shows the actuators dimensions.

Tab. [13] - Actuators dimension

Actuator	Outer diameter		Surface	
	mm	inches	cm ²	in ²
120	175	6 7/8	20,8	3,22
140	175	6 7/8	42,4	6,57
182	182	7 1/4	95	14,7
245	245	9 5/8	226	35,0
345	345	13 5/8	545	84,5

MM ISA 3D PROJECT



Valve ID card

Function
Reducing - Relief / Backpressure

Seat type
Single/Double

Inlet / Outlet diameters
From 1" up to 10" (standard ISA constructions)
Up to 20" (special constructions)

Body material
Carbon steel, Stainless steel and Exotic materials

End connections
Flanged (ANSI or NP)

Max rating
ANSI 1500

CV
From 6 to 850

Trim materials
Stainless steel (std) and Exotic materials

Diaphragms
Polychloroprene, EPDM, FKM, FVMQ, other

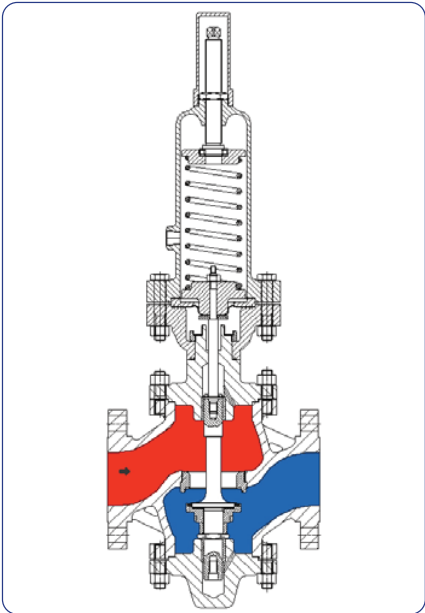

 Inlet pressure

 Outlet pressure

Index of tables and specifications

- Fluid applications • see table 1
- Capacities • see table 2
- Actuators operating range • see table 3
- Materials combination • see table 4
- Temperature Range • see tables 5 - 8
- Body weights • see tables 9
- Body weights • see tables 10
- Body Sizes and End Connections • see table 11 - 12
- Actuators dimension • see table 13

BPM Series:

Flanged Connections Carbon Steel, Stainless Steel & Alloy Construction

This series of regulators is derived from the series MM by changing the actuator assembly. BPM series features a packingless construction and closed spring case: those elements prevent any leakage from flowing outside the valve, both in normal operating and in case of diaphragm failure.

Moreover, the absence of packing increases the sensitivity of the valve since the friction is reduced to a minimum. A simple lip seal gasket is necessary for external pressure sensing construction. Finally, this series is more compact than MM and can be supplied either with internal or external pressure sensing.

The BPM series are spring loaded, self actuated, direct-operated, valves.

This series features both pressure reducing and pressure relief/backpressure valves. Pressure reducing valves are devices whose main function is to match the flow of the medium (gas, steam or liquid) through the regulator to the demand of the medium by the system. At the same time a regulator must maintain the system pressure at a requested value, or within an acceptable range of this pressure. Pressure relief valve are used to protect the system from over pressure. They can be used also as backpressure regulators as they have excellent throttling characteristics. They are available in 1 up to 10 inches (DN25 through DN250) body sizes. These regulators feature a construction capable of sustaining rugged use and their construction makes them easy to install and to maintain.

The BPM series is divided into 2 main groups:

- Downstream pressure regulating valves (pressure reducing valves):
 - a. Single seat (**BPM81-83**)
 - b. Double seat (**BPM71-73**)
- Upstream pressure regulating valves (backpressure valves):
 - a. Single seat (**BPM82-84**)
 - b. Double seat (**BPM72-74**)

General features:

- Available with ISA Face to face dimensions
- 3 different trim sizes for each body size, to meet a wide range of applications
- Quick-opening flow characteristics
- Trim features: Metal or Soft tightness, single or double ported
- Leakage Classes range from II up to VI (according to ANSI/FCI 70-3)
- Internal pressure sensing
- Wide range of actuators according to the requested regulation range
- Wide range of elastomeric diaphragms

Special constructions:

BPM regulators are also available in special configurations:

- Exotic materials in short lead times (e.g. duplex, superduplex, alloy steel, monel, etc.)
- Flow characteristics other than quick-opening
- Body sizes up to DN 20"

Optionals e special configurations:

- Hand wheel
- Double diaphragm
- Separation tank to handle or high viscosity fluids
- Bolts and Nuts PTFE coated
- Butt weld and socket weld connections
- External pressure sensing
- Pressure gauges

Tab. [1] - Fluid applications

Gas	Air, inert gas, CO ₂ , CO, hydrocarbons, O ₂ , H ₂ , F, NH ₃ .
Steam / Vapour	Water Steam, alcoholic vapours, organic vapours, sulphuric acid, refrigerating vapour.
Liquid	Water, aqueous solutions, hydrocarbons, alcohol, lubricating oils, diathermic, oils, solvents, refrigerating fluids, acrylic compounds.

Tab. [2a] - CV values | Single seated valves (BPM81 BPM82 BPM83 BPM84)

Trim size	Seat diameter (mm)	DN				
		25	40	50	80	100
1/2"	16,5	6				
3/4"	20,5	9	9			
1"	25	13	16	16		
1 1/2"	40		34	40	40	
2"	50			52	62	62
3"	70				110	128
4"	90					180

Tab. [2b] - CV values | Double seated valves (BPM71 BPM72 BPM73 BPM74)

Trim size	Seats diameter (mm)	DN							
		25	40	50	80	100	150	200	250
1/2"	16,5/14,5	6							
3/4"	20,5/18,5	9	9						
1"	25/23	13	18	18					
1 1/2"	40/38		40	43	43				
2"	50/48			54	64	64			
3"	70/68				112	128	128		
4"	90/88					204	240	240	
6"	135/132						430	440	440
8"	180/177							620	720
10"	225/222								850

NOTE:

CV values for pressure rating **Class 1500** could be slightly inferior than the values shown above. For details please contact Carraro Technical Dept.

Tab. [3] - Actuators operating ranges

Actuator	Actuators spring ranges				Maximum allowable pressure	
	min		max			
120	4,00 barg	(58,0 psig)	26,9 barg	(390 psig)	31 barg	(445 psig)
140	2,00 barg	(29,0 psig)	15,3 barg	(222 psig)	17 barg	(249 psig)
182	0,90 barg	(13,1 psig)	6,8 barg	(99 psig)	7,7 barg	(112 psig)
245	0,380 barg	(5,51 psig)	2,9 barg	(42,1 psig)	3,2 barg	(47,0 psig)
345	0,0045 barg *	(0,07 psig)	1,2 barg	(17,4 psig)	1,3 barg	(19,4 psig)
515	0,0015 barg *	(0,02 psig)	0,48 barg	(7,0 psig)	0,5 barg	(7,3 psig)

NOTE:

Actuators spring ranges are based on the following assumptions:

- Stroke from setpoint is ± 7 mm
- Offset max 33% for minimum set pressure
- Low unbalancing forces on the plug
- Metal tightness, unless otherwise specified

If different operating conditions are required please contact Carraro Technical Dept.

■ MM & BPM REGULATORS

Tab. [4] - Material Combination

Body			
	Carbon steel (AF2)	316 SS (IF2)	Full 316 SS (IF3)
	-29°C ≤ T ≤ 200°C	-29°C ≤ T ≤ 200°C	-50°C ≤ T ≤ 200°C
	(-20°F ≤ T ≤ 392°F)	(-20°F ≤ T ≤ 392°F)	(-58°F ≤ T ≤ 392°F)
Body	ASME SA-216 WCC	ASME SA-351 CF8M	ASME SA-351 CF8M
Bonnet	ASME SA-216 WCC	ASME SA-351 CF8M	ASME SA-351 CF8M
Inferior Cover	ASME SA-216 WCC	ASME SA-351 CF8M	ASME SA-351 CF8M
Packing	See Tab.6		
Gaskets set	See Tab.7		
Trim			
Seat	ASME SA-479 316	ASME SA-479 316	ASME SA-479 316
Plug	ASME SA-479 316	ASME SA-479 316	ASME SA-479 316
Plug seating surface	See Tab.8		
Guide	ASTM A-564 17-4PH	ASTM A.276/A-479 UNS S21800	ASTM A.276/A-479 UNS S21800
Actuator			
Actuator spring case	ASME SA-216 WCC	ASME SA-351 CF8M	ASME SA-351 CF8M
Actuator lower flange	ASME SA-216 WCC	ASME SA-216 WCC	ASME SA-351 CF8M
Spring	ASTM A 401	ASTM A 401	ASTM A-313 316
Diaphragm	See Tab.9		

NOTE:

- SS = Stainless steel
- Carbon steel parts are painted according to Carraro's internal procedures
- NACE material requirements: these material combinations meet the requirements of NACE MR 0103, non exposed conditions (par. 5.3). In case of exposed conditions (par. 5.2), or a different standard (e.g. NACE MR 0175-2003) please contact Carraro Technical Dept.

Tab. [5] - Temperature range for packing materials

Materials	Temperature limits
FKM Lip Seal	-10 to 200°C (14 to 392°F)

Tab. [6] - Temperature range for flat gaskets

Materials	Temperature limits
Polytetrafluoroethylene (PTFE)	-200 to 250°C (-328 to 482°F)
No asbestos	-50 to 200°C (-58 to 392°F)
Graphite + AISI 316	-200 to 600°C (-328 to 1110°F)

Tab. [7] - Temperature range for plug seating surface

Materials	Temperature limits	Valve model
Stainless steel	-196 to 540°C (-321 to 1000°F)	BPM71 BPM72 BPM81 BPM82
Stellite 6	-150 to 600°C (-238 to 1110°F)	
Fluoroelastomer (FKM-FPM)	-10 to 200°C (-14 to 392°F)	BPM73 BPM74 BPM83 BPM84
Chloroprene (CR)	-20 to 90°C (-4 to 194°F)	
Nitrile (NBR)	-25 to 90°C (-13 to 194°F)	
Ethylene-Propylene (EPDM)	-35 to 150°C (-31 to 320°F)	
Silicone (VMQ)	-50 to 150°C (-58 to 300°F)	
Polytetrafluoroethylene (PTFE)	-200 to 250°C (-328 to 482°F)	BPM83 BPM84

Tab. [8] - Temperature range for diaphragms

Materials	Temperature limits
Chloroprene (CR)	-20 to 90°C (-4 to 194°F)
NBR	-25 to 90°C (-13 to 194°F)
Fluorocarbon (FKM-FPM) + polyester	-10 to 150°C (14 to 302°F)
Fluorocarbon (FKM-FPM) + polyaramid	-10 to 200°C (14 to 392°F)
Ethylene-Propylene (EPDM)	-35 to 150°C (-31 to 320°F)
Fluorosilicone (FVMQ)	-50 to 150°C (-58 to 300°F)

NOTE:

Diaphragm material is selected in order to withstand both temperature and chemical composition of the medium.

Tab. [9] - Body weights

Valve Model	DN	Connections									
		ANSI 150		ANSI 300		ANSI 600		ANSI 900		ANSI 1500	
		PN10-16		PN25-40				PN160		PN250	
		kg	lbs	kg	lbs	kg	lbs	kg	lbs	kg	lbs
BPM81 BPM82 BPM83 BPM84 (single seated)	25	14	31	15	33	16	34	33	73	33	73
	40	23	51	26	56	27	58	46	101	46	101
	50	29	64	31	68	33	73	65	143	65	143
	80	56	123	60	132	63	139	89	196	115	253
	100	74	163	78	172	96	211	89	196	115	253
BPM71 BPM72 BPM73 BPM74 (double seated)	25	15	32	16	34	16	35	34	74	34	74
	40	27	59	30	65	31	67	50	110	50	110
	50	36	79	38	84	40	88	70	154	70	154
	80	66	145	70	154	73	161	106	233	134	295
	100	99	218	103	227	116	255	174	383	207	455
	150	168	370	182	400	224	493		0		0
	200	285	627	303	667	421	926		0		0
250	430	946	457	1005	671	1476		0		0	

Tab. [10] - Actuator weights

Actuator	kg	lbs
120	30	66
140	30	66
182	24	53
245	32	70
345	42	92
515	33	73

■ MM & BPM REGULATORS

Parts list:

- 1- Body cover
- 2- (a-b) Gasket (*)
- 3- (a-b) Screw
- 4- (a-b) Nuts
- 5- Lower seat
- 6- Plug (*)
- 7- Body valve
- 8- Upper seat
- 9- Packing gland cover
- 10- Pin
- 11- Stem
- 12- Upper guide bush
- 13- Lower guide bush
- 14- Nut
- 15- Lower flange
- 16- Diaphragm lower washer
- 17- Diaphragm upper washer
- 18- Diaphragm O-ring (*)
- 19- Diaphragm plate
- 20- Diaphragm (*)
- 21- Actuator ring
- 22- Screw
- 23- Nut
- 24- Nut
- 25- Spring
- 26- Upper spring loader plate
- 27- Axial bearing
- 28- Adjustment screw
- 29- Cap gasket (*)
- 30- Adjustment screw nut
- 31- Cap
- 32- Spring case
- 33- Gasket (*)
- 38- Gasket (*)

* Recommended spare parts

2 years spare parts kit:

- flat gaskets (2 pcs)
- diaphragm

5 years spare parts kit:

- flat gaskets (2 pcs)
- diaphragm
- valve plug

BPM71 72 section drawing

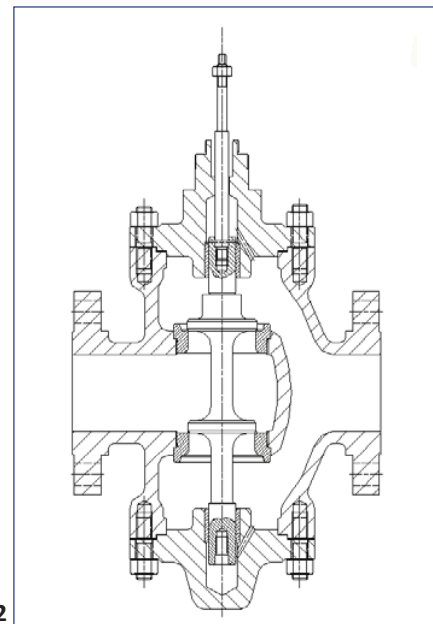
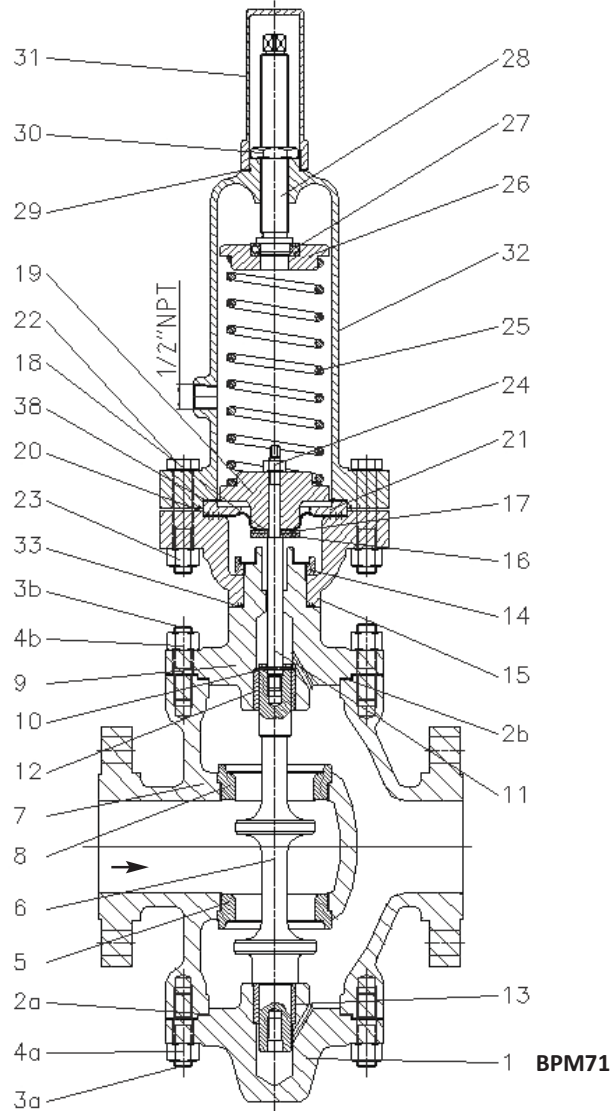

BPM73 74 section drawing

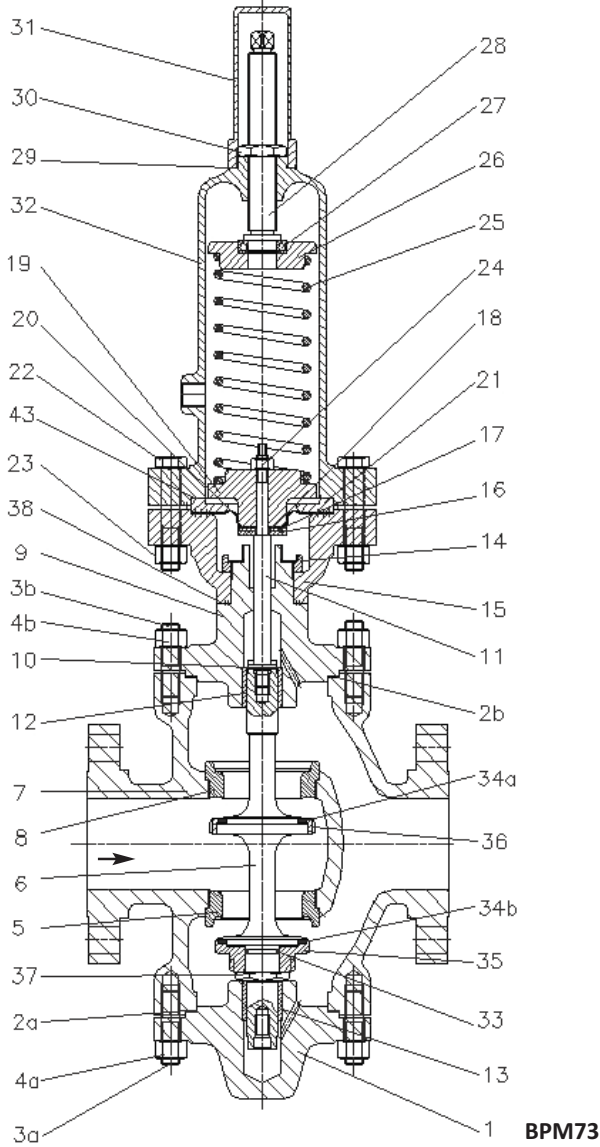

Parts list:

- 1- Body cover
- 2- (a-b) Gasket (*)
- 3- (a-b) Screw
- 4- (a-b) Nuts
- 5- Lower seat
- 6- Plug (*)
- 7- Body valve
- 8- Upper seat
- 9- Packing gland cover
- 10- Pin
- 11- Stem
- 12- Upper guide bush
- 13- Lower guide bush
- 14- Nut
- 15- Lower flange
- 16- Diaphragm lower washer
- 17- Diaphragm upper washer
- 18- Diaphragm O-ring (*)
- 19- Diaphragm plate
- 20- Diaphragm (*)
- 21- Actuator ring
- 22- Screw
- 23- Nut
- 24- Nut
- 25- Spring
- 26- Upper spring loader plate
- 27- Axial bearing
- 28- Adjustment screw
- 29- Cap gasket (*)
- 30- Adjustment screw nut
- 31- Cap
- 32- Spring case
- 33- O-ring gasket (*)
- 34- Plug gasket (*)
- 35- Adjustment nut
- 36- Lower nut
- 37- Nut
- 38- Gasket (*)
- 43- Gasket (*)

(*) recommended spare part

2 years spare parts kit:

- flat gaskets (2 pcs)
- diaphragm

5 years spare parts kit:

- flat gaskets (2 pcs)
- diaphragm
- valve plug

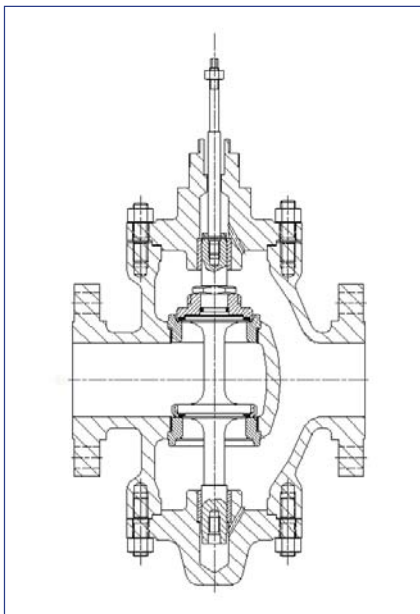

■ MM & BPM REGULATORS

Parts list:

- 1- Body cover
- 2- (a-b) Gasket (*)
- 3- (a-b) Screw
- 4- (a-b) Nuts
- 5- Seat
- 6- Plug (*)
- 7- Body valve
- 8- Packing gland cover
- 9- Pin
- 10- Stem
- 11- Upper guide bush
- 12- Lower guide bush
- 13- Nut
- 14- Lower flange
- 15- Diaphragm lower washer
- 16- Diaphragm upper washer
- 17- Diaphragm O-ring (*)
- 18- Diaphragm plate
- 19- Diaphragm
- 20- Actuator ring
- 21- Screw
- 22- Nut
- 23- Nut
- 24- Spring
- 25- Upper spring loader plate
- 26- Axial bearing
- 27- Adjustment screw
- 28- Cap gasket (*)
- 29- Adjustment screw nut
- 30- Cap
- 31- Spring case
- 32- Gasket (*)
- 37- Gasket (*)

(*) Recommended spare parts

2 years spare parts kit:

- flat gaskets (2 pcs)
- diaphragm

5 years spare parts kit:

- flat gaskets (2 pcs)
- diaphragm
- valve plug

BPM81 82 section drawing

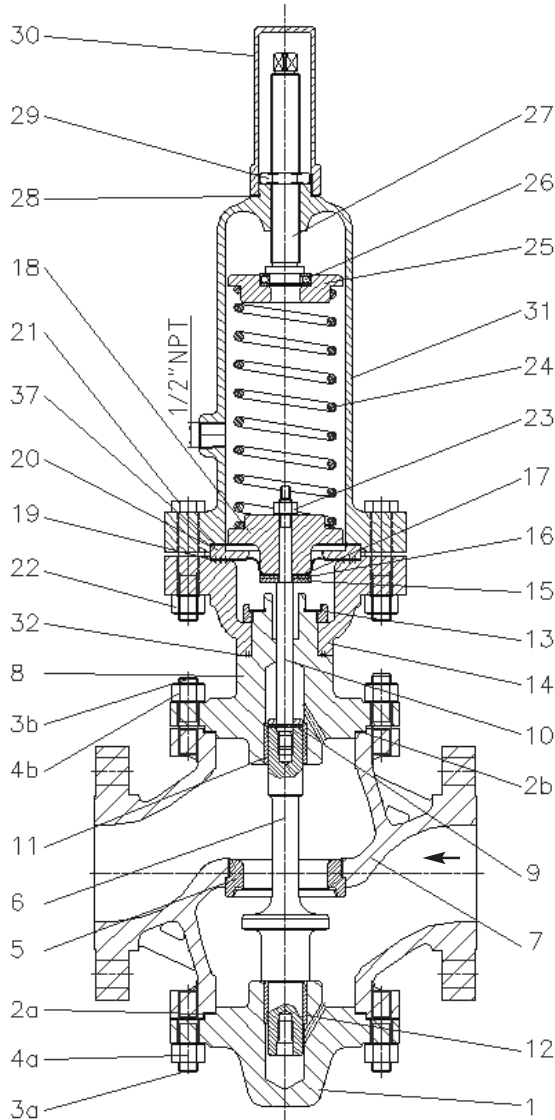

BPM81

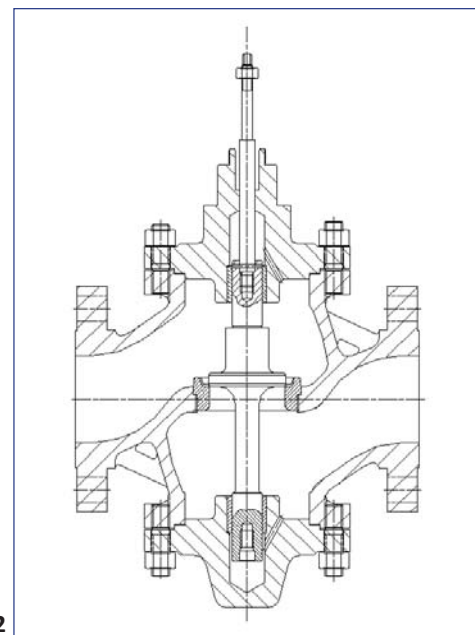

BPM82

BPM83 84 section drawing

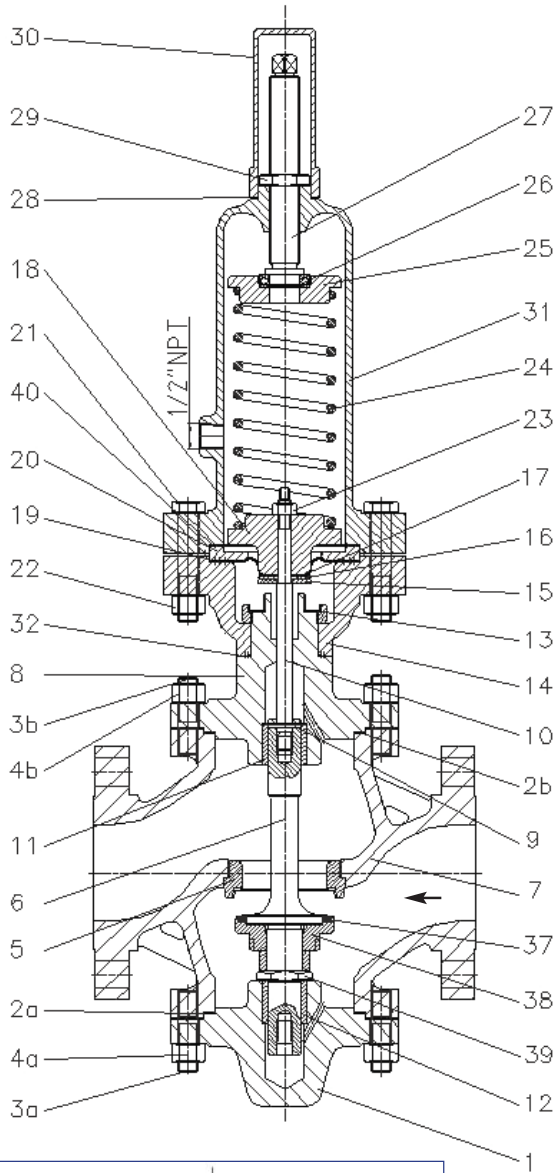

BPM83

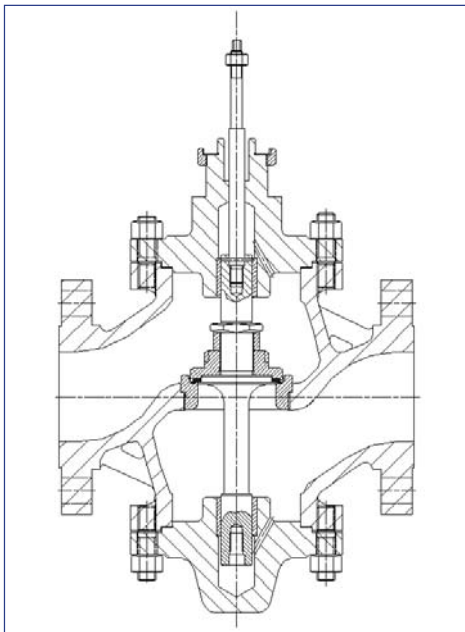

BPM84

Parts list:

- 1- Body cover
- 2- (a-b) Gasket (*)
- 3- (a-b) Screw
- 4- (a-b) Nuts
- 5- Seat
- 6- Plug (*)
- 7- Body valve
- 8- Packing gland cover
- 9- Pin
- 10- Stem
- 11- Upper guide bush
- 12- Lower guide bush
- 13- Nut
- 14- Lower flange
- 15- Diaphragm lower washer
- 16- Diaphragm upper washer
- 17- Diaphragm O-ring (*)
- 18- Diaphragm plate
- 19- Diaphragm
- 20- Actuator ring
- 21- Screw
- 22- Nut
- 23- Nut
- 24- Spring
- 25- Upper spring loader plate
- 26- Axial bearing
- 27- Adjustment screw
- 28- Cap gasket (*)
- 29- Adjustment screw nut
- 30- Cap
- 31- Spring case
- 32- Gasket (*)
- 37- Plug gasket
- 38- Adjustment nut
- 39- Nut
- 40- Gasket (*)

(*) Recommended spare parts

2 years spare parts kit:

- flat gaskets (2 pcs)
- diaphragm

5 years spare parts kit:

- flat gaskets (2 pcs)
- diaphragm
- valve plug

■ MM & BPM REGULATORS

BPM flanged valve dimensional drawing

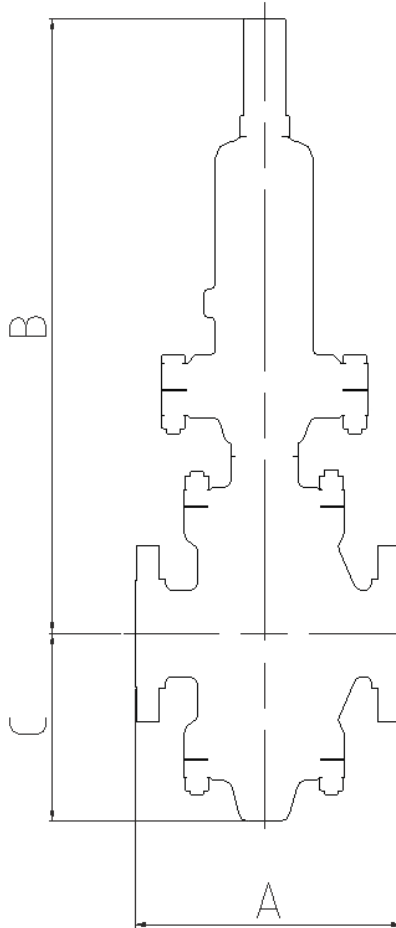

Tab. [11] - Body sizes and face-to-face dimensions. Double seated valves (BPM71 BPM72 BPM73 BPM74)

DN	A								
	ANSI B16.5 - RF				UNI - EN1092-1				
	150	300	600	900	1500	PN10-16	PN25-40	PN160	PN250
25	184	197	210	273		197		273	
40	222	235	251	311		235		311	
50	254	267	286	340		267		340	
80	298	318	337	387	406	318		387	406
100	352	368	394	464	483	352	368	464	483
150	451	473	508			451	473		
200	543	568	610			543	568		
250	673	708	752			673	708		

DN	B		C		
	ANSI150-600	ANSI900-1500	ANSI150-600	ANSI900	ANSI1500
	PN10-40	PN160-250	PN10-40	PN160	PN250
25	672		122	140	
40	690		142	163	
50	700		166	180	
80	745	775	224	225	245
100	785	815	252	265	280
150	825		317		
200	945		407		
250	995		460		

BPM flanged valve dimensional drawing

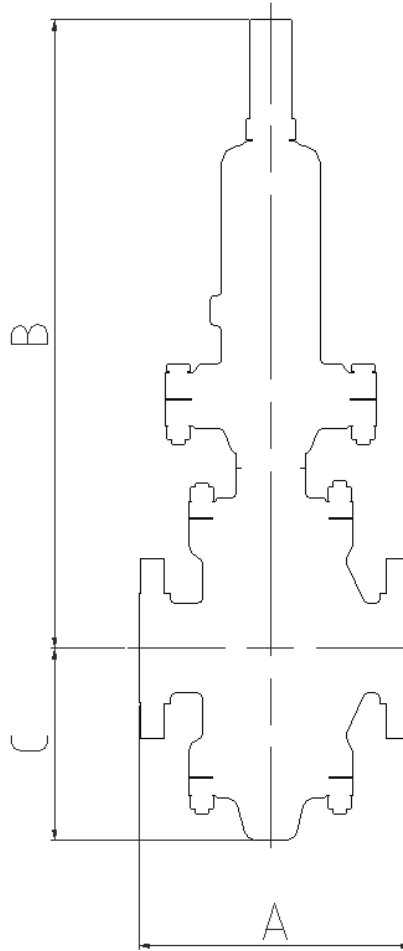

Tab. [12] - Body sizes and face-to-face dimensions. Single seated valves (BPM81 BPM82 BPM83 BPM84)

DN	A								
	ANSI B16.5 - RF					UNI - EN1092-1			
	150	300	600	900	1500	PN10-16	PN25-40	PN160	PN250
25	184	197	210	273		197		273	
40	222	235	251	311		235		311	
50	254	267	286	340		267		340	
80	298	318	337	387	406	318		387	406
100	352	368	394	464	483	352	368	464	483

DN	B		C		
	ANSI150-600	ANSI900-1500	ANSI150-600	ANSI900	ANSI1500
	PN10-40	PN160-250	PN10-40	PN160	PN250
25	652		102	120	
40	672		125	145	
50	680		146	160	
80	715	745	194	195	215
100	740	770	207	220	235

■ MM & BPM REGULATORS

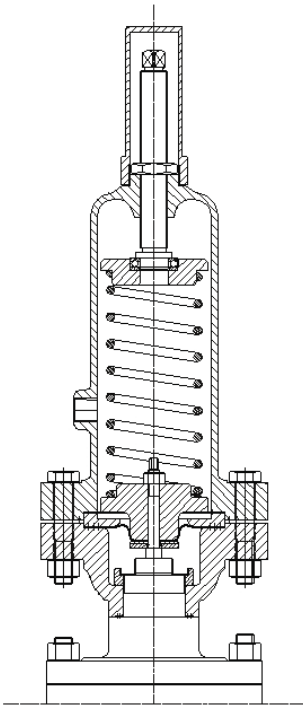

Serv.120

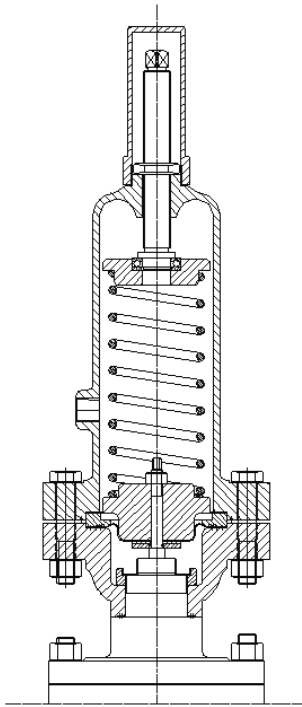

Serv.140

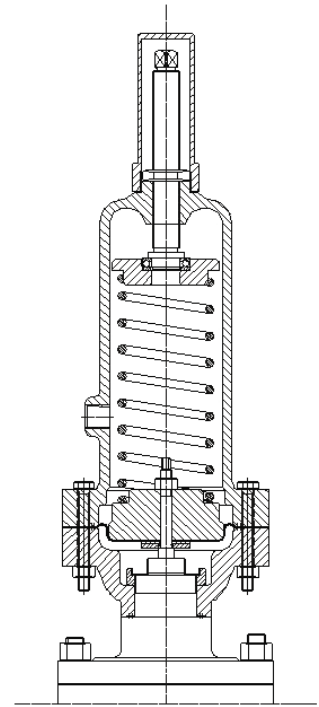

Serv.182

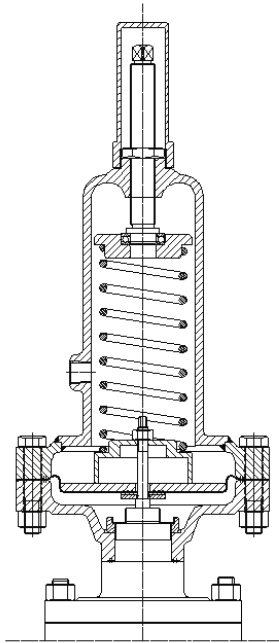

Serv.245

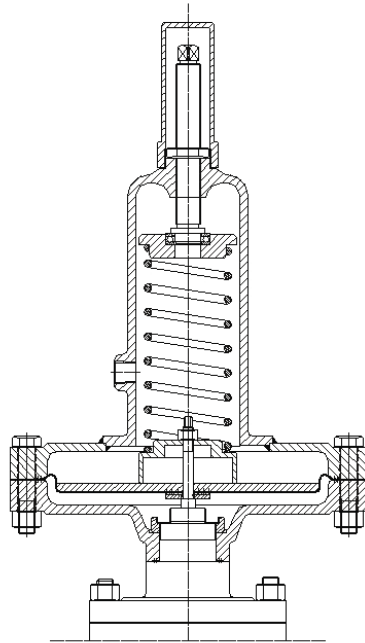

Serv.345

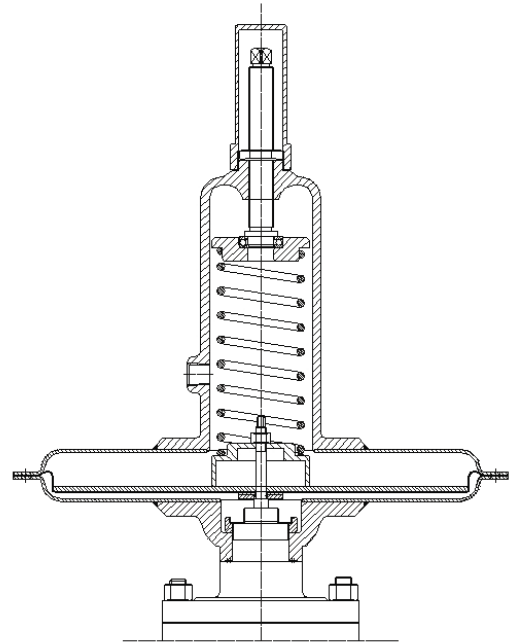

Serv.515

BPM actuators:

The drawings show all our available actuators, which are perfectly interchangeable the one with the others according to the desired pressure regulation (please refer also to Tab. 3). The table below shows the actuators dimensions.

Actuator	Outlet diameter		Surface	
	mm	inches	cm ²	in ²
120	175	6,9	20,8	3,22
140	175	6,9	42,4	6,57
182	182	7,3	95	14,7
245	245	9,6	226	35,0
345	345	13,6	545	84,5
515	515	20,3	1350	209,3

BPM ISA 3D PROJECT

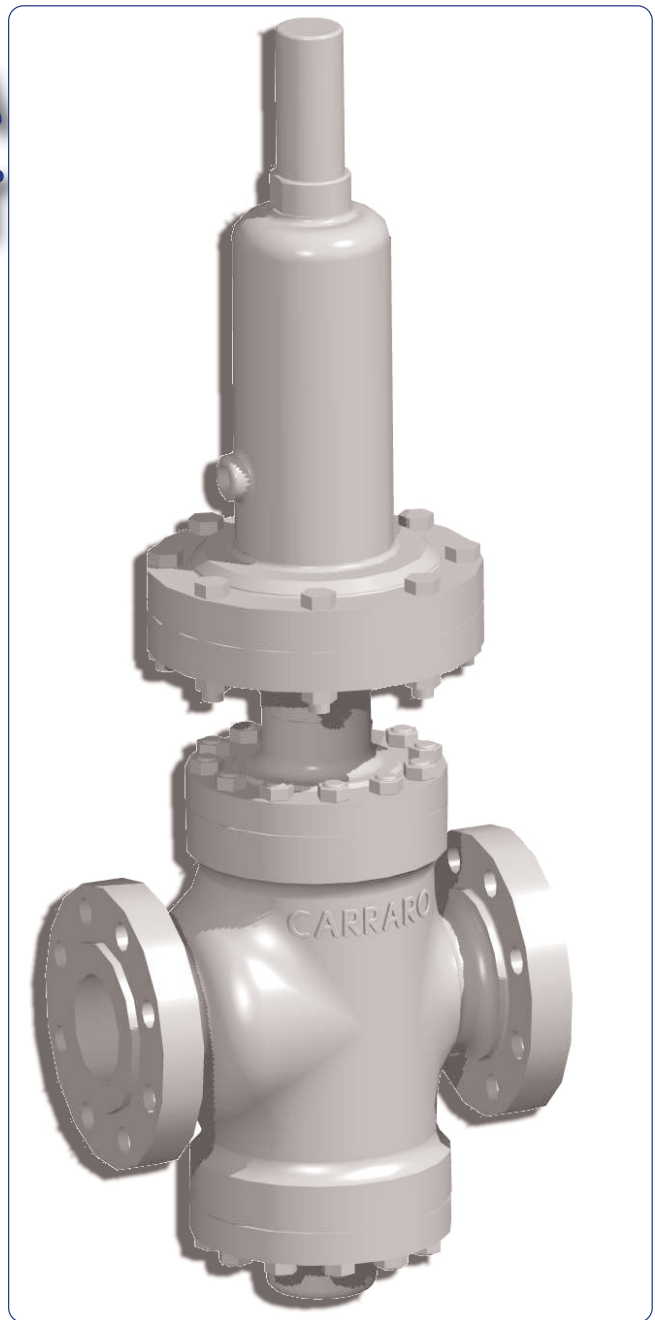

Distributed by | Distribuido por :



ANYTHING
≈ FLOWS ≈

INFO@ANYTHINGFLOWS.COM

WWW.ANYTHINGFLOWS.COM

Flow Control , our passion ®

Life Flows on ™



SCAN ME